

## Electronics and Data Acquisition System In the HiRes Prototype

D.J. Bird,<sup>1</sup> J. Boyer,<sup>2</sup> R.W. Clay,<sup>3</sup> S.C. Corbato,<sup>4</sup> H.Y. Dai,<sup>4</sup> B.R. Dawson,<sup>3</sup> R.W. Downing,<sup>1</sup> J.W. Elbert,<sup>4</sup> M.H.A. Huang,<sup>4</sup> M.J. Kidd,<sup>1</sup> D.B. Kieda,<sup>4</sup> S. Ko,<sup>4</sup> C.G. Larsen,<sup>4</sup> W. Lee,<sup>2</sup> E.C. Loh,<sup>4</sup> E. Mannel,<sup>2</sup> T.A. O'Halloran,<sup>1</sup> M.H. Salamon,<sup>4</sup> J.D. Smith,<sup>4</sup> P. Sokolsky,<sup>4</sup> P. Sommers,<sup>4</sup> J.K.K. Tang<sup>4</sup> and S.B. Thomas<sup>4</sup>

<sup>1</sup> Department of Physics, University of Illinois at Urbana-Champaign, Urbana, IL 61801  
USA

<sup>2</sup> Nevis Laboratories, Columbia University, Irvington NY 10533  
USA

<sup>3</sup> Department of Physics and Mathematical Physics, University of Adelaide, Adelaide, South Australia 5001  
Australia

<sup>4</sup> High Energy Astrophysics Institute, Department of Physics, University of Utah, Salt Lake City UT 84112  
USA

### 1. INTRODUCTION

The Hires Prototype is the second generation Fly's Eye type detector built for the observation of the atmospheric showers produced by ultra high energy cosmic rays ( Bird et al, 1993 ). It is being operated with 14 detector clusters. Each cluster consists of 256 individually analyzed photomultiplier tubes ( PMT ). The 256 PMTs are divided into 16 groups called subclusters. Each subcluster forms a 4x4 block of adjacent PMTs. The task of the electronics and data acquisition system is to filter out the night sky background light, identify the extensive air shower nitrogen fluorescence track, and measure the intensity and timing of each PMT which observes a shower track. The minimum dynamic range and the accuracy of the time and charge measurement are constrained by the desired detector aperture and energy sensitivity range. The system must also be able to process the data and background triggering rates without incurring excessive dead time. These requirements have been met in the Hires prototype by our data acquisition system as described in this paper.

### 2.OVERVIEW

The data acquisition for the Hires prototype is illustrated in figure 1. The mirror crates are located in the remote mirror houses, one for each mirror cluster. Each mirror ( VME ) crate contains all the electronics necessary for measuring the PMT wave form characteristics and recognizing the event trigger. There is a 68030 based crate controller, 16 data acquisition boards ( called ommatidial boards ), a trigger board, a sensor/relay board and a programmable pulse generator board. All the boards except the controller are designed and built by our engineers.

A RISC-based workstation serves as the central control. It communicates with the controller in a "central timing crate" and the controllers in 14 "mirror crates". All communication takes places through a single Ethernet line.

The central timing crate employs a 68030-based VME CPU as the crate controller. It receives and latches the absolute WWVB time and the relative 25nS scaler time of every mirror holdoff signal for every mirror event trigger. It also broadcasts a WWVB minute signal and a WWVB millisecond signal to all of the mirror crates. The mirror crates use these signals to latch the number of minutes into the data taking session and the number of milliseconds in to the minute each event occurs. These time values are used for matching the mirror event data from multiple mirror events.

### 3. MIRROR CRATE ELECTRONICS

Amplified signals from 16 photomultiplier tubes ( PMTs ) of a subcluster are sent to each of the sixteen ommatidial boards that instrument one mirror's PMT cluster. Each ommatidial board consists of an analog and a digital section. The analog section has input buffers, PMT trigger, PMT charge integration and trigger time circuits. The digital section is controlled by an Intel 80188 microcontroller and performs PMT trigger rate monitoring, trigger threshold adjusting, subcluster trigger generation and PMT charge and time digitization. Figure 2 ( fig 4.12 of proposal ) illustrates the functional operation of this board.

Each buffered input signal is passed through one of two microcontroller selected low-pass filters with time constants of 100nS and 375nS for night sky background noise suppression. The signal is amplified and compared to a trigger threshold set by the microcontroller. When the signal exceeds the trigger threshold a PMT trigger is generated.

A PMT trigger starts two charge integrators. The charge integrators integrate the buffered input signal delayed by 500nS if the 100nS trigger filter is selected or 1600nS if the 375nS trigger filter is selected. These delays allow for the entire pulse area to be integrated. The first integrator, optimized for short pulses, integrates the delayed input signal for 1.5 $\mu$ S. The second integrator, optimized for longer pulses, integrates the delayed input signal for 6 $\mu$ S. The integrators save their charge for 25 $\mu$ S then reset unless a higher level trigger is generated. These charge integrators have a dynamic range and resolution to measure signals from about 10 photoelectrons to 40,000 photoelectrons.

The PMT trigger also starts a third integrator, integrating a constant current, for recording the PMT trigger time. This trigger time integrator has a resolution better than 15nS and a dynamic range of 20 $\mu$ S.

The sixteen PMT triggers on the ommatidial board are sent to a RAM trigger pattern look up table to determine if the pattern of PMT triggers is consistent with a cosmic ray track crossing the subcluster. If a track pattern is identified, a subcluster trigger is generated. When a subcluster trigger occurs, a subcluster save signal is generated to prevent the charge integrals from resetting for an additional 25 $\mu$ S.

Subcluster triggers from the sixteen ommatidial boards are sent to the trigger board that uses a trigger pattern look up table to identify a pattern of subcluster triggers consistent with a cosmic ray track crossing the mirror. When such a pattern is identified, a mirror trigger is generated.

When a mirror trigger occurs, the trigger board sends a mirror save signal to all the ommatidial boards for the mirror to prevent the charge integrators from resetting. Ten microseconds later, to allow the cosmic ray track to finish crossing the mirror, the trigger board generates a holdoff signal that inhibits new PMT triggers from occurring, stops the PMT trigger time integrator and interrupts the ommatidial board micro- controllers. The holdoff signal is also sent to the central timing crate to latch the absolute WWVB time of the cosmic ray event and a 24 bit 25nS scaler for the relative timing between mirror trigger events. When the ommatidial boards receive a mirror holdoff interrupt, the ommatidial boards digitize the PMT charge integrals and the PMT trigger time integrator that has an output voltage proportional to the time from the PMT trigger to the mirror holdoff. When the ommatidial boards finish digitizing the PMT charge and trigger time integrals they send a "digitizing complete" message to the VME crate controller CPU.

The crate controller CPU reads the PMT charge and trigger time data from the ommatidial boards and WWVB minute and millisecond data from the trigger board and sends this data in a ethernet packet to the central control workstation. The crate controller CPU then commands the trigger board to clear the mirror save and holdoff signals to prepare for a new trigger event. The deadtime to read out the ommatidial board and trigger board data for each mirror trigger event is less than 10 milliseconds.

The PMT trigger rates are monitored by the ommatidial board's microcontroller. In the standard mode of operation, a desired count rate is set and the ommatidial board adjusts the PMT trigger thresholds dynamically to achieve this desired count rate. This scheme of automation has been proven with years of operation of the Fly's Eyes to be an effective way to maximize the sensitivity of the detector to cosmic ray shower

tracks against a variable night sky background. The mirror crate CPU continuously monitors PMT trigger rates and thresholds, PMT high voltages, mirror trigger rates and deadtimes and other operation parameters for on-line detector status and diagnostics.

#### 4.CALIBRATION

The Hires experiment requires measurement of the absolute system gain from the PMT to the ommatidial ADC's. We have built in the mirror crates internal calibration for both the charge and time integral measurements. The programmable pulse generator boards are used to inject pulses of programmed width, amplitude and delay to the preamplifiers at the PMTs. Such calibrations are performed regularly, up to several times per night, to monitor drifts and malfunctions.

#### 5.FUTURE PLANS

There are a few areas for which one can enhance the performance of the Hires data acquisition system. For example, at present the overall event trigger rate of 14 mirrors is about 10 Hz, with only a small fraction being true cosmic ray tracks. While our system can easily handle this rate, the amount of data recorded will increase as we expand the prototype to two full sites as planned. One can reduce the data processing load by introducing more intelligent secondary triggers. Inter-mirror trigger signals will be added to let each mirror know if the other mirrors see a track. Such information will increase efficiency for triggering on dim tracks as well as decrease noise triggers. We can also install a software filter at the mirror crate level to further screen out noise events. Another improvement being planned is to replace the current sample and hold scheme of charge and time measurements with flash ADCs, which will record the entire wave form of the PMT signals for more detailed studies ( Bird et al, 1993 ).

#### REFERENCES

Bird D. et al 'The High Resolution Fly's Eye ( HiRes ) Project', ( 1993 ) this conference, OG 10.  
Bird D. et al 'Flash ADC for the HiRes Project', ( 1993 ) this conference, OG 10.

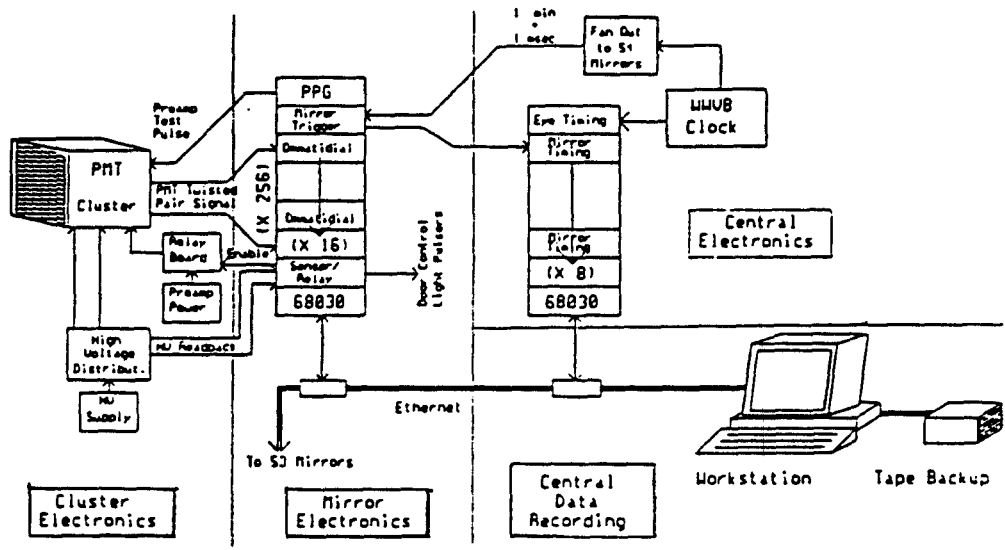

Figure 1: HiRes Eye Data Acquisition System Block Diagram.

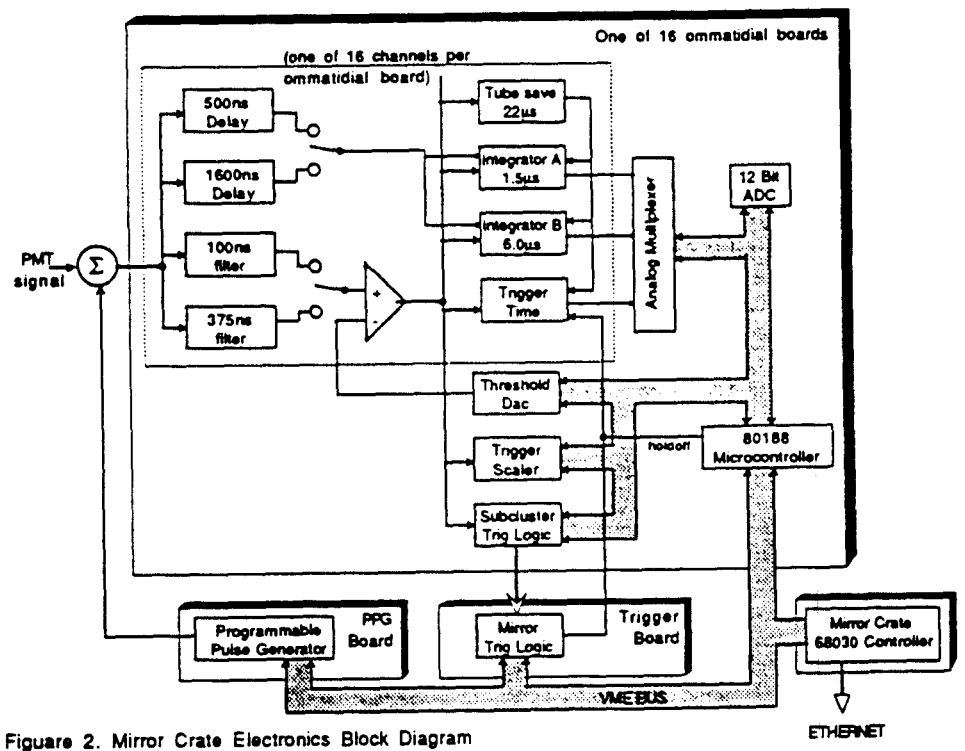

Figure 2. Mirror Crate Electronics Block Diagram