

---

## The Absolute Calibration of the HiRes Detectors

---

J.N. Matthews and S.B. Thomas for the HiRes Collaboration  
*University of Utah, Department of Physics and  
High Energy Astrophysics Institute, Salt Lake City, Utah, USA*

---

### 1. Abstract

The HiRes experiment studies Ultra High Energy Cosmic Rays (UHECR) using the air fluorescence technique. The experiment uses large mirrors that collect the fluorescence light and focus it onto arrays of photomultiplier tubes (PMTs). The PMTs measure the intensity and time of arrival of the collected light. Our primary system for in situ calibration of the PMTs uses a high stability ( $<1\%$ ) portable light source. This source is transferred from the lab to the field where it is employed as a standard candle to calibrate the 64 detectors ( $>16,000$  PMTs). To determine the absolute response it is necessary to understand the absolute light output of this source. We have measured the source irradiance using a hybrid photodiode system, two NIST calibrated photo-diodes, and by observing the photoelectron statistics of the PMTs. The results are presented.

### 2. Introduction

The goal of the High Resolution Fly's Eye (HiRes) project is to study cosmic rays at the highest energies. An ultra high energy cosmic ray entering the earth's atmosphere collides with atmospheric nuclei triggering the development of an Extensive Air Shower (EAS). The EAS emits fluorescence light as it develops. HiRes uses the air fluorescence signal to measure properties of the primary cosmic ray particle.

The fundamental detector elements in HiRes are photomultiplier tubes (PMTs). The light from an EAS is collected by large mirrors and focused into cameras each consisting of 256 PMTs [1]. Routine monitoring and calibration of the PMTs and associated electronics are crucial to the proper interpretation of the data.

The primary system for in situ calibration of the PMTs involves the use of a high stability portable xenon flash lamp. The Roving Xenon Flasher (RXF) offers several advantages. The pulse-to-pulse variation in intensity is very small  $\sim 0.3\%$  and the stability over a night is better than 2%. The emission spectrum of the RXF is sufficiently broad to allow calibration over a wide range of wavelengths. It is also readily transported from camera to camera and site to site. The RXF thus provides a standard candle that can transfer our calibration from controlled laboratory conditions to the harsh environment in the field. The main drawback of this system is that it is quite time consuming and labor intensive.

Initial calibrations with the RXF used standard PMTs inserted into each cluster. The standard PMTs were calibrated against an NIST calibrated diode [2, 3]. The RXF uniformly illuminates the PMTs in the cluster including the standard PMTs. The response of the remaining PMTs in the cluster were compared to that of the standard PMTs to determine their absolute responsivity.

Routine monitoring of the PMT gains is accomplished by analyzing the statistical distribution of signals from YAG laser flashes routed to each mirror via fiber optics [4], or by the identical analysis of the signals from the RXF. The measured ADC distributions are analyzed to estimate the number of collected (i.e. reach the first dynode and are subsequently amplified) photo-electrons [5]. This method does not require an *a priori* knowledge of the absolute irradiance of the calibration light source. The irradiance of the light source can be determined, to a reasonable accuracy, *a posteriori* by using the site wide average number of measured photo-electrons, the average quantum efficiency (QE) measured by the PMT manufacturer, and the average effective area of the PMTs. Once the source irradiance has been established, the responsivities of the individual PMTs can be computed [5].

The remaining systematic uncertainty in the overall photometric scale of the experiment is reduced by measuring well calibrated atmospheric laser shots [6] and by comparison with the scale as determined by the earlier Standard PMT calibration.

To further reduce the absolute uncertainty we must improve the measurement of the absolute irradiance of the RXF and of the atmospheric lasers. Two new reference detectors have been purchased from NIST for this purpose. These are NIST 39077C, Hamamatsu S2281 silicon photo-diodes calibrated from 200 nm to 1100 nm. [7] The absolute uncertainty over our range of interest is less than 1

However, the NIST diodes cannot be used directly to measure the irradiance of the RXF. Hybrid Photo-Diodes (HPDs) or PMTs are used to measure the irradiance of the RXF. These detectors are able to accurately measure the  $\sim 1$  microsecond flashes produced by the RXF and can be directly calibrated against the NIST diodes.

The HPD or PMT to be calibrated is placed along side an NIST photo-diode in a dark box. The detectors are simultaneously illuminated by a diffuse and uniform DC flux of monochromatic light as shown in figure 1..

First the NIST diode is used to measure the absolute flux of the light source. Next, a neutral density filter is inserted in front of the HPD to achieve an acceptable single photo-electron (SPE) counting rate. The NIST diode is also used to measure the attenuation factor for the filter. The efficiency of the HPD is then simply the ratio of incident source irradiance to the SPE rate.

Using two NIST diodes allows us to return one diode to NIST for calibration while continuing to use the second diode. We are also able to routinely compare measurements made using both diodes. Initial results show excellent agreement; well within the expected uncertainties.

Each time an HPD is used to measure the RXF, we first determine the SPE

## May 2003 HPD Calibration Setup

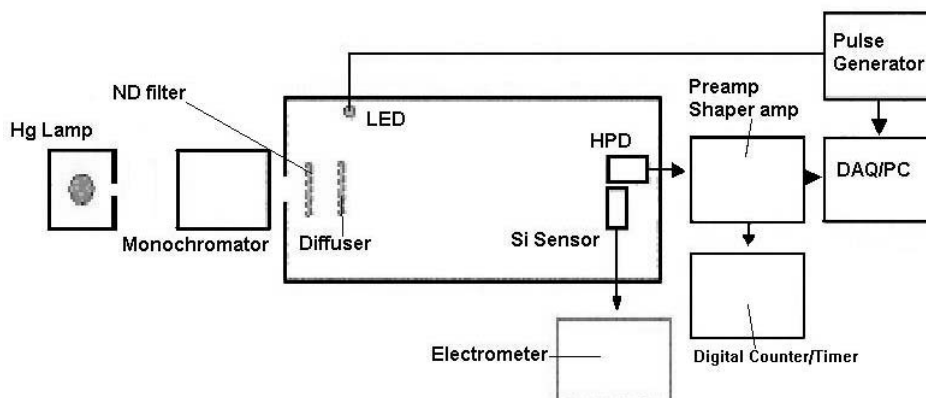

**Fig. 1.** Diagram of HPD calibration setup.

gain of the HPD. The output of an LED is attenuated to produce  $\sim 1$  photo-electron per flash. The SPE gain of the HPD is then determined from the measured charge distribution. By repeating this measurement each time an RXF is to be calibrated, we correct for uncertainties introduced by variations in the gain of the HPD and test the reproducibility of the method.

Once the SPE gain of the HPD has been determined we use the HPD to measure the output of the RXF. The measured charge translates into a number of photo-electrons via the SPE gain. This in turn gives the number of photons per unit area using the efficiency. The RXF is measured before and after each field calibration to determine its absolute irradiance and stability.

Similarly, the background subtracted output current of a PMT can be measured against the NIST diodes to directly measure its responsivity. The PMT can then be used to measure the irradiance of the RXF. The HPD is preferable to a PMT in some circumstances due to the additional uncertainties introduced by effects such as variations in dark current, higher sensitivity of the PMT gain to variations in supply voltage, magnetic fields, etc.

The calibrated RXF is then used as a standard candle. It is transported to the field where it is used to directly illuminate the detector PMTs. The same RXF is carried from detector to detector and from site to site to calibrate every PMT in the experiment. Several detectors at each site are repeated to verify stability of the RXF during the course of a calibration. Finally, the RXF is returned to the lab where it is re-measured to verify its absolute irradiance and overall stability.

### 3. Conclusion

We have constructed an absolute calibration system using two NIST calibrated photo-diodes as the primary standard. A HPD and a Roving Xenon Flasher allow us to transfer this standard into the field and calibrate all of the photomultiplier tubes of the HiRes experiment. This technique significantly reduces the overall systematic uncertainty in the absolute energy scale of the HiRes experiment.

In the near future, the HPDs and PMTs calibrated against the NIST diodes will also be employed to directly measure the scattered light from our atmospheric lasers. In this way, we will be able to tie the end-to-end photometric scale of the experiment and the channel by channel calibration of individual PMTs to our primary NIST standard diodes.

We also plan to use these calibrated detectors to measure the output of programmable UV LED flashers. These programmable sources allow us to measure the response of the PMTs over a wide dynamic range in amplitude as well as width of signals.

Results will be presented at the 2003 ICRC in Tsukuba, Japan.

### 4. Acknowledgments

This work is supported by U.S. National Science Foundation grants PHY-9322298, PHY-9974537, PHY-9974537, PHY-0098826, PHY 0071069, and PHY-0140688 in addition to Department of Energy grant FG03-92ER40732, and the Australian Research Council. We gratefully acknowledge the contributions from the technical staffs of our home institutions and the Utah Center for High Performance Computing. The cooperation of Colonels E. Fisher and G. Harter, the U.S. Army, and the Dugway Proving Ground staff is appreciated.

### 5. References

1. Abu-Zayyad T., *et al.*, 1999, Proc. of the 26th ICRC **5** pg. 349 and Abu-Zayyad T., *et al.*, 1997, Proc. of the 25th ICRC **OG 10.6.2** and **10.6.3**
2. Matthews J.N., *et al.* 1997, HiRes Internal Memo.
3. Abu-Zayyad T., *et al.*, 1997, Proc. of the 25th ICRC **10.6.4**
4. Girard J.H.V., *et al.* 2001, Nucl. Instr. and Meth. **A 460**, pg. 278.
5. Jones B.F., *et al.* 2001, Proc. of the 27th ICRC, **2**, pg. 641.
6. Mannel E., *et al.* 2003, Proc. of the 28th ICRC, Tsukuba, Japan.
7. Larason T.C., *et al.* 1998, NIST Spec. Pub. 250-41.