

OBSERVATIONS OF EXTENSIVE AIR SHOWERS BY AIR FLUORESCENCE
DESCRIPTION OF EXPERIMENTAL TECHNIQUES

G. W. Mason

Department of Physics, Brigham Young University
Provo, Utah (USA) 84602

H. E. Bergeson, G. L. Cassiday, T.-W. Chiu, D. A. Cooper, J. W. Elbert,
E. C. Loh, D. Steck and W. J. West

Department of Physics, University of Utah
Salt Lake City, Utah (USA) 84112

J. Boone

Department of Physics, California Polytechnic State University
San Luis Obispo, California (USA) 93401

J. Linsley

Department of Physics, University of New Mexico
Albuquerque, New Mexico (USA) 87131

We describe an experiment carried out at Volcano Ranch, New Mexico, to simultaneously measure extensive air showers by means of an air fluorescence detector and a conventional, ground-based, particle-sensitive scintillator array. The optical emission observations were made with an instrument which is a prototype for a large-scale air fluorescence detector (Fly's Eye).

1. Introduction. In understanding and extracting the physics which is available from the study of extensive air showers (EAS), it is very desirable to have data which give a picture of the longitudinal development of the shower. Such a longitudinal "picture" of individual showers can be made by observing the passage of a shower across the night sky using fluorescence light from excited atmospheric nitrogen molecules. The isotropic emission of this light from the path of the shower provides a means of viewing the showers from considerable distance, thus giving a compact instrument a considerable ($\sim 10^9 \text{ m}^2$) effective sensitive area. Several pioneering groups (Greisen, 1965; Chudakov, 1962; Suga, 1962; Tanahashi, 1969; Tanahashi, 1975) have proposed and attempted to examine the air fluorescence signal from showers, but the experiments have met with limited success. Although signals have been reported, they have been too weak to obtain a significant event yield. We describe here recent observations of the longitudinal development of showers by their optical emission. The showers impacted in the Volcano Ranch extensive air shower array and, hence, a detailed comparison for purposes of intercalibration has been made. The results of the experiments are reported in a series of papers included in the proceedings of this conference (Cassiday et al. 1977; Bergeson et al. 1977; Elbert et al. 1977). The present paper confines itself primarily to a description of the layout and operating conditions for the experiment.

2. Description of the Apparatus. Volcano Ranch near Albuquerque, New Mexico, USA is the site of a long-standing extensive air shower array (Linsley et al. 1962; Linsley and Scarsi, 1962; Linsley, 1963). The array is located at an altitude of 1770 meters (835 g/cm^2) in an arid region especially suitable for the operation of an optical detector because of the excellent viewing conditions permitted by the clean air and clear skies. The elements of the array are 0.8 m^2 scintillation counters. In the present configuration the 79 counters are laid out uniformly to cover a roughly hexagonal area of 1.7 km^2 .

The optical detectors were located in the plane of the scintillator array at a point 1.53 kilometers to the southeast of the array center (hence outside the array) and positioned so the field of view covered most of the array. Thus, most showers observed in the Volcano Ranch array during the experiment potentially could be seen by the optical detectors. The arrangement is shown in Figure 1.

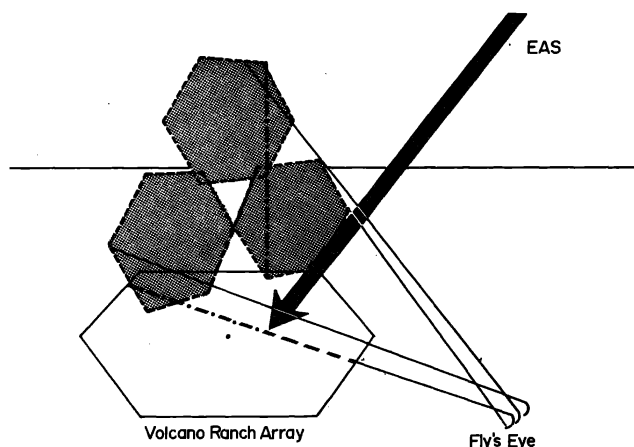

Fig. 1. Experimental Layout

The optical detectors are shown schematically in Figure 2. Light from the shower trajectory is gathered by a 1.5 meter spherical mirror ($f/1.0$) and reflected to an array of 12 photomultiplier tubes located in the focal plane of the mirror. The light is funnelled to the tube faces by close-packed hexagonal Winston funnels (Winston, 1970) which are mounted to the front of the phototubes. Each phototube images a separate section of the sky with a field of view of 5.8 degrees along the maximum diameter of the hexagon. Three mirror assemblies, each with 12 tubes, were used in this experiment to image the sky over the Volcano Ranch array as shown in Figure 1. The two outside mirrors were pointed 15 degrees above the horizontal and the center mirror was pointed 30 degrees above the horizontal. The obscuration resulting from mounting the phototubes in the field of view of the mirror is approximately 13%. The reflectivity of the mirrors has been measured in the laboratory and corrected slightly for field conditions (dust, water spots, etc.) to give 85 ± 5 percent. The funnel surfaces have an estimated 80 ± 10 percent reflectivity, but since 30% of the light goes directly to the tube face without reflection on the funnel, the effective reflectivity is 86 ± 7 percent. The combined light gathering efficiency is thus 73 ± 7 percent. The characteristics of the optical detectors are summarized in Table 1.

The phototubes are specially constructed 9-stage, super S-11 venetian blind type devices (EMI 9861B) with 23% peak quantum efficiency and extended ultraviolet response (the nitrogen fluorescence spectrum has strong lines between 3000 Angstroms and 4000 Angstroms). They were operated with typical

gains of 5×10^4 . Signals from the tube were current amplified by a factor of 200 at the base of the tube.

A simplified schematic of the data handling system is shown in Figure 3. To extend the sensitivity and dynamic range of the measurements, the signal from a given phototube was split into so-called "fast" and "slow" channels. In each case the signals were integrated to provide an input to a Schmidt trigger. The voltage level at the Schmidt inputs was controlled on-line by a computer to optimize the triggering sensitivity. The Schmidt outputs were used to generate coincidences and to control a gate to the signal integrator. The signal was delayed by cable to allow this gate to be established. In the "fast" channel the integration time was ~ 300 nsec and in the "slow" channel it was ~ 800 nsec. Once integrated, the levels were held for sufficient time for a decision to be made as to whether the pulse was shower-related, then released or passed to the computer depending on the outcome of that decision. The integrated signal is proportional to the charge produced by the phototube, which in turn is proportional to the shower size during the time the shower is in view of the tube, provided the light observed is the isotropically emitted fluorescence light and not contaminated by the forward beamed Cerenkov light.

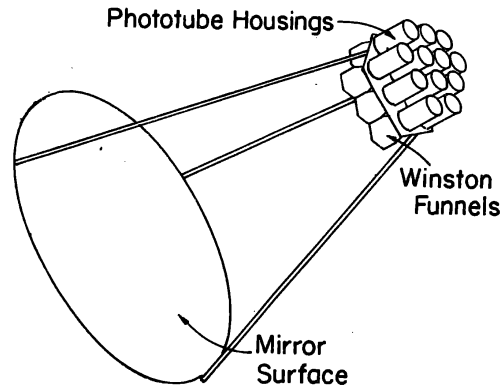

Fig. 2. Mirror unit with Winston funnels and phototube cluster.

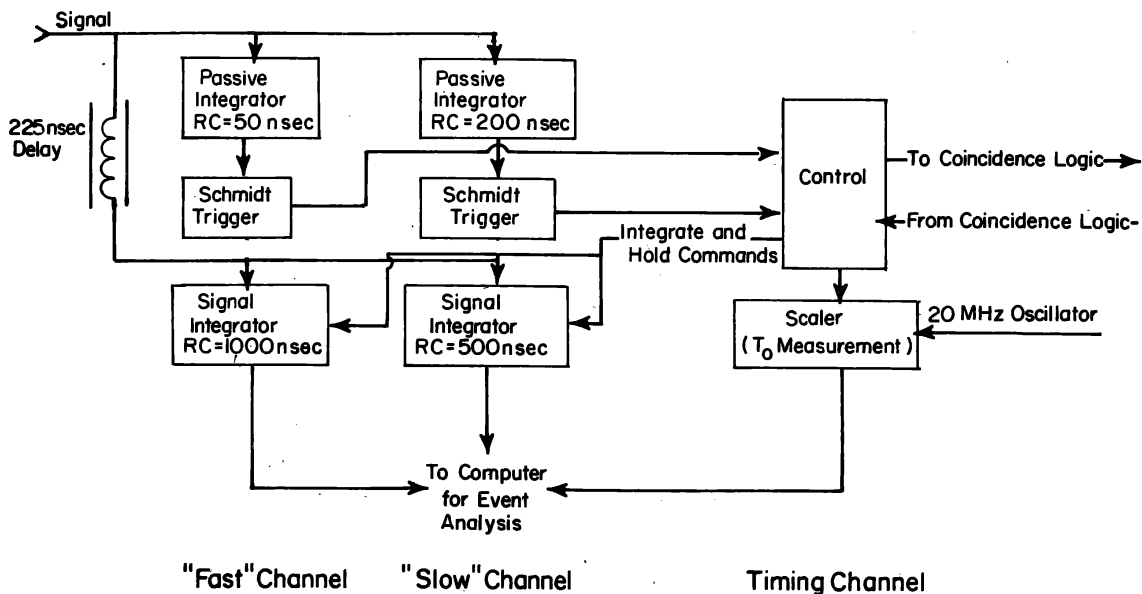

Fig. 3. Schematic of the data handling system for the optical detectors

Table 1

Optical Detector Characteristics

Number of phototubes	36
Phototube type	EMI 9861B, 3.5 inch Super S-11
Full cone angle/phototube (along maximum diagonal of hexagon)	0.10 radian
Solid angle/phototube	0.0066 steradians
Funnel area	149 cm ²
Number of large gathering mirrors	3
Distance from mirror center to front of funnel	1.50 meters
Mirror diameter	1.57 meters
Mirror f-number	f/1.0
Mirror obscuration (η)	13%
Mirror off-axis aberration (δ)	~0.02 radians
Electronics time resolution	50 nsec
Mirror reflectivity	85 \pm 5 percent
Effective funnel reflectivity	86 \pm 7 percent
Combined light gathering efficiency	73 \pm 7 percent

The measurements provide timing information crucial to the reconstruction of the trajectory of the shower. Each phototube was provided with a periodically re-synchronized scaler clocked at 20 MHz. The rising pulse in the 'fast' channel halted the scaler, thus marking T_0 , i.e., the time when the shower came into the view of the phototube. Subtractions of time for succeeding phototubes in the path of the shower yield the time the shower was in the field of view of each phototube. For showers traveling at the velocity of light parallel to the faces of the tubes, these times are simply related by geometry to a rough measure of the distance of the shower from the detectors. With a 20 MHz clock our timing resolution was 50 nsec. A typical shower in this experiment was within the field of view of a single phototube for 250 nsec.

The device was designed to provide its own trigger. The trigger requirement was flexible, but generally a coincident signal from two tubes in each of two mirrors provided an acceptable shower trigger. In preliminary testing in the mountains near Salt Lake City, showers were in fact observed in this way. However, at Volcano Ranch triggers were generated and provided solely by the Volcano Ranch array. The coincidence pulse from the scintillators was used to trigger a camera flash unit. The resulting light flash was collimated by several feet of six-inch diameter plastic pipe, travelled line-of-sight from the Volcano Ranch Station to a phototube located about 100 meters from the mirrors (to the side). The pulse from this receiver provided the signal to transfer to the computer the pulse heights and timing information currently being held by the data collection system. Triggers were provided for showers of size 2×10^7 particles or larger, but not all such showers were close enough to provide signals over threshold in the optical detectors. The smallest shower observed by the Volcano Ranch array and by the optical detectors as a complete track was 2×10^7 particles (size estimate from the Volcano Ranch data); the largest was 6×10^8 particles.

3. General Description of Ambient Light and Atmospheric Conditions. Although the major part of the data handling system was housed in a 40-foot trailer, the mirrors and phototube clusters were unprotected and set outside on simple stands. During the day covers were placed over the funnels and over the mirrors to protect them from dust, moisture and sunlight. The optical detectors were roughly located on a line drawn through the center of the Volcano Ranch array and the city of Albuquerque (about 25 kilometers distant). The city lights were directly visible from the site of the optical detectors, but were screened from the light funnels by the electronics van. Until a severe blizzard finally shut down the experiment, the nights were clear and cold. Ambient light levels were constant (as measured by the phototubes) with two exceptions. One windy night the ambient levels remained 50-100% higher than normal. This was presumably because of light from the city being scattered by dust in the air. The second exception occurred early one morning when ambient levels suddenly dropped precipitously. A visual inspection revealed that it was beginning to snow! The bulk of the running time was during moonless periods, but some running time was possible with the moon up (in its early phases) by disconnecting the high voltage to two or three tubes. A few shower tracks were observed under these slightly moonlit conditions.

4. System Tests. The gains of each phototube and current amplifier were carefully measured in several ways under controlled laboratory conditions before the experiment (Cassiday et al. 1977). Operating voltages for each tube were determined which would result in equal sensitivity and curves were generated to allow quick determination of the gain of any tube for any given operating voltage. Periodically during the course of the experiment in situ tests of the relative sensitivity of each phototube channel were made using a light pulser. Finally, a selection of 10 tubes were re-evaluated in detail in the laboratory after the close of the field measurements in order to understand any drifting in sensitivity of the detectors.

The light pulser used in the in situ testing was built along lines suggested by Kerns and Tusting (1963). A GE W1A argon glow lamp with the carbon resistor removed from the base was pulsed with a 4 kilovolt, 10 nsec pulse to provide a light pulse. The light pulse rises in a few nanoseconds, then decays slowly over several microseconds. Because of nitrogen present in the atmosphere of the bulb, the output is a good representation of the spectrum of light detected from showers. The light pulse was "piped" through Dupont Type 1610 Crofon light guides to small openings drilled for them between the Winston funnels. The bundles were 1/8 inch (3.2mm) in diameter and 7.6 meters long. Four bundles served each mirror. The light emerged from the end of the bundle, was collected by the mirror and reflected back to the funnels and hence to the phototubes. The four bundles were positioned to give a uniform signal to all 12 phototubes in a cluster.

The light pulser was computer controlled. Upon command the computer initiated a series of 100 pulses and assembled distributions of response for each tube in the array. Distributions of this type revealed a systematic decrease in the sensitivity of the detectors amounting to about 20% over the two weeks of the experiment. A careful washing of the mirror surfaces with distilled water to remove the accumulation of dust resulted in restoring less than one-fourth of this loss. A more detailed discussion of the calibration

of the phototubes, including a discussion of possible sources of this problem are given by Cassidy et al. (1977).

5. Conclusion. We have described generally the apparatus and operating conditions for a successful observation of extensive air showers by means of their optical emission, including showers which by reason of their geometry are candidates for showers having been observed by means of their fluorescence light. Over a period of thirteen nights, 44 showers were observed both by the Volcano Ranch EAS array and by the optical detectors. Of these, sixteen were unmistakable shower tracks. The trajectories are known in three dimensions and, hence, a detailed intercalibration of the two observation techniques can be made.

6. Acknowledgements. This work is supported by the National Science Foundation, Washington, D. C., USA.

References

- Bergeson, H.E. et al. 1977, accompanying paper in these proceedings.
 Cassidy, G.L. et al. 1977, accompanying paper in these proceedings.
 Chudakov, A. 1962, 5th Inter-American Seminar on Cosmic Rays (Bolivia).
 Elbert, J.W. et al. 1977, accompanying paper in these proceedings.
 Greisen, K. 1965, Proc. 9th Int. Conf. on Cosmic Rays (London), p. 609.
 Kerns, Q.A. and Tusting, R.F. 1963, Internal Report UCRL-10895, Lawrence Radiation Laboratory.
 Linsley, J., Scarsi, L. and Rossi, B. 1962, J. Phys. Soc. Japan 17 Suppl. A-III, p. 91-102.
 Linsley, J. and Scarsi, L. 1962, Phys. Rev. 128, p. 2384.
 Linsley, J. 1963, Proc. 8th Int. Conf. on Cosmic Rays (Jaipur) 4, p. 77.
 Suga, K. 1962, 5th Inter-American Seminar on Cosmic Rays (Bolivia).
 Tanahashi, G. et al. 1969, Proc. 11th Int. Conf. on Cosmic Rays (Budapest) EAS 4/2, p. 24.
 Tanahashi, G. et al. 1975, Proc. 14th Int. Conf. on Cosmic Rays (Munich) 12, p. 4385-4390.
 Winston, R. 1970, Journal of the Optical Society of America 60, p. 245.