

MODEL SSP-7

PRECISION PHOTOELECTRIC PHOTOMETER

TECHNICAL MANUAL FOR

THEORY OF OPERATION AND OPERATING PROCEDURES

***** IMPORTANT *****

**PLEASE READ THIS MANUAL
THOROUGHLY BEFORE ATTEMPTING
TO OPERATE THE PHOTOMETER**

 ***OPTEC, Inc.***

OPTICAL AND ELECTRONIC PRODUCTS

**info@optecinc.com
http://www.optecinc.com**

**199 Smith St.
Lowell, MI 49331
U.S.A.
(616) 897-9351
(616) 897-8229 FAX**

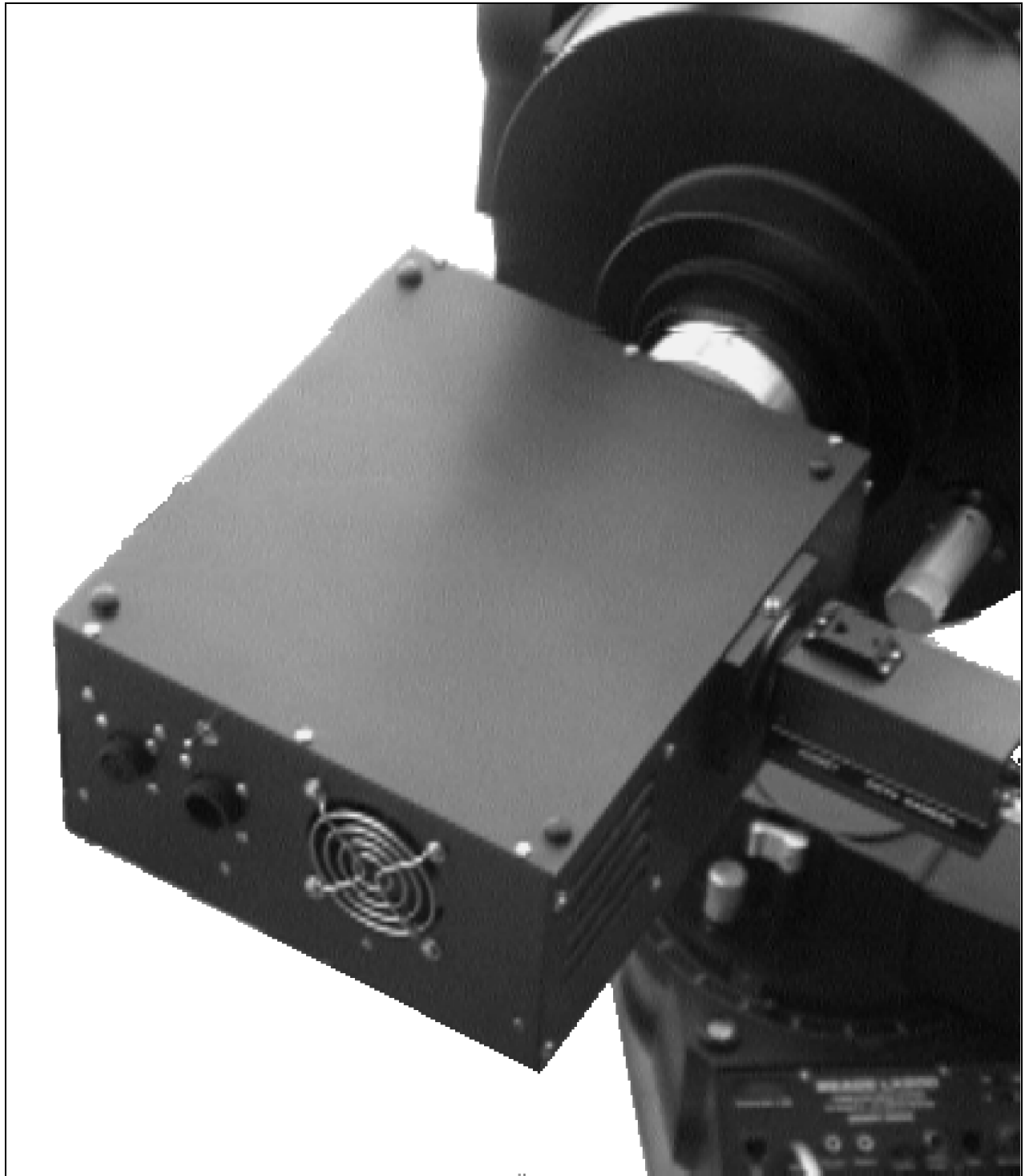

SSP-7 Precision Photometer mounted on Meade 10" Schmidt-Cassegrain Telescope.

TABLE OF CONTENTS

Revision 5 – March 2001

<i>Section</i>		<i>Page</i>
1.0	Theory of Operation	2
1.1	Photometer Head - an overview	2
1.2	PMT/PMT Housing	2
1.3	Field Aperture	3
1.4	Fabry Lens	4
1.5	Flip Mirror and Viewing Port	5
1.6	Filters/Filter Wheels	5
1.7	Interface Board - Overview	5
	1.7.1 High Voltage Power Supply	6
	1.7.2 Preamp & Low Pass Amplifier	6
	1.7.3 V/F Converter	7
	1.7.4 Counter	8
	1.7.5 Temperature Sensor/Heater	8
	1.7.6 Temperature Sensor/PMT Cooler	9
1.8	OPTEC-1 Single Board Computer	9
2.0	Operation	11
2.1	Setup	11
2.2	Programming	11
2.3	SSP7.EXE - Instrument Control Interface	12
2.4	SSP7.EXE Operation	12
2.5	Single Board Computer Operating System	14
3.0	RTL Glossary	15
4.0	Troubleshooting Guide	19
5.0	Specifications	20
6.0	Johnson Filters	22
7.0	Strömngren Filters	26
<i>Appendices</i>		
A	OPTEC-1 SBC Computer Ports	A-1
B	Digital I/O Cross Reference List	B-1
C	SBC Computer Connector Pin Cross Reference List	C-1
D	SSP-7 Wiring Diagram	D-1
E	Interface Board Component Diagram	E-1
F	Interface Board Circuit Diagram	F-1
G	Hamamatsu R4457 PMT Data Sheet	G-1

LIST OF FIGURES

<i>Figure</i>		<i>Page</i>
1-1	Cross-sectional view of the SSP-7 Precision Photometer.	1
1-2	Fabry lens system.	4
1-3	Circuit function diagram.	7

LIST OF TABLES

<i>Table</i>		<i>Page</i>
1-1	Important Computer Specifications.	10
6-1	Physical Characteristics of the Optec Filters.	22
6-2	Standard UBVR response functions according to Johnson.	23
6-3	R4457 normalized response with Optec UBVR filters.	24
6-4	Transmission of the Optec UBVR filters.	25
7-1	Optical specifications of Strömgren filters.	26
7-2	Physical specifications of Strömgren filters.	27

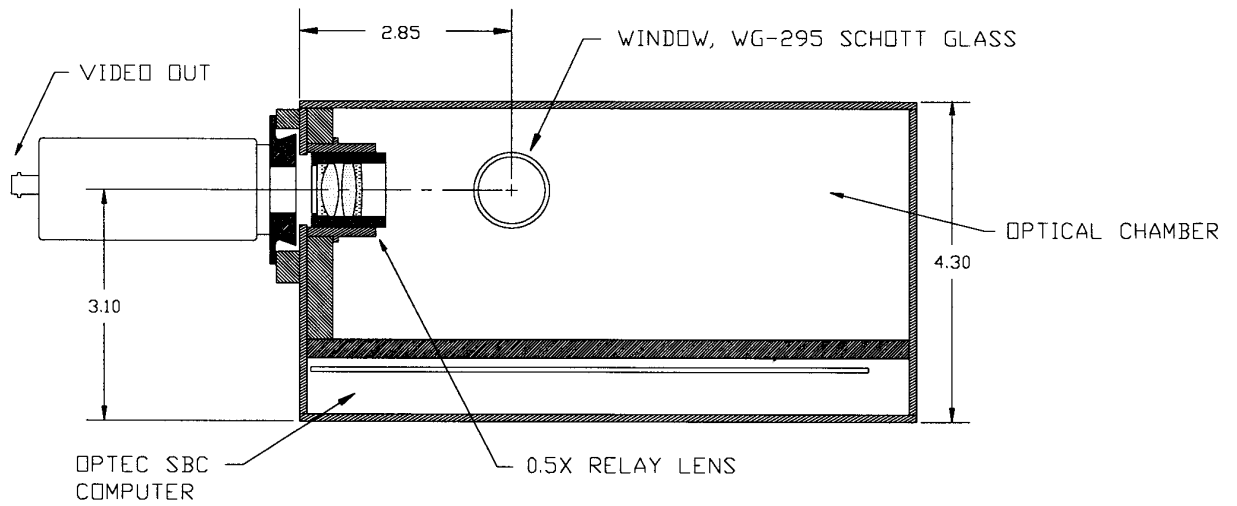
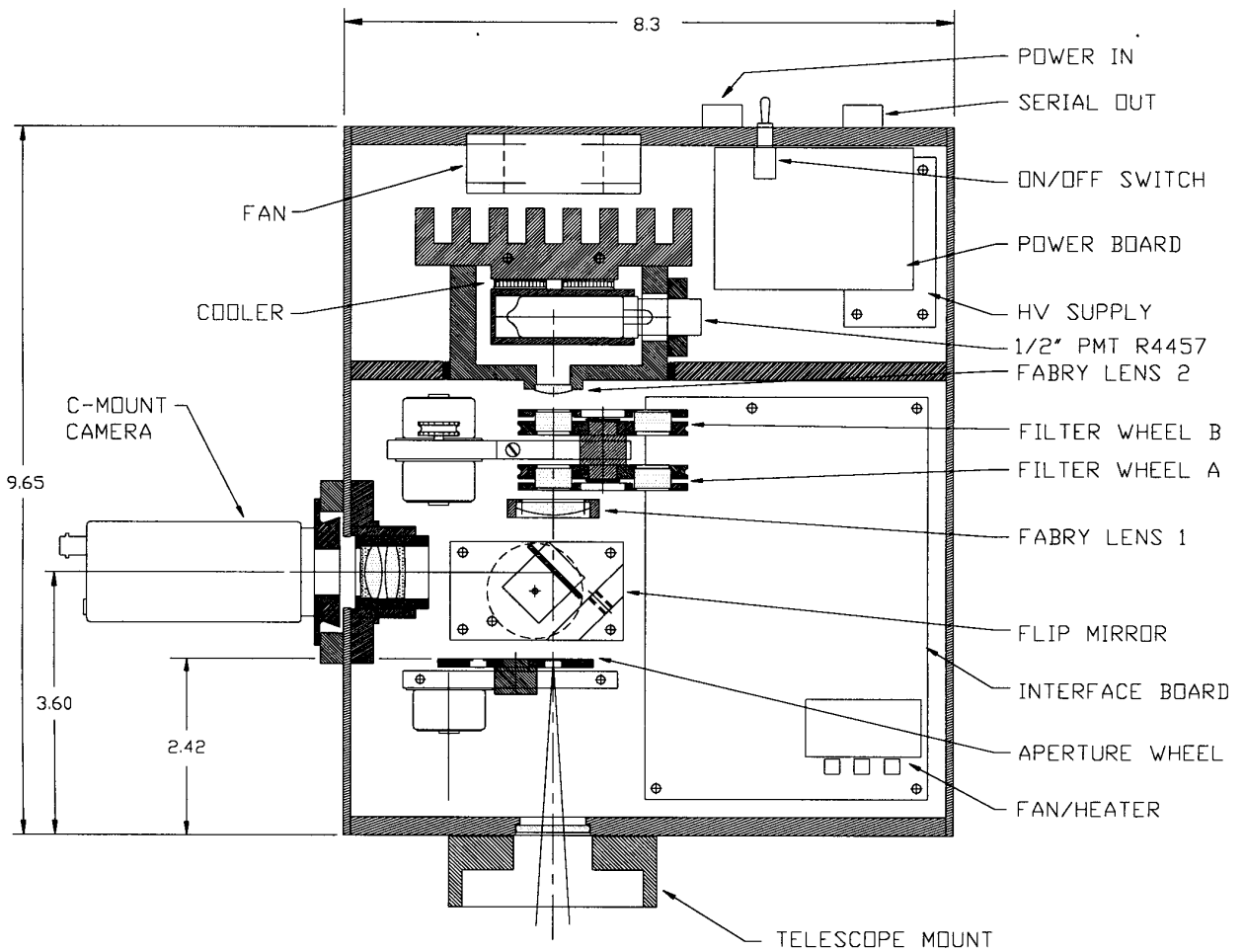

Figure 1-1. Cross-sectional view of the SSP-7 Precision Photometer.

SECTION 1.0

THEORY OF OPERATION

1.1 PHOTOMETER HEAD - AN OVERVIEW

A cross-sectional view of the photometer head is shown in Figure 1-1. Light enters the photometer through a 1 inch diameter UV transmitting window. The focal plane of the telescope lies at the motorized iris diaphragm from which a field from 0.8 to 15.0 mm can be selected with 0.1mm resolution. The light from this pupil is directed either to the view port (User) or the photomultiplier tube (PMT) by means of a motorized flip-mirror. The view port can accommodate real-time video camera with 1/2" CCD size. After a star is centered with the field aperture diaphragm fully opened, the aperture is closed to the desired field diameter, and then the flip-mirror is rotated to allow light to pass to the PMT. A two part Fabry lens system projects an image of the primary mirror/lens onto the photocathode of the PMT. Within the Fabry lens system are two 8-position filter wheels. The cooled PMT is housed in a magnetic and electrostatic shielded housing with a molecular sieve desiccant unit for obtaining an extremely dry ambient atmosphere. Interface electronics are contained within the temperature stabilized optical chamber. A CMOS computer (Optec model SBC) with on board operating system is housed in a shielded compartment below the optical chamber. All functions of the photometer are controlled via the Optec SBC with a high level command language over a RS-232 link.

1.2 PMT/PMT HOUSING

Optec currently offers the SSP-7 with a miniature 9-stage, side-on, multialkali PMT of high quantum efficiency and very low dark current. This PMT, designated model R4457, is manufactured by Hamamatsu Corporation and measures only 40 mm long by 14 mm in diameter. At the operating voltage of -800 VDC and after several hours of warm-up, this PMT has a typical dark current of around 0.7 pA at -5° C temperature and a current gain of 1,000,000. This dark current is equivalent to around 5 photoelectrons per second rate. The quantum efficiency at the center of the Johnson V band, 540 nm, is approximately 16% for the R4457.

The multialkali photocathode of this PMT permits measurements within a 185 to 830 nm window. However, the UV transmitting glass window at the entrance port of the photometer head has a 295 nm cut off. This allows the photometer to effectively measure stars with the Johnson and/or Cousins UBV_R, the Strömgren uvby and the H β systems. See appendix G for a detailed description of the R4457 PMT.

A steel shield of high permeability is placed around the PMT to reduce the effect of external magnetic fields (dome motors, the earth's field, conductors inside the SSP-7, etc.) on the path of photoelectrons in the tube. See Figure 1-1. In addition the shield is brought to the same potential as the photocathode, so that photoelectrons are not drawn to the glass tube. To protect against shock hazard, the shield is connected to the high voltage supply through a 22 M ohm current limiting resistor.

The default value for the operating temperature is -5° C with a drift of less than 2° C. The near constant temperature that the PMT is operated at will considerably reduce the gain and spectral response drift due to temperature changes.

As discussed by Miles¹ (1986) the dark current of a PMT is decreased substantially by dehumidifying the tube in a desiccating chamber. This apparently reduces current leakage around the tube pins and socket connectors to a minimum. Before assembly, the tube and socket used in the SSP-7 are placed in a vacuum desiccator for several days before they are installed into the SSP-7. To insure continued dry operating conditions, a rechargeable molecular sieve canister is used on the side of the PMT housing. The canister should keep the interior air of the PMT housing dry for periods of a six months. However, reactivating the molecular sieve by baking at 300° F for 4 hours is suggested every year or when the PMT is removed for service. Contact Optec for additional desiccant canisters.

1.3 FIELD APERTURE

The SSP-7 uses a motorized six position aperture wheel for setting the field of view. Through software control any position can be selected. The default aperture sizes are:

Position	Size (diameter)
1	14mm*
2	2.00
3	1.00
4	0.75
5	0.50
6	0.25

* full aperture for camera viewing

Each aperture hole is precision drilled into the wheel. At time of order, any size from 0.25mm to 5.00mm can be specified for positions 2 through 6. Position 1 is reserved for camera viewing for the purpose of identifying the field and centering the object of interest. The smallest diameter would be selected consistent with the seeing disk of the star and adjacent background stars.

¹ Miles, R. 1986, *IAPPP Communication* 24, 6.

1.4 FABRY LENS

Because the photomultiplier tube's cathode surface has very poor response uniformity, a Fabry lens is needed to fill a large area of the cathode uniformly without regard to where the star is positioned within the field aperture. Considering an $f/10$ cone of light, the Fabry lens system used in the SSP-7 will image the telescope's entrance pupil slightly past the wire mesh screen in front of the photocathode with a spot having a diameter of 3.2 mm. Telescopes with f -ratios in the range of 8 to 16 should work with the standard lens system. See Figure 1-2 for a description of the Fabry lens system used in the SSP-7.

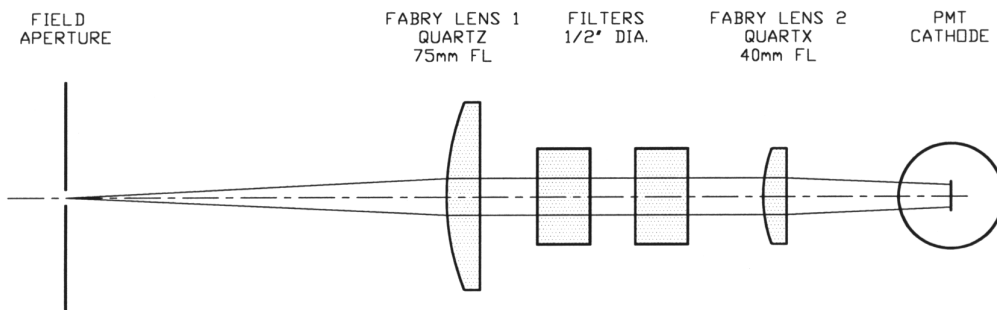

Figure 1-2. Fabry lens system.

The first lens in the system produces a nearly parallel bundle of rays from the entrance $f/8$ to $f/16$ cone. This allows the filters between the two lenses to perform to their specifications since they are designed for rays normal to their surfaces. The second and stronger lens images the entrance pupil onto the photocathode surface of the PMT.

Both lenses are made from the highest quality optical quartz polished to a 40-20 scratch and dig specification. This material will allow the SSP-7 to perform well into the UV. However, quartz optical material will produce scintillating flashes due to cosmic rays and other high energy particles. This might compromise the data of dim objects. If requested, Optec would replace these lenses with normal optical glass lenses which do not show this effect but will cut UV transmission to 360 nm. The effect of cosmic rays is dependent on altitude with a higher rate proportional to higher altitudes. The user will have to make their own judgment on this matter before specifying the Fabry lens material since these lenses must be factory installed.

1.5 FLIP MIRROR AND VIEWING PORT

The motorized flip mirror has two positions which allow either the PMT or the focusing camera to view the light passing through the iris diaphragm. In the PMT position the mirror is positioned away from the beam. In the viewing position the mirror is positioned at 45° to the optical axis in order to direct the beam to the side viewing port. The exact rotational position of the mirror is adjustable by use of a small setscrew on the flip mirror mount.

Between the mirror and the viewing port is a relay lens system that re-images the field at the iris diaphragm onto the focusing camera. The relay lens system has a small amount of longitudinal adjustment which will allow an exact focus to be achieved on the iris diaphragm with these cameras. Use of a real-time video camera for target acquisition is the preferred method for this photometer.

1.6 FILTERS/FILTER WHEELS

Two motorized 8-position filter wheels are positioned between the two Fabry lenses. These wheels can hold any of our 1/2" diameter 7 mm thick filters and are rotated by a miniature step per motor. Normally, a clear window would be mounted in position #8 for each filter wheel so that colored glass or interference filters can be mounted in either wheel at the user's discretion. One or the other clear filter would always be left in the optical path. A dark or opaque filter is placed in position #1 of either wheel by default.

In addition to the standard UBVR Johnson filters, the four color (uvby) Strömgren and Hydrogen β wide and narrow filter sets are available. In case bright objects are measured, a neutral density filter with a transmission of 1.0% is available for mounting in either wheel. See Section 6.0 and 7.0 for Johnson and Strömgren filter specifications.

Because the optical chamber of the SSP-7 is temperature stabilized at 35° C, the normal filter passband drift due to changing temperature is nearly eliminated. During normal operation, the interior chamber temperature will remain within 5° C of the set point.

To establish filter position #1 for each filter wheel during power up, the wheels are rotated a sufficient amount to insure that each is brought in contact to a machined stop position, thus stalling the stepper motor. From that point, which establishes position #1, each of the other 7 positions are obtained by sending to the stepper motor of each wheel a known number of steps in the desired direction.

1.7 INTERFACE BOARD - OVERVIEW

The Interface board used in the SSP-7 contains all of the important signal processing functions, key elements of the high voltage power supply, stepper motor control and temperature control functions. This board is mounted within the optical chamber to take advantage of the constant temperature feature of this area for the purpose of reducing component temperature drifting. With the maximum 5° C temperature drift, gain drifting of the various circuits is insignificant.

1.7.1 INTERFACE BOARD - HIGH VOLTAGE POWER SUPPLY

For stable PMT operation an extremely well regulated and low noise high voltage power supply is needed. The gain of the PMT used in the SSP-7 is proportional to the 7th power of the applied voltage. Thus, for small values a percent change in gain is equal to 7 times the percent change in the applied voltage. For example, a 1 volt change at -800 VDC is equal to a .8% change in PMT gain, or nearly a 0.01 magnitude error. Following a 30 minute warm-up time, the voltage stability for the SSP-7 is ± 0.1 V for periods of at least 15 minutes. In the bandwidth of 1 to 0.05 Hz, the voltage noise is less than 0.1 V.

The high voltage supply (see Figure 2-3) uses a 20 kHz oscillator to drive a pot core transformer with a 1 to 55 turn ratio. A voltage doubler and rectifier circuit produces a maximum voltage of about -900 VDC when fully powered. The output is regulated down to the working voltage of -800 VDC by feeding a fraction of the output to a high-gain difference amplifier which compares the output to a very stable voltage reference (10ppm T-C) and amplifies the difference as a correcting voltage to the pot core voltage driver. A failure of the feedback mechanism will not overdrive the PMT causing an expensive tube replacement since the maximum voltage that can be produced is approximately -900 VDC, which is within the maximum ratings of the PMT.

If the PMT is exposed to bright lights such as the moon or a bright planet, permanent damage could result to the anode stage of the tube. To prevent this, the output of the preamp is connected to a protection circuit which will turn off the high voltage within a few milliseconds when the preamp output nears its saturation point. When this happens a HV out signal is sent to the SBC computer and interface program. The HV can in turn be enabled through software command.

1.7.2 INTERFACE BOARD - PREAMP & LOW PASS AMPLIFIER

Even with the million fold gain of the PMT, the output current is still very small, on the order of picoamperes for dim stars. This current has to be amplified sufficiently for the V/F converter to work properly without introducing gain instabilities or noise to the output signal.

The preamp used in the SSP-7 is divided into two stages. The first stage is a current-to-voltage amplifier with two user selectable gains of 7.9×10^6 for the high gain setting and 7.9×10^5 for the low setting. The output voltage is related to the input current from the PMT by the following equation:

$$E_{\text{out}} = \text{GAIN} \cdot I_{\text{in}}$$

The amplifier used is an Analog Devices model 549K electrometer which has a bias current of less than 0.1 pA and noise currents much smaller. The second stage is a low pass amplifier (LT1008) of 1.5 gain which also inverts the signal since the V/F converter needs a negative voltage level. The total measured voltage drift is $6 \mu\text{V}/^\circ\text{C}$ and output noise is less than $0.1 \mu\text{V}$ in the DC to 350 Hz bandwidth of interest. A single photoelectron event will generate an average $1.4 \mu\text{V}$ output from the preamp/low pass.

The response time is defined as the time taken for the output signal to go from 10% to 90% of its final value. The response time of the low pass amp is 1 millisecond.

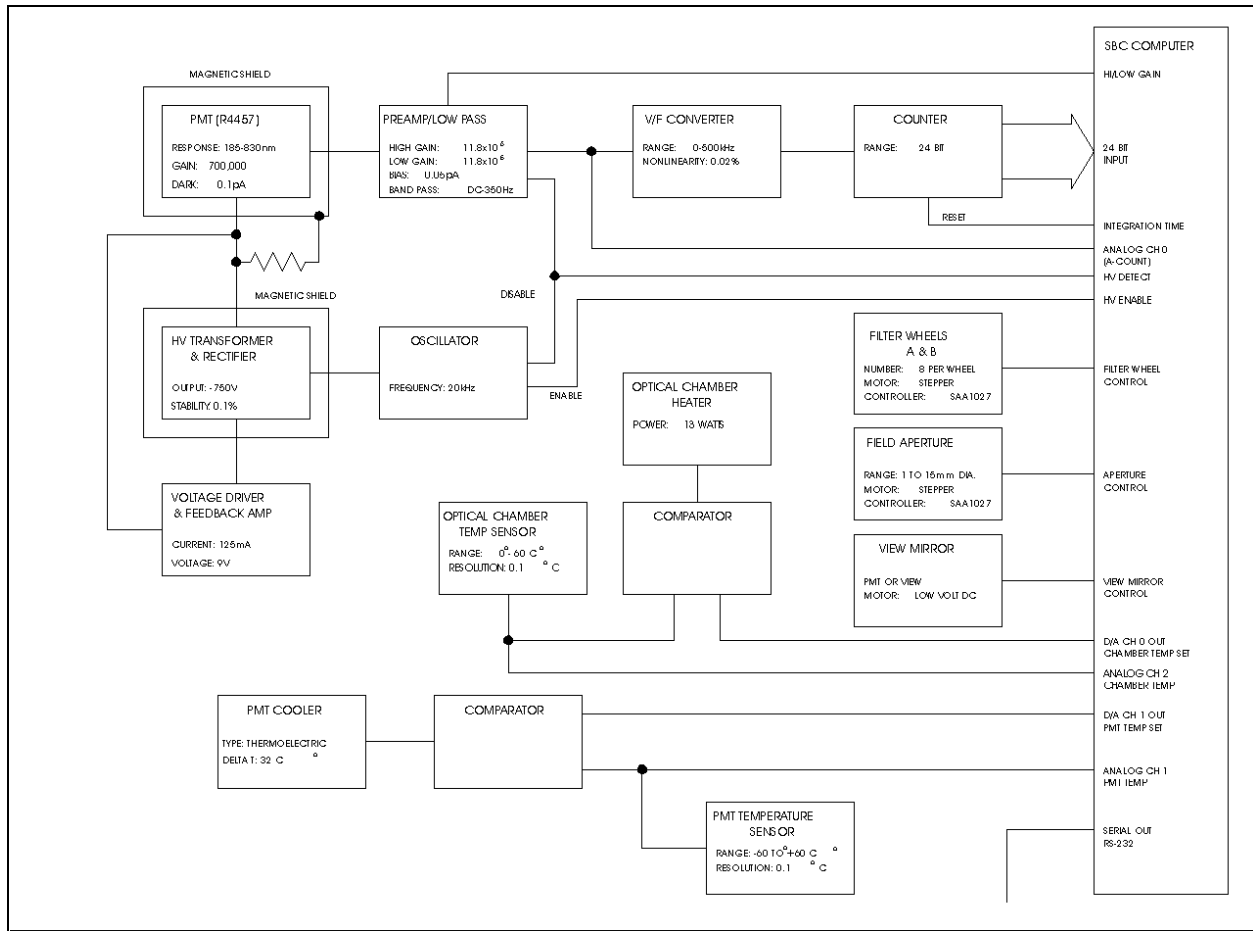

Figure 1-3. Circuit function diagram.

1.7.3 INTERFACE BOARD - V/F CONVERTER

Since the SSP-7 is operating in a DC mode as compared to other PMT photometers which operate in a photon (pulse) counting mode, it is important to distinguish the difference between the pulses coming from the V/F converter and the photons of light. They are not the same. This becomes very important when considering dark count. The 'dark' count of the SSP-7 is the sum total of PMT dark current (true dark current or count), preamp offset voltage and V/F amplifier offset voltage. The last two sources are usually many times higher than the dark current but are not treated in the same way as PMT dark current. The offset voltage is set high in order that there is some negative voltage going into the V/F converter at all times resulting in a count. The counter will not count backward if input noise voltages change polarity; that is, go from a negative to a positive voltage. When the SKY count is subtracted from the STAR count as normally done in the reduction process, this offset error will be nulled to 0.

Another significant difference the V/F measuring mode has compared to pulse counting is that dead time corrections are not used. The pulse count from the V/F is directly proportional to light flux with insignificant nonlinearity errors.

A model AD652 monolithic synchronous Voltage-to-Frequency converter is used to convert the voltage source from the preamp to a pulse train that can be counted. The obvious advantage of this method is that counting pulses for a long integration time is far more accurate than an analog integrator. An analog integrator would have to contend with large leakage errors for integration times approaching 10 seconds. In addition, greater dynamic range and higher signal to noise ratios are achievable with pulse counting.

This high quality V/F converter has a typical nonlinearity error of 0.002% and a maximum value of 0.02%. The maximum gain temperature coefficient is ± 50 ppm/ $^{\circ}$ C and since the circuit is temperature stabilized to 5° C drift, the maximum gain error from this source can only be 0.025%. The full scale pulse rate is 500,000 Hz, thus a 1 second integration will give this V/F measurement technique the equivalence of a 19-bit A/D conversion. With the integration time of 1 second, 1 ADU is equal to 20μ V output from the preamp.

1.7.4 INTERFACE BOARD - COUNTER

A 24-bit ripple counter is used to accumulate the pulses from the V/F converter for the specified integration time. Once the count is accumulated, the output is read in parallel by the SBC computer and then reset. The counter will overflow with a count over 16,777,216 which is 2^{24} .

1.7.5 INTERFACE BOARD - TEMPERATURE SENSOR/HEATER

An active temperature sensor is mounted near the filter wheel which produce an output voltage proportional to temperature from 0 to 60° C. This output, after scaling, is directly compared to an analog value provided by D/A channel 0 (optical chamber set temperature) of the SBC computer. The comparator output is used to operate a resistive heating element with maximum power dissipation of 13 watts. A fan located directly in front of the heater mixes the internal chamber air to minimize temperature differences. Insulating foam is secured to all interior walls to prevent heat loss to the outside. A temperature uniformity of 5° C is normally obtained within the optical chamber. If the ambient air temperature is warmer than 25° C, a higher optical chamber temperature set point is recommended. If the ambient temperature is lower than 0° C, a cooler set point is recommended.

The scaled temperature sensor voltage output is also connected to the analog-to-digital channel 2 input of the SBC computer. This digitized signal is then displayed as temperature to a resolution of 0.1° C.

1.7.6 INTERFACE BOARD - TEMPERATURE SENSOR/PMT COOLER

A temperature sensor is attached to the steel shield of the PMT tube near the Peltier cooler. The voltage output of this sensor is proportional to temperature in the range from -60 to +60° C. Located near and surrounding the PMT, it can be assumed that the temperature of the shield is close to the PMT temperature.

The Peltier cooler is directly connected to the 12 VDC supply and uses about 2 amps of current. By running the cooler at full power switching this current is avoided and the potential transient noises are also eliminated. To temperature regulate the PMT to a set temperature (default value of -5° C), the scaled output of the sensor is compared to an analog value provided by D/A channel 1 (PMT set temperature) of the SBC computer. The output of the difference amplifier is used to operate a resistive heating element located within the steel PMT shield with a maximum power dissipation of 5 watts. Heating the cold side of the Peltier cooler takes less power and allows keeping the operating temperature of the PMT at -5° C when the ambient temperature is between 0°C and 30°C. A lower set point is needed at ambient temperatures below 0°C. The temperature drift error is approximately 2° C. The Peltier device can be turned off by program control.

The scaled temperature sensor voltage output is also connected to the analog-to-digital channel 1 input of the SBC computer. This digitized signal is then displayed as temperature to a resolution of 0.1° C.

1.8 OPTEC-1 SINGLE BOARD COMPUTER

The OPTEC-1 SBC (Signal Board Computer) has been designed by Optec to take advantage of low power CMOS ICs entirely. Based on the Hitachi 64180 microprocessor, the computer consists of a single 9" by 7.5" board with the important specifications listed in Table 1-1. The computer operating system and signal processing program are written in a unique language called RTL which stands for "Relocatable Threaded Language". RTL is a variant of the language Forth and as such it contains many of the features which have made Forth such a successful language. The nature of RTL lies somewhere between assembly language for speed and other higher level languages for easy and flexible programming.

When reset or powered on, the computer immediately computes a checksum number for the program on EPROM and checks it with a stored value also on the EPROM. If a mismatch occurs, the computer will stop and transmit an error message on the serial output line. This insures the integrity of the program before data is collected.

CPU	64180 from Hitachi 6.144 Mhz clock rate Automatic reset via watchdog timer
Memory	48K EPROM 16K RAM 50 bytes non-volatile RAM
I/O	64 lines bidirectional
A/D	12-bit resolution +3.0 to -3.0 input voltage range 8 μ sec conversion time 4 multiplexed differential inputs
D/A	12-bit resolution 2-outputs 0 to +10 or 0 to +5 output range
Real Time Clock	year:month:day:hour:minute:second 10 Year battery life
Serial Port	RS-232 port with the following functions available: RX - TX - CTS - RTS - DCD & GND up to 9600 baud

Table 1-1. Important Computer Specifications.

SECTION 2.0

OPERATION

2.1 SETUP

Before turning the unit on make sure that both the view port and the telescope port are blocked letting no light enter the unit. The SSP-7 will turn the high voltage off once the unit detects an over exposure situation but that will happen only after boot up which may take 1/2 second. Damage to the tube could result in that time.

In order to access the optical chamber to change filters, PMT, or other service items; remove the top cover that is marked "OPTICAL".

To access the computer card remove the bottom cover that is marked "COMPUTER".

To change filters, remove the single flat head screw located in the middle of the filter assembly and gently pull up on the assembly. Follow the stepper control cables to the interface board and remove them. Filter wheel "A" is the one closest to the front (telescope mounting) of the enclosure. The filters are held in place by a black aluminum cover which can be removed by undoing the center pan head screw. CAUTION: Once the cover is removed all of the filters are now loose and can be removed. Filter position #8 is reserved for the Clear filter in each filter wheel. If one or more dark filters are used, they should be placed in the Home position (#1) of either wheel to ensure the PMT is not saturated during filter changes with the mirror in the PMT position.

The unit will self initialize with the default values indicated in the Glossary.

The RS-232 interface pin list for the 9-pin output connect is specified in Appendix C, Connector J3. Only three wires are needed and lengths up to 100 ft. should not be a problem. Baud rate is 9600, 8 data bits, no parity and 1 stop bit.

2.2 PROGRAMMING

The RTL Glossary of commands described in Section 3.0 allows the programmer to control the SSP-7 photometer by sending the proper Esc sequence to the on-board computer via an RS-232 link. Data and instrument parameters are sent back as requested. The programmer would need to use these basic commands to write a data acquisition program in order to operate the photometer in an automated mode through the serial port of the user's computer.

In programming an initialization sequence during power-up of the photometer, the following sequence is recommended:

- a. Set the PMT temperature value.
- b. Set the optical chamber temperature value.
- c. Home both filter wheels and select a dark position.
- d. Select a field aperture value.
- e. Select a amplifier gain value.
- f. Select an integration time.
- g. Select a VIEW position for target positioning.
- h. Select an interval value for the number of integrations.
- i. Check HV-DETECT to see if the high voltage supply is running. If not, find out why before proceeding.
- j. Monitor PMT and optical chamber temperature until desired values are achieved before proceeding.
- k. Ready to take data.

2.3 SSP7.EXE - INSTRUMENT CONTROL INTERFACE

The SSP7.EXE interface program allows the operator to control all functions of the SSP-7 photometer and acquire data. While not intended to be used as a fully automated data acquisition system, this interface program will allow the user to acquire data in RPHOT readable files for later reduction. Consult the *RPHOT Automated Data Acquisition and Reduction Software Package for Aperture Photometry User's Manual* for a description of the data reduction techniques used. Observing List script files are permitted which will allow for some increase in the data taking rate with this program interface.

The SSP-7 interface program will run by itself (i.e. the program includes all run-time modules) and also includes all source code and libraries. Any PC with a VGA monitor and a serial port will work as a data acquisition and instrument control computer.

2.4 SSP7.EXE OPERATION

Select the **Setup** pull-down and select the **Init Comm** function. Prompts will appear in the [Message] window asking for a Comm Port and Baud Rate. Enter the desired communications port (usually 1 or 2) and 9600 for the baud rate. These values can also be stored in the SSP7.CFG configuration file for automatic initialization when the program is

started. After initialization, the user can **Set PMT Temp** and **Set Filter Temp** if the desired temperature setpoints for the optical (filter) chamber and PMT chamber are different than the defaults. The PMT cooler can be enabled (default) or disabled from this pull-down. Night vision mode (red screen) and the local time settings can also be selected. Catalog Error Checking is a feature for users reducing their data with the RPHOT software package. RPHOT applies to Johnson photometry only and the Catalog Error Checking option simply ensures the user inputs a valid catalog designation. (*See the RPHOT User's Manual for additional detail.*) With this option inactive, any one character string can be used as a catalog name.

Once communication with the SSP-7 is established, the software will cause the instrument to perform an initialization procedure similar to that described in Section 2.2 above. The program will then enter a loop mode where basic operating conditions are looked at continuously. The results are posted in the [**Instrument Status**] window. The idea for the different status windows at the bottom of the screen is that values in the [**Object Status**] window are printed to the output data file (if one has been opened) and values in [**Instrument Status**] window are the current operating conditions of the SSP-7 instrument. The A/D output (A-COUNT) is also continuously updated in the [**Instrument Status**] window as **Analog**: (negative values are normal). The [**Time**] window displays both UT and local times and dates.

Basic instrument settings are selected in the **Parms** pull-down. Here the user can control such instrument operating parameters as integration time, aperture and gain settings, and reading interval. From this menu the user can also home the filters and re-enable the PMT High Voltage if necessary. The user can switch the position of the flip-mirror (**Switch View**) from this menu or simply press the F2 key to flip between the User (typically a video camera view) and PMT settings. To set the filters wheels to a particular filter or combination of filters, use the **FiltA** and **FiltB** pull-downs. The values for each filter position are stored in the ASCII file FILTERS.CFG which can be edited with any text editor.

The **Run** pull-down menu allows the user to actually take readings with the SSP-7. Select **Read Trial** to take a single integration or **Run Slowmode** to start a series of integrations (number of integrations depending on the current Interval value). The trial reading will not prompt for Object and Catalog values like the standard reading and will not be written to an open data file. The results of the integration are posted in the [**Count Status**] window along with the UT time/date corresponding to end of the integration was completed. During a long integration or interval, the user can interrupt the data acquisition cycle by pressing the Escape key. The current integration will complete before returning control to the user. The other selections in this pull-down allow the user to initiate a Fastmode observing run or read an OList file for an automated Observing List (*see RPHOT for details*). The **Run Olist** option will only be highlighted if an OList file has already been opened in the File pulldown. OList files (*.OLS) are generated with the external LISTGEN.EXE program to plan an observing session automatically fill in many of the prompts generated during a typical Slowmode observing session.

The current version of SSP7.EXE allows fast-mode operation of the SSP-7 instrument using 20, 50, or 100 millisecond integrations. Before beginning the timed fast mode, the user must select the number of integrations (**Intervals**) and the integration time. The **Run Timed** option will initialize the SSP-7 instrument and prompt the user to press the spacebar to start the integrations.

The fastmode run can be halted with an escape key press. Otherwise data taking will continue until the number of integrations specified in the FInterval have completed. Data is stored in the SSP-7 local RAM until called for by the user with the **Read FData** option. However, a data file must be opened before the FREAD can be started. The SSP-7 instrument will calculate a checksum of the data which is first read by the SSP7.EXE program. This insures a complete and error-free data stream from the SSP-7 instrument. A long FREAD can last several minutes or more. Refer to Section 3.0 for more details on the nature of the data stream.

The **Object** pull-down is designed to allow the user to enter the observing details for a particular integration. For example, the **Object Name** and **Catalog** can be entered from this pull-down along with the sky type (**Sky**, **SkyNext**, or **SkyLast** - see *RPHOT User's Manual* for a full explanation). Note that the user will be prompted for object (star name or sky type) and catalog during a read so these values need not be entered from the pull-downs. In fact, the object and catalog will be read from the OList file if one is being used. Selecting the **Filter** option will prompt the user to enter the desired filter in the [Message] window. A valid filter selection will force both filter wheels to move. The wheel containing the desired filter will move to that filter and the other wheel will move to the Clear filter (position #8 by default). If a user wishes to place an ND (neutral density) filter into the light path, that filter should be selected manually under the **FiltA** or **FiltB** pull-downs. **Comments** can be added after any reading and will be stored in an open data output file.

The **File** pull-down allows the user to **Open** and **Close** an output data file. All data is stored in RPHOT readable ASCII data files for reduction with the RPHOT software package. See the *RPHOT Automated Data Acquisition and Reduction Software Package for Aperture Photometry User's Manual* for further information. The **Open** selection will prompt the user for the various parameters required by the RPHOT reduction program. Also under the **File** pull-down is the **Terminal** emulation mode toggle. Communication with the SSP-7 on-board computer can be established with any terminal program using the 9600 baud setting with 8-N-1 parity and bit settings. The terminal program available with the SSP7.EXE program is rather rudimentary and was designed primarily for simple diagnostic and de-bugging work. A full-featured terminal program using Televideo 920 emulation is recommended for extensive direct communication with the SSP-7 single-board computer.

2.5 SSP-7 SINGLE-BOARD COMPUTER OPERATING SYSTEM

The OPTEC-1 SBC on-board computer in the SSP-7 uses our proprietary operating system called RTL. RTL is a derivative of the Forth programming language which uses stacks and words. The language is very structured and easy to use once you get familiar with it. Any of the words (commands) can be temporarily edited (program changes are lost when the power is shut off) with the EDIT command. This allows changes to be tried out before a new ROM is generated. Lengthy changes and new words can be uploaded with PROCOMM which would allow any ASCII editor to be used. The operating program can be more tailored to specific applications if necessary and a new ROM supplied. A brief listing of the most commonly used words or commands as used by the SSP-7 is provided in Section 3.0.

SECTION 3.0

RTL GLOSSARY

The following general conventions are used in this document for stack comments:

- n* - 16-bit signed number
- u* - 16-bit unsigned number
- d* - 32-bit signed number (a double number)
- ud* - 32-bit unsigned number
- c* - byte value or character, 16 bits wide but only least significant 8 bits are valid
- ?* - flag, 16-bits wide, 0=false, non-zero=true
- a* - 16-bit memory address
- p* - 16-bit port address
- f* - start or source address (from-address)
- t* - end or destination address (to-address)
- ESC - ASCII escape character (decimal 27)
- SP - ASCII space (decimal 32)
- CR - Standard carriage return.

FILT-HOME

(*n* -)

Homes filter wheel A or B and resets stepper controller.
Valid values of *n* are 1 (wheel A) and 2 (wheel B)
Code returned on serial port is - ESCF-H *n* CR

FILT

(*n*₂ *n*₁ -)

Given filter wheel (*n*₁) and filter position (*n*₂)
selects new filter. *n*₁ has valid values of 1 (A) or 2 (B)
and *n*₂ has valid values of 1, 2, ... 8.
Default value for both *n*₁ and *n*₂ is 1
Code returned on serial port is - ESCF *n*₁ *n*₂ CR

VIEW

(*n* -)

1 VIEW changes flip mirror to viewing position,
2 VIEW changes flip mirror to PMT viewing position.
Default setting is 1
Code returned on serial port is - ESCV *n* CR

FIELD	(<i>n</i> -)	Sets field aperture by position. Default value of <i>n</i> is 1 (14mm aperture size). Valid values of <i>n</i> are 1, 2, 3, 4, 5, and 6. Code returned on serial port is - ESCAP <i>n</i> CR
FIELD-HOME	(-)	Moves field aperture to position 1 and sets FIELD-POS variable to 1. Used when power first applied to photometer. Code returned on serial port is - ESCAP 1 CR
INTEG	(<i>n</i> -)	Sets integration time in units of 0.10 seconds. Default value for <i>n</i> is 10 (1 second of integration). Valid range for <i>n</i> is 1 to 600 or 0.10 to 60.00 sec. Code returned on serial port is - ESCI <i>n</i> CR
TEMP-PMT	(-)	Returns temperature of PMT in °C Format: ±XX.X Code returned on serial port is - ESCTP ±XX.X CR
TEMP-FILT	(-)	Returns temperature of filters in °C Format: ±XX.X Code returned on serial port is - ESCTF ±XX.X CR
SET-TEMP-PMT	(<i>n</i> -)	Sets PMT operating temperature in °C. Default value for <i>n</i> is -5. Valid range for <i>n</i> is -25 to 0. Code returned on serial port is - ESCSTP <i>n</i> CR
SET-TEMP-FILT	(<i>n</i> -)	Sets Filter operating temperature in °C. Default value for <i>n</i> is 35. Valid range for <i>n</i> is 25 to 40. Code returned on serial port is - ESCSTF <i>n</i> CR

INTERVAL

(n -)

Sets number of times the count is obtained before stopping. The count reading is output before starting a new count.

Default value for n is 1.

Valid range for n is 1 to 32768

Code returned on serial port is - ESCINT n CR

HV-DETECT

(- ?)

Determines if the high voltage is on or off

Code returned is - ESCHV ?

where ? = 0 when high voltage is off and

? = 1 when high voltage is on.

READ

(-)

Returns count as three 8-bit numbers (FF Hex) which represents a single 24-bit binary number. The values returned on the serial line would be in the following format - ESCC $XX\ XX\ XX$ CR

where:

$XX\ XX\ XX$ is the count in Hex

(Range is 0 to FFFFFFF Hex)

Note: it is up to the user to make sure that the count value is within the 24-bit range. Adjust integration time or filters accordingly.

A-COUNT

(-)

Returns the on-board A/D acquisition of count.

The code sent to the serial port is - ESCA $\pm XXX$ CR

where:

$\pm XXX$ is the A/D value in Hex

(Range is 0 to FFF Hex)

Note: The A-COUNT value is actually the reading from the PMT preamp output and could be used to check offset and analog condition of the PMT signal. Normally, the signal is negative going but positive values near zero may be observed due to small offset errors. The average of ten readings is result which takes approximately 0.1 seconds.

GAIN

(n -)

Sets gain of PMT amplifier, high or low.

1 sets high gain
 2 sets low gain which is 0.1 times the high gain
 Default value of n is 1
 Code returned is - ESCG n CR

HV-ENABLE

(-)

Resets high-voltage circuit after auto power off
 due to excessive light
 Code returned is - ESCEN CR

COOL

(n -)

turns PMT cooler on and off
 1 sets cooler on
 2 sets cooler off
 default value of n = 1
 code returned is -ESCCL n CR

FMODE-A

($n1$ $n2$ - CR SP)

start fastmode reading
 $n1$ set number of readings (interval)
 valid values 1 to 4000
 $n2$ set integration time
 valid values 2, 5, and 10 which represent
 20, 50, and 100 ms respectively
 CR enables fast mode
 SP starts the readings
 code returned after CR is ESC2
 code returned after data sampling is complete is ^Z

FREAD

(-)

reads back fastmode data from single board RAM
 returns series of hex numbers described as follows:

$XXXXYYYYZ_1Z_1Z_1Z_1Z_2Z_2Z_2Z_2Z_3Z_3Z_3Z_3\dots$

where each character is an eight bit byte (hex number) represents the
 ASCII numeric code.

$XXXX$ is the checksum for data,
 $YYYY$ is number of data points,
 $Z_1Z_1Z_1Z_1$ data point 1 values from 0000 to 9999 valid
 $Z_2Z_2Z_2Z_2$ second data point,
 $Z_3Z_3Z_3Z_3$ third data point,
 etc...

code returned before data is ESC1.

SECTION 4.0

TROUBLESHOOTING GUIDE

(Contact Optec for Troubleshooting the SSP-7)

SECTION 5.0

SPECIFICATIONS

DETECTOR

Type	9-stage side-on photomultiplier tube
Model	R4457 from Hamamatsu
Photocathode	Multialkali
Spectral Range	185 - 830 nm
Cathode Sensitivity	60 mA/W at 360 nm (Johnson U band) 70 mA/W at 550 nm (Johnson V band) 20 mA/W at 700 nm (Johnson R band)
Quantum Efficiency	QE=20% at 360 nm QE=16% at 540 nm QE=3.5% at 700 nm
Operating Voltage	-800 V
Gain	1×10^6 at -800 V
Rise Time	1.4 ns (PMT only)
Dark Current	<1 pA at -800V and -5° C
Operating Temperature	-5.0 ± 2° C (default value)

PREAMP/LOW PASS AMPLIFIER

Type	Current-to-Voltage for 1st Stage
Bias Current	0.05pA
Offset Voltage	<0.25 mV (adjustable to 0)
1st Stage High Gain	7.9×10^6
1st State Low Gain	7.9×10^5
2nd Stage Gain	1.5
Input Voltage Noise	4 μV(p-p) (.1 to 10Hz)
Input Current Noise	0.003 pA (.1 to 10Hz)
Maximum Output Voltage	-10 V
Pass Band Range	DC to 350 Hz
Response Time	1 millisecond

A/D CONVERTER

Type	Voltage-to-Frequency
Full Scale Frequency	500 kHz
Full Scale Input Voltage	-10.0 V
Nonlinearity	< 0.02%

COUNTER/TIMER

Integration Times (Gate)	20, 50, 200 ms (fast mode) 0.1 to 60.0 sec. 0.1sec increments (slow mode)
Timer Resolution	0.1 seconds
Timer Accuracy	0.01% at 35° C
Input	serial input, TTL level
Output	24 bit parallel, TTL level

FILTERS/FILTER WHEELS

Number of Wheels	2, Wheel A and B
Positions per Wheel	8
Size of Filter	12.5 mm Dia., 7.0 mm Thick
Filter Orientation	User selectable Position #1, Dark in either wheel (recommended) Position #8, Clear in each wheel (required)
Filters Available	Johnson U,B,V and R Strömgren u, v, b, and y Hydrogen β , narrow and wide Clear window Neutral Density 1.0% transmission

APERTURE WHEEL

Type	Wheel with 6 fixed apertures
Range	0.25 to 2.00 mm
Accuracy	± 0.01 mm
Default values	0.25, 0.5, 0.75, 1.0, 2.0 mm 14 mm for viewing

VIEW PORT

Maximum Field of View	14 mm at the focal plane
Relay lens magnification	0.5x
Maximum camera chip allowed	8.0 mm diagonal

MECHANICAL

Body Material	Aluminum 6061-T6 alloy
Finish	Black Anodized
Size	9.65L x 8.30W x 4.30H inches
Weight	9 lbs.
Telescope Coupler	made to user's specifications

SECTION 6.0

JOHNSON FILTERS

The UBV filter system established by Johnson is generally followed today for photoelectric systems using a 1P21 or equivalent photomultiplier tube. This system defines wide color bands in the spectrum interval from 300 to 720 nm. Using the red-sensitive R4457 PMT, SSP-7 owners can now perform photometry into the Johnson R band as well (out to 960 nm).

Filter-detector response is defined as the normalized product of filter transmission times detector response for each wavelength interval. Table 6-2 lists the filter-detector responses (also referred to as the response function) of the Johnson UBVR system. The filter-detector responses shown in Table 6-3 were determined using the Optec UBVR filters and the R4457 PMT. This table is provided for comparison purposes with the original Johnson responses. Table 6-4 lists the filter transmission values for the latest batch of Optec UBVR filters. These values were used to calculate the filter-detector responses shown in Table 6-3.

The Optec UBVR filters are all made from combinations of Schott colored glass. The glass types and thickness for each filter has been computer optimized for the best fit with the Johnson standards. Table 6-1 lists the physical specifications for the Optec UBVR filters.

PHYSICAL SPECIFICATIONS	
DIAMETER	12.7±0.15 mm
SURFACE QUALITY	80-50
FLATNESS	2 waves within center 6 mm
WEDGE	not to exceed 5 arc minutes

Table 6-1. Physical characteristics of the Optec filters.

wavelength nm	Johnson U	Johnson B	Johnson V	Johnson R	Johnson I
300	0.00	----	----	----	----
310	0.10	----	----	----	----
320	0.61	----	----	----	----
330	0.84	----	----	----	----
340	0.93	----	----	----	----
350	0.97	----	----	----	----
360	1.00	0.00	----	----	----
370	0.97	----	----	----	----
380	0.73	0.11	----	----	----
390	0.36	----	----	----	----
400	0.05	0.92	----	----	----
410	0.01	----	----	----	----
420	0.00	1.00	----	----	----
440	----	0.94	----	----	----
460	----	0.79	0.00	----	----
480	----	0.58	0.02	----	----
500	----	0.36	0.38	----	----
520	----	0.15	0.91	0.00	----
540	----	0.04	0.98	0.06	----
560	----	0.00	0.72	0.28	----
580	----	----	0.62	0.50	----
600	----	----	0.40	0.69	----
620	----	----	0.20	0.79	----
640	----	----	0.08	0.88	----
660	----	----	0.02	0.94	----
680	----	----	0.01	0.98	0.00
700	----	----	0.01	1.00	0.01
720	----	----	0.01	0.94	0.17
740	----	----	0.00	0.85	0.36
760	----	----	----	0.73	0.56
780	----	----	----	0.57	0.76
800	----	----	----	0.42	0.96
820	----	----	----	0.31	0.98
840	----	----	----	0.17	0.99
860	----	----	----	0.11	1.00
880	----	----	----	0.06	0.98
900	----	----	----	0.04	0.93
920	----	----	----	0.02	0.84
940	----	----	----	0.01	0.71
960	----	----	----	0.00	0.58
980	----	----	----	----	0.47
1000	----	----	----	----	0.36
1020	----	----	----	----	0.28
1040	----	----	----	----	0.20
1060	----	----	----	----	0.15
1080	----	----	----	----	0.10
1100	----	----	----	----	0.08
1120	----	----	----	----	0.05
1140	----	----	----	----	0.03

Table 6-2. Standard UBVR I Response Functions According to Johnson.

wavelength nm	OPTEC U	OPTEC B	OPTEC V	OPTEC R	R4457 PMT
300	0.00	----	----	----	0.77
310	0.00	----	----	----	0.76
320	0.00	----	----	----	0.79
330	0.15	----	----	----	0.81
340	0.40	----	----	----	0.84
350	0.61	----	----	----	0.83
360	0.92	0.05	----	----	0.86
370	1.00	0.17	----	----	0.86
380	0.82	0.36	----	----	0.86
390	0.37	0.56	----	----	0.86
400	0.00	0.71	----	----	0.86
410	0.00	0.82	----	----	0.87
420	0.00	0.94	----	----	0.89
440	----	1.00	----	----	0.91
460	----	0.76	0.00	----	0.93
480	----	0.44	0.00	----	0.95
500	----	0.26	0.59	----	0.97
520	----	0.11	0.96	0.00	1.00
540	----	0.04	1.00	0.07	0.99
560	----	0.01	0.85	0.09	0.96
580	----	0.00	0.57	0.36	0.91
600	----	----	0.29	0.71	0.86
620	----	----	0.11	0.92	0.79
640	----	----	0.03	1.00	0.71
660	----	----	0.01	0.96	0.64
680	----	----	0.00	0.86	0.57
700	----	----	0.00	0.40	0.29
720	----	----	----	0.27	0.21
740	----	----	----	0.17	0.16
760	----	----	----	0.09	0.10
780	----	----	----	0.04	0.06
800	----	----	----	0.00	0.007
820	----	----	----	0.00	0.006
840	----	----	----	0.00	0.004
860	----	----	----	0.00	0.003
880	----	----	----	0.00	0.0014
900	----	----	----	0.00	0.0000
920	----	----	----	0.00	0.0000
940	----	----	----	0.00	0.0000
960	----	----	----	0.00	0.0000
980	----	----	----	0.00	0.0000
1000	----	----	----	0.00	0.0000
1020	----	----	----	----	0.0000
1040	----	----	----	----	0.0000
1060	----	----	----	----	0.0000
1080	----	----	----	----	0.0000
1100	----	----	----	----	0.0000
1120	----	----	----	----	0.0000
1140	----	----	----	----	0.0000

Table 6-3. R4457 Normalized Response with Response Functions of Optec UBVR Filters.

Wavelength nm	OPTEC U	OPTEC B	OPTEC V	OPTEC R
300	0.00	0.00	0.00	0.00
310	0.00	0.00	0.00	0.00
320	0.00	0.00	0.00	0.00
330	0.16	0.00	0.00	0.00
340	0.28	0.00	0.00	0.00
350	0.37	0.00	0.00	0.00
360	0.48	0.04	0.00	0.00
370	0.49	0.14	0.00	0.00
380	0.39	0.28	0.00	0.00
390	0.17	0.41	0.00	0.00
400	0.00	0.50	0.00	0.00
410	0.00	0.55	0.00	0.00
420	0.00	0.60	0.00	0.00
440	0.00	0.57	0.00	0.00
460	0.00	0.39	0.00	0.00
480	0.00	0.21	0.00	0.00
500	0.00	0.11	0.49	0.00
520	0.00	0.05	0.74	0.00
540	0.00	0.02	0.72	0.00
560	0.00	0.01	0.60	0.04
580	0.00	0.01	0.40	0.16
600	0.00	0.00	0.21	0.33
620	0.00	0.00	0.08	0.44
640	0.00	0.00	0.02	0.50
660	0.00	0.00	0.00	0.53
680	0.00	0.00	0.00	0.51
700	0.00	0.00	0.00	0.46
720	0.00	0.00	0.00	0.41
740	0.00	0.00	0.00	0.34
760	0.00	0.00	0.00	0.27
780	0.00	0.00	0.00	0.21
800	0.00	0.00	0.00	0.16
820	0.00	0.00	0.00	0.11
840	0.00	0.00	0.00	0.08
860	0.00	0.00	0.00	0.06
880	0.00	0.00	0.00	0.04
900	0.00	0.00	0.00	0.03
920	0.00	0.00	0.00	0.02
940	0.00	0.00	0.00	0.01
960	0.00	0.00	0.00	0.01
980	0.00	0.00	0.00	0.01
1000	0.00	0.00	0.00	0.01
1020	0.00	0.00	0.00	0.00
1040	0.00	0.00	0.00	0.00
1060	0.00	0.00	0.00	0.00
1080	0.00	0.00	0.00	0.00
1100	0.00	0.00	0.00	0.00
1120	0.00	0.00	0.00	0.00
1140	0.00	0.00	0.00	0.00

Table 6-4. Transmission of the Optec UBVR filters.

SECTION 7.0

STRÖMGREN FILTERS

The Strömgren uvby is the most widely used intermediate-band photometric system. The letters u, v, b, y refer to the colors ultraviolet, violet, blue and yellow respectively. Because these filters have a narrow passband, the system is totally filter defined, and variations in detector spectral response, telescope transmission, and the second order terms used for the extinction corrections and the transformation equations can be safely ignored. In addition, the use of these filters provide more useful astrophysical information than the Johnson UBV system. Table 7-1 lists the filter specifications.

The vby filters are multiple cavity interference type using dielectric quarter wave stacks with spacers of metal film. They have excellent transmission characteristic and long life when properly stored. However, all interference filters can be damaged when exposed to high humidity for long periods of time. When not used, these filters should be stored in a glass jar with a small amount of desiccant added to keep the air dry. In such an environment, these filters will last virtually forever.

OPTICAL SPECIFICATIONS			
Filter	Center Wavelength	Bandpass	Type
u	342nm	25 nm	6mm UG11 + 1mm WG345
v	410±2 nm	16±1.6 nm	interference
b	470±2 nm	19±1.9 nm	interference
y	550±2 nm	24±2.4 nm	interference

Table 7-1. Optical specifications of Strömgren filters.

The u filter is made from 2 pieces of Schott colored glass. The first glass of UG11 defines the red side of the pass band and the WG345 defines the blue side. The red leak of the UG11 glass beyond 700 nm should not be a source of error with the R4457 PMT. However, when using the R3823 PMT with extended infrared response an IR-cut filter should be added to the opposite filter wheel to avoid problems with the red-leak. The surface of the UG11 glass has poor resistance to weathering (humidity) and must be protected in a manner similar to the vby filters. Unlike the interference filters which cannot be restored, the weathered surface of this filter can be re-polished. If a small amount of weathering is observed, a white haze on the surface, a Q-tip with jewelers rouge and water can normally re-polish the surface. Use light pressure and blow dry the filter immediately afterwards.

PHYSICAL SPECIFICATIONS	
DIAMETER	12.7±0.15 mm
THICKNESS	7.0±0.3 mm
SURFACE QUALITY	80-50
WEDGE	NOT TO EXCEED 5 ARC MIN

Table 7-2. Physical specifications of Strömgren filters.

Appendix A

OPTEC-1 SBC COMPUTER PORTS

OVERVIEW

The active ports of the SBC fall into two classes: ports internal to the 64180 CPU chip and ports that control external functions of the SBC. Ports 0 through 3F hex belong to the 64180 CPU. These ports control the memory management unit (MMU), direct memory access (DMA), the serial ports, memory refresh, the internal counters and timers and so forth. Consult the 64180 literature for detailed discussions of these control functions.

The external ports of the SBC begin at port address 100 hex. The first eight external ports (100h through 107h), control the eight, eight-bit parallel ports. Ports 108h through 10Bh control the two digital-to-analog converters. Ports 10Ch and 10Dh control the analog-to-digital converter and multiplexer. Ports 200h through 23Fh access the DS1286 battery-backed watchdog timekeeper chip.

THE PARALLEL I/O PORTS (100H - 107H)

The parallel I/O ports consist of eight 74HC646 registered bi-directional octal bus drivers. The eight bits of each port are configured by jumpers to be either all inputs or all outputs. Each of the eight parallel I/O port chips (U7 - U14) has an associated configuration jumper strip (SW1 - SW8, respectively). To configure a port for parallel input, jumper pin 1 to pin 2 and also jumper pin 4 to pin 5 on the associated jumper strip. To configure a port for parallel output, jumper pin 2 to pin 3 and also jumper pin 5 to pin 6 on the associated jumper strip. In each case, all other pins are left open.

There is nothing in the software which will prevent reading an output port or writing to an input port. It is the responsibility of the programmer to avoid doing this. Writing to an input port will have no effect other than briefly tying together two possibly conflicting CMOS output drivers. Reading an output port will, however, destroy the data previously latched in the port.

THE DIGITAL-TO-ANALOG CONVERTER PORTS (108H - 10BH)

There are two 12-bit digital-to-analog conversion channels on the SBC. Each channel uses its own AD7248 latched converter chip. The output range of these ADCs is unipolar in the range of 0-10 VDC or 0-5 VDC. The output range is selected by a jumper strip associated with each ADC chip (SW10 for U20, SW11 for U21). Jumping pins 1 and 2 on the jumper strip sets an output range of 0-10 VDC, pins 2 and 3 sets a range of 0-5 VDC.

Ports 108h and 109h control the AD7248 of D/A-1, and 10Ah and 10Bh control D/A-2. The higher port in each pair accesses the least significant eight bits of its 12-bit converter. The least significant four bits of the lower port control the most significant four bits of its converter. (The other bits of the lower port have no effect.)

The AD7248 uses an internal, intermediate buffer latch on the least significant eight bits of the 12-bit conversion word. These bits are latched into the converter output latch at the same time as the most significant four bits. This makes it possible to avoid any invalid converter outputs created as a result of the inevitable time delay in an 8-bit system between writing to the upper and lower latch ports. Consequently, data should always be written to the converter ports in high port-low port order.

For example, in order to write the hexadecimal number 5A3 to the first a-to-d converter, write A3 (the eight low-order bits) to port 109h and then 5 (the four high-order bits) to port 108h.

THE ANALOG-TO-DIGITAL CONVERTER PORTS (10Ch - 10Dh)

The analog to digital converter section consists of four differential input channels multiplexed by an ADG529A multiplexer to a single 12-bit AD7870 A-to-D converter. The ADC has an input range of +/- 3 VDC.

Two ports control the A-to-D converter (at 10Ch) and its associated front-end four channel multiplexer (at 10Dh). The least significant two bits of the byte written to 10Dh select one of four multiplexer channel pairs. Sampling and conversion is begun by reading port 10Ch. Before this initiating CPU read operation is completed, the converter (via its BUSY/ output) asserts the WAIT/ input to the CPU. The CPU will be kept in a wait state while conversion is in progress. When conversion is complete, the converter BUSY/ output (and CPU WAIT/ input) signal is negated and the initial read operation is completed. The byte read is the least significant eight bits of converted data. In order to read the upper four converter bits, port 50Ch is read. This asserts address line A10 which is used to select the high order four bits. Reading port 50Ch is otherwise the same as reading port 10Ch, since the I/O address space is incompletely decoded.

THE WATCHDOG TIMEKEEPER (200H - 23Fh)

The first 14 locations of the DS1286 watchdog timekeeper (200h -20Dh) constitute the control registers of the DS1286. The remaining fifty locations (20Eh - 23Fh) are freely available for use as battery-backed storage locations. These locations behave just like any other port and can be accessed via the RTL words PORT-IN and PORT-OUT. Consult the DS1286 literature for a detailed discussion of the function of this chip.

Appendix B

DIGITAL I/O CROSS REFERENCE LIST

Port 100h - U7

<u>Bit</u>	<u>Pin</u>	<u>Conn.</u>	<u>I/O</u>	<u>Signal</u>	<u>Description</u>
0	20	J2-1	O	SS1	Set Filter Stepper 1
1	19	J2-3	O	DS1	Direction Filter Stepper 1
2	18	J2-5	O	TS1	Trigger Filter Stepper 1
3	17	J2-7	O	SS2	Set Filter Stepper 2
4	16	J2-9	O	DS2	Direction Filter Stepper 2
5	15	J2-11	O	TS2	Trigger Filter Stepper 2
6	14	2-13	O	DMM	Direction Flip Mirror Motor
7	13	J2-15	O	CL	Cooler

Port 101h - U8

<u>Bit</u>	<u>Pin</u>	<u>Conn.</u>	<u>I/O</u>	<u>Signal</u>	<u>Description</u>
0	20	J2-2	O	SA	Set Aperture Stepper
1	19	J2-4	O	DA	Direction Aperture Stepper
2	18	J2-6	O	TA	Trigger Aperture Stepper
3	17	J2-8	O	HVE	High Voltage Enable
4	16	J2-10	O	HLG	HI/LO Gain
5	15	J2-12	O	RC	Reset, Counter
6	14	J2-14	O	CC	Enable Clock Counter
7	13	J2-16	O	X2	Spare

Port 102h - U9

<u>Bit</u>	<u>Pin</u>	<u>Conn.</u>	<u>I/O</u>	<u>Signal</u>	<u>Description</u>
0	20	J2-23	I	D0	Counter Out, bit 0
1	19	J2-25	I	D1	Counter Out, bit 1
2	18	J2-27	I	D2	Counter Out, bit 2
3	17	J2-29	I	D3	Counter Out, bit 3
4	16	J2-31	I	D4	Counter Out, bit 4
5	15	J2-33	I	D5	Counter Out, bit 5
6	14	J2-35	I	D6	Counter Out, bit 6
7	13	J2-37	I	D7	Counter Out, bit 7

Port 103h - U10

<u>Bit</u>	<u>Pin</u>	<u>Conn.</u>	<u>I/O</u>	<u>Signal</u>	<u>Description</u>
0	20	J2-24	I	D8	Counter Out - bit 8
1	19	J2-26	I	D9	Counter Out - bit 9
2	18	J2-28	I	D10	Counter Out - bit 10
3	17	J2-30	I	D11	Counter Out - bit 11
4	16	J2-32	I	D12	Counter Out - bit 12
5	15	J2-34	I	D13	Counter Out - bit 13
6	14	J2-36	I	D14	Counter Out - bit 14
7	13	J2-38	I	D15	Counter Out - bit 15

Port 104h - U11

<u>Bit</u>	<u>Pin</u>	<u>Conn.</u>	<u>I/O</u>	<u>Signal</u>	<u>Description</u>
0	20	J2-42	I	D16	Counter Out - bit 16
1	19	J2-39	I	D17	Counter Out - bit 17
2	18	J2-20	I	D18	Counter Out - bit 18
3	17	J2-17	I	D19	Counter Out - bit 19
4	16	J2-40	I	D20	Counter Out - bit 20
5	15	J2-41	I	D21	Counter Out - bit 21
6	14	J2-18	I	D22	Counter Out - bit 22
7	13	J2-21	I	D23	Counter Out - bit 23

Port 106h - U13

<u>Bit</u>	<u>Pin</u>	<u>Conn.</u>	<u>I/O</u>	<u>Signal</u>	<u>Description</u>
0	20	J1-15			not connected
1	19	J1-13			not connected
2	18	J1-11			not connected
3	17	J1-9			not connected
4	16	J1-7			not connected
5	15	J2-19	I	HVD	High Voltage Out Detect
6	14	J1-3			not connected
7	13	J1-1			not connected

Appendix C

OPTEC-1 SBC COMPUTER CONNECTOR PIN CROSS REFERENCE LIST

Connector J2 - 2x25 Pins

<u>Pin</u>	<u>Chip Pin</u>	<u>Port - Bit</u>	<u>In/Out</u>	<u>Signal</u>	<u>Description</u>
1	U7-20	100-0	O	SS1	Set Filter Stepper 1
2	U8-20	101-0	O	SA	Set Aperture Stepper
3	U7-19	100-1	O	DS1	Direction Filter Stepper 1
4	U8-19	101-1	O	DA	Direction Aperture Stepper
5	U7-18	100-2	O	TS1	Trigger Filter Stepper 1
6	U8-18	101-2	O	TA	Trigger Aperture Stepper
7	U7-17	100-3	O	SS2	Set Filter Stepper 2
8	U8-17	101-3	O	HVE	HI Voltage Enable
9	U7-16	100-4	O	DS2	Direction Filter Stepper 2
10	U8-16	101-4	O	HLG	HI/LO Gain
11	U7-15	100-5	O	TS2	Trigger Filter Stepper 2
12	U8-15	101-5	O	RC	Reset - Counter
13	U7-14	100-6	O	DMM	Direction Flip Mirror Motor
14	U8-14	101-6	O	CC	Clk - Counter
15	U7-13	100-7	O	CL	Cooler
16	U8-13	101-7	O	X2	Spare
17	U11-17	104-3	I	D19	Counter Out - bit 19
18	U11-14	104-6	I	D22	Counter Out - bit 22
19	U13-15	106-5	I	HVD	HI Voltage Out Detect
20	U11-18	104-2	I	D18	Counter Out - bit 18
21	U11-13	104-7	I	D23	Counter Out - bit 23
22	nc	-	-	-	not connected
23	U9-20	102-0	I	D0	Counter Out - bit 0
24	U10-20	103-0	I	D8	Counter Out - bit 8
25	U9-19	102-1	I	D1	Counter Out - bit 1
26	U10-19	103-1	I	D9	Counter Out - bit 9
27	U9-18	102-2	I	D2	Counter Out - bit 2
28	U10-18	103-2	I	D10	Counter Out bit 10
29	U9-17	102-3	I	D3	Counter Out - bit 3
30	U10-17	103-3	I	D11	Counter Out - bit 11
31	U9-16	102-4	I	D4	Counter Out - bit 4
32	U10-16	103-4	I	D12	Counter Out - bit 12
33	U9-15	102-5	I	D5	Counter Out - bit 5
34	U10-15	103-5	I	D13	Counter Out - bit 13
35	U9-14	102-6	I	D6	Counter Out - bit 6
36	U10-14	103-6	I	D14	Counter Out - bit 14
37	U9-13	102-7	I	D7	Counter Out - bit 7
38	U10-13	103-7	I	D15	Counter Out - bit 15
39	U11-19	104-1	I	D17	Counter Out - bit 17
40	U11-16	104-4	I	D20	Counter Out - bit 20
41	U11-15	104-5	I	D21	Counter Out - bit 21

(continued next page)

(continued from previous page)

42	U11-20	104-0	I	D16	Counter Out - bit 16
43	DGND	-	-	NC	not connected
44	Vcc	-	-	NC	not connected
45	nc	-	-	-	not connected
46	nc	-	-	-	not connected
47	nc	-	-	-	not connected
48	nc	-	-	-	not connected
49	nc	-	-	-	not connected
50	nc	-	-	-	not connected

Connector J3 - 1x9 Pins - Serial Channel 0, RS-232 I/O

<u>Pin</u>	<u>Chip</u>	<u>Pin</u>	<u>In/Out</u>	<u>Signal</u>
1	nc	-	-	not connected
2	U17	1	in	Receive Data (RX)
3	U16	3	out	Transmit Data (TX)
4	U17	10	in	Data Carrier Detect (DCD)
5	DGND	-	-	Digital Ground
6	nc	-	-	no connected
7	U16	6	out	Ready to Send (RTS)
8	U17	4	in	Clear to Send (CTS)
9	nc	-	-	not connected

Connector J4 - 1x6 Pins - Analog Outputs

<u>Pin</u>	<u>Chip - Pin</u>	<u>Signal</u>	<u>Description</u>
1	AGND	AGND	
2	U20-20	D/A1	D-to-A Channel 1 Output - PMT temperature set
3	DGND	DGND	
4	AGND	AGND	
5	U21-20	D/A2	D-to-A Channel 2 Output - Filter temperature set
6	DGND	DGND	

Connector J5 - 1x15 - Differential Analog Inputs

<u>Pin</u>	<u>Chip -Pin</u>	<u>Signal</u>	<u>Description</u>
1	U6-5	SIGNAL	A-to-D Channel 0 - Non-Inverting - PMT preamp out
2	AGND	nc	not connected
3	U6-14	GND A	A-to-D Channel 0 - Inverting
4	AGND	nc	not connected
5	U6-6	TEMPPMT	A-to-D Channel 1 - Non-Inverting - PMT temperature
6	AGND	nc	not connected
7	U6-13	GND A	A-to-D Channel 1 - Inverting
8	AGND	nc	not connected
9	U6-7	TEMPFILT	A-to-D Channel 2 - Non-Inverting - Filter temperature
10	AGND	nc	not connected
11	6-12	GND A	A-to-D Channel 2 - Inverting
12	AGND	nc	not connected
13	U6-8		A-to-D Channel 3 - Non-Inverting
14	AGND	nc	not connected
15	U6-11		A-to-D Channel 3 - Inverting

Connector J6 - 1x7 Pins - Power Input

<u>Pin</u>	<u>Supply</u>	<u>Signal</u>
1	+5 VDC	VCC
2	DGND	GND D
3	nc	not connected
4	+15 VDC	+15V
5	AGND	GND A
6	nc	not connected
7	-15 VDC	-15V

Jumper settings on SBC

<u>Jumper</u>	<u>Pins to connect together</u>	
SW1	1-2	4-5
SW2	2-3	5-6
SW3	1-2	4-5
SW4	1-2	4-5
SW5	1-2	4-5
SW6	NOT USED	
SW7	1-2	4-5
SW8	NOT USED	
SW9	1-2	
SW10	1-2	
SW11	1-2	
SW12	1-2	

Appendix D

SSP-7 WIRING DIAGRAM

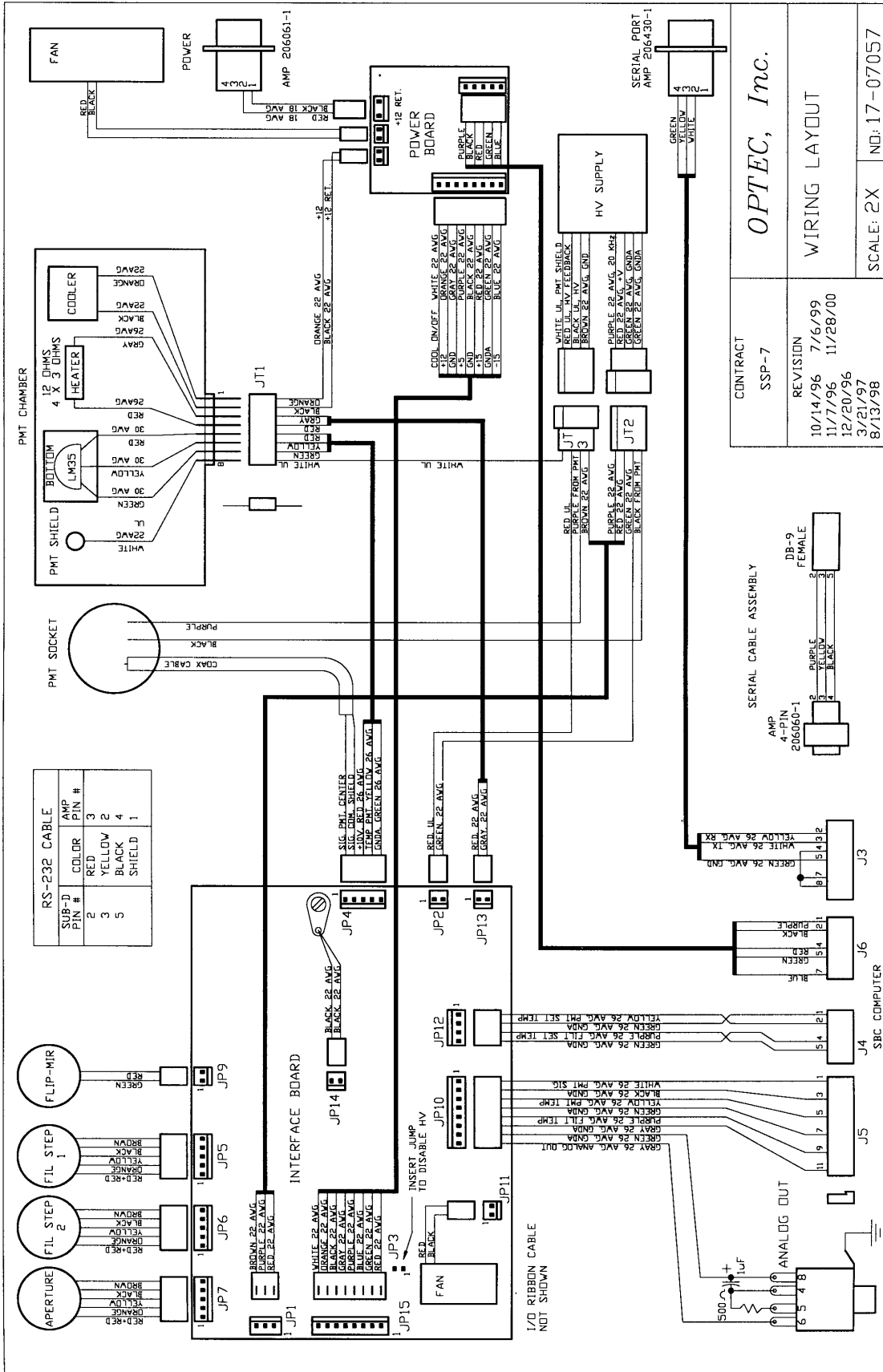

CONTRACT	SSP-7
REVISION	10/14/96 11/7/96 12/20/96 3/21/97 8/13/98
REVISION	7/6/99 11/28/00
SCALE:	2X
NO.:	17-07057

OPTEC, Inc.

WIRING LAYOUT

Appendix E

INTERFACE BOARD COMPONENT DIAGRAM

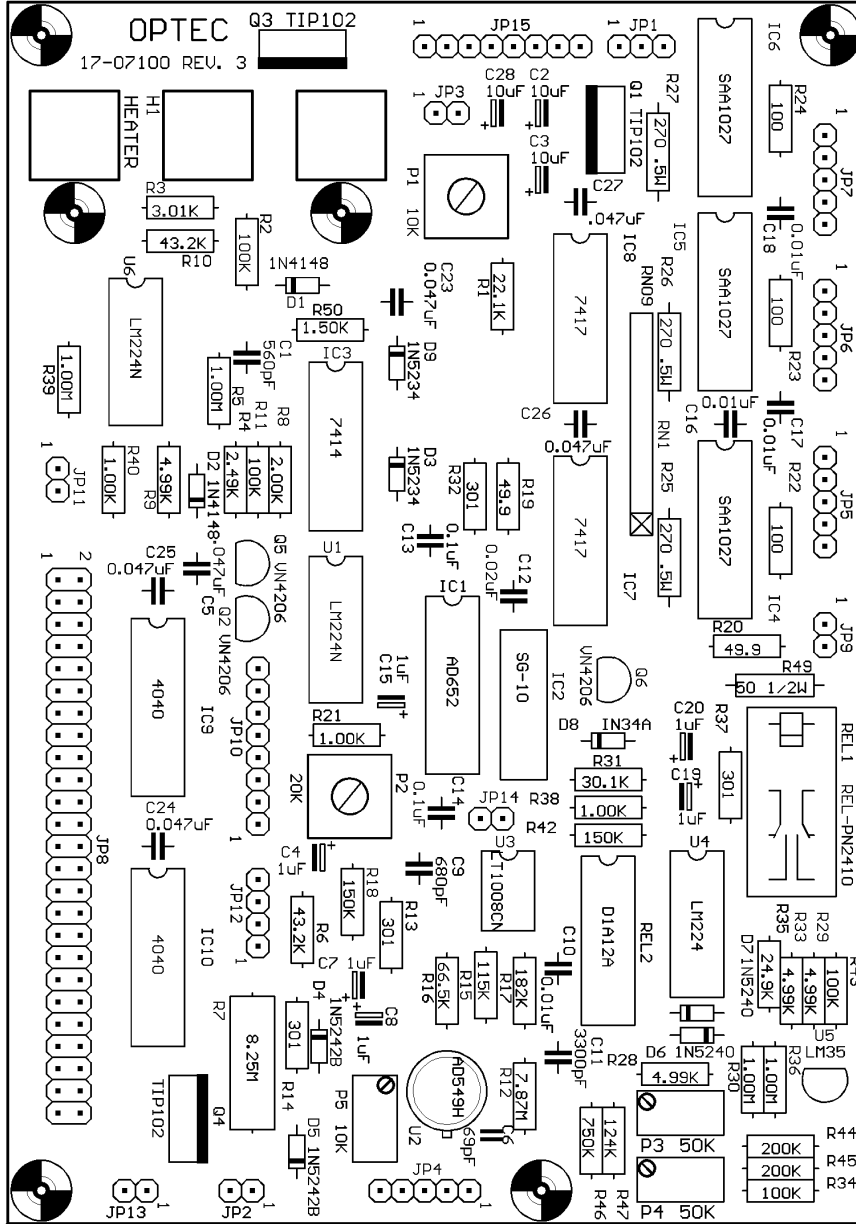

Appendix F

INTERFACE BOARD CIRCUIT DIAGRAM

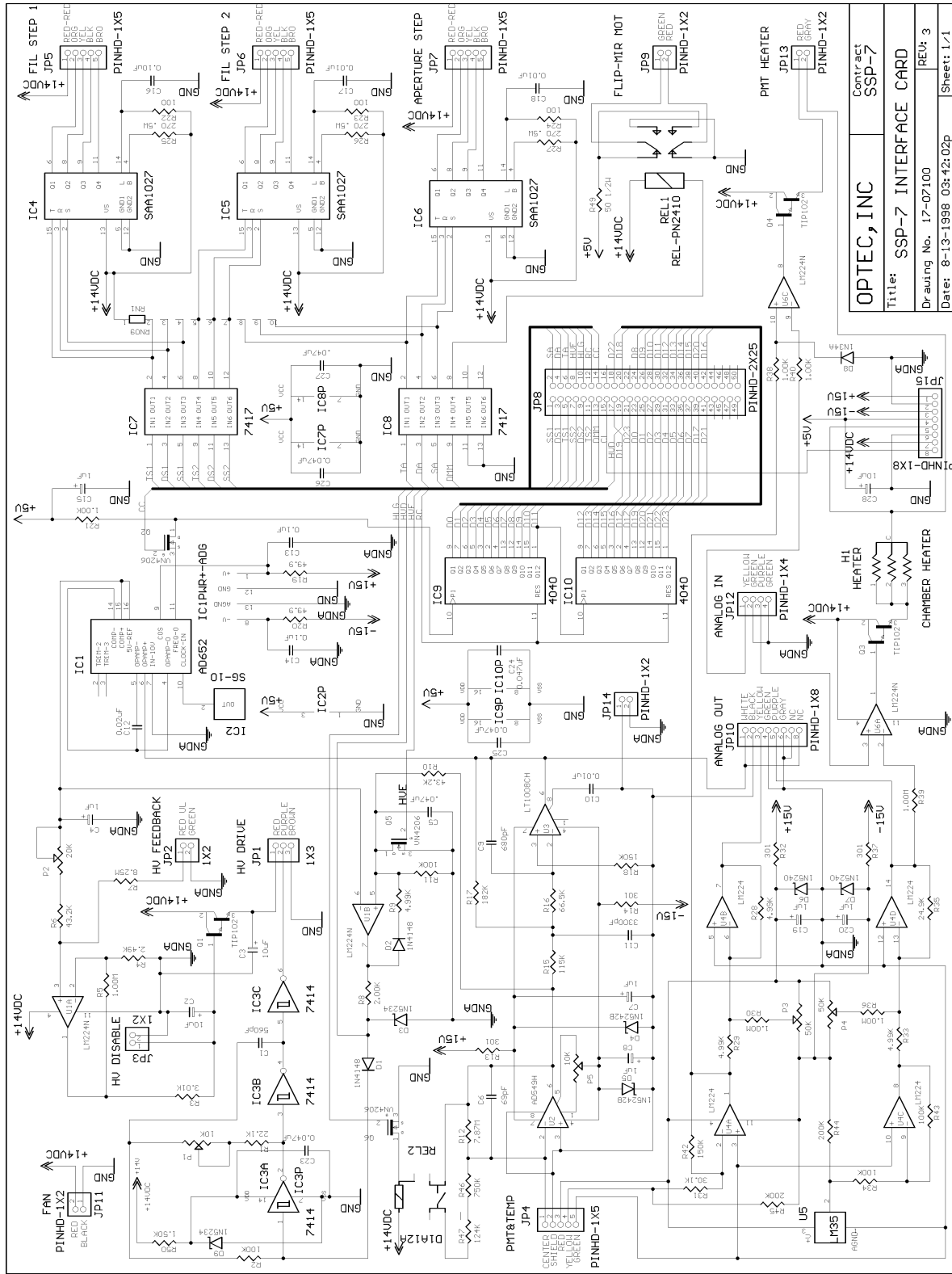

OPTEC, INC
 Contract
SSP-7
 Title: **SSP-7 INTERFACE CARD**
 Drawing No. 17-07100
 Date: 8-13-1998 03:42:02P
 REV: 3
 Sheet: 1/1

Appendix G

HAMAMATSU R4457 PMT DATA SHEET

PHOTOMULTIPLIER TUBE R4457

Figure 1: Typical Spectral Response

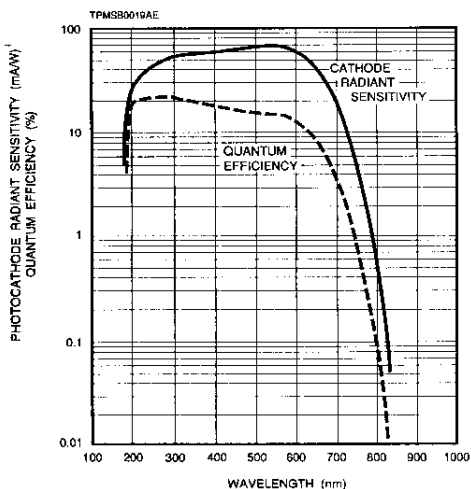

Figure 2: Anode sensitivity and Amplification

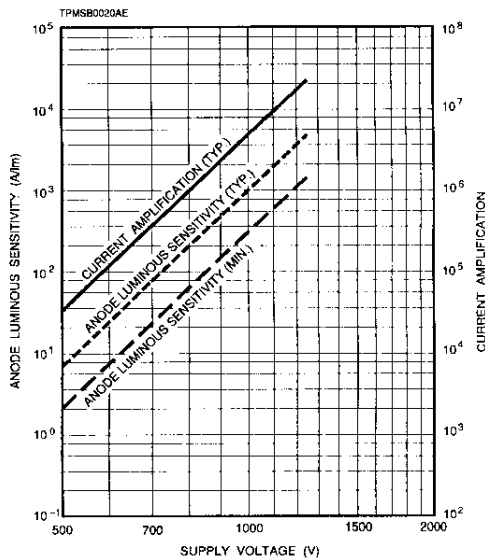
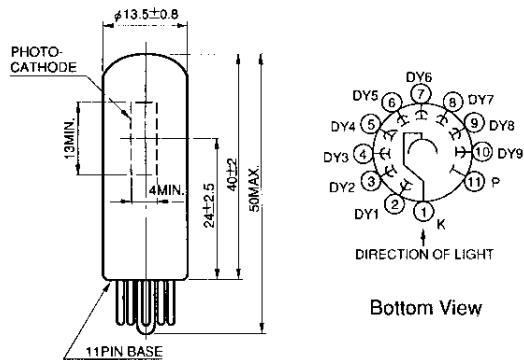

Figure 3: Dimensional Outline and Basing Diagram (Unit:mm)



TPMSA0004AE

HAMAMATSU

HAMAMATSU PHOTONICS K.K., Electron Tube Center

314-5, Shimokanzo, Toyooka-village, Iwata-gun, Shizuoka-ken, 438-01 Japan, Telephone:0539-62-5248, Fax:0539-62-2205, Telex:4289-625

U.S.A.: Hamamatsu Corporation:360 Foothill Road,P.O.Box 6910, Bridgewater, N.J. 08807-0910, Telephone 908-231-0960, Fax:908-231-1539

Germany: Hamamatsu Photonics Deutschland GmbH:Arzbergerstr. 10, D-8036 Harrsching am Ammersee, Telephone:49-8152-375 0, Fax:49-8152-2656, Telex:527731

France: Hamamatsu Photonics France:2 A. Citytech-BT 523, 3, Allée du Cdt-Mouchotte, Paray-Vieille Poste, 91781 Wissous Cedex, Telephone:33-(1)49 75 56 80, Fax:33-(1)49 75 56 87, Telex:3PF262082F

United Kingdom: Hamamatsu Photonics UK Limited: Lough Point, 2 Gladbeck Way, Windmill Hill, Enfield, Middlesex EN2 7JA, England, Telephone 44-81-367-3560, Fax:44-81-367-6384, Telex:927817

North Europe: Hamamatsu Photonics Norden AB: Kanalvägen 20 S-194 81 Upplands Väsby, Sweden, Telephone:46-760-32180, Fax:46 760-94567

Italy: Hamamatsu Photonics Italia S.R.L.: Via Monte Grappa 30, 20020 Aresè, Milano, Telephone:39-(2)935 81 733, Fax:39-(2)935 81 741

Cat. No. TPMS1005E0
JUL 91 NB
Printed in Japan (500)