

FT 100S
Installation and Operation

UDS
5000 Bradford Drive
Huntsville, AL 35805-1993
(205) 430-8000

Doc. 6 496 5046 03 014
May 1993
©1993 UDS

COPYRIGHT

Copyright 1993© by Universal Data Systems, Inc. (UDS), a subsidiary of Motorola Inc. (Information Systems Group).

Published by UDS, who reserves the right to make improvements in the products described in this manual as well as to revise this publication at any time and without notice to any person of such revision or change.

All rights reserved. No part of this publication may be reproduced, transcribed, stored in an electronic retrieval system, translated into any language or computer language, or be transmitted in any form whatsoever without the prior written consent of the publisher. For additional information contact

UDS
5000 Bradford Drive
Huntsville, Alabama 35805-1993
(205) 430-8000

TRADEMARKS

UDS[®] is a registered trademark of Universal Data Systems, Inc.
IBM[®] is a registered trademark of International Business Machines Corporation.
Sync-Up[™] is a trademark of UDS.
LocalView[™] is a trademark of UDS.

NOTICE

All titles, versions, trademarks, claims of compatibility, etc., of hardware and software products mentioned herein are the sole property and responsibility of the respective vendors. UDS makes no endorsement of any particular product for any purpose, nor claims responsibility for its operation and accuracy.

UPDATES

Updates to the products and the manual are obtainable at participating UDS dealers and distributors, or directly from UDS on the same terms and conditions as those offered by UDS to its registered customers as verified by the completion and return of the registration form to UDS.

FCC REQUIREMENTS

This equipment complies with Part 68 of FCC Rules. Please note the following:

- When you order service, the telephone company needs to know:

A. The Facility Interface Code:

04DU9-BN (1.544 Mbps superframe format (SF) without line power)
04DU9-DN (1.544 Mbps SF and B8ZS without line power)
04DU9-1KN (1.544 Mbps ANSI ESF without line power)
04DU9-1SN (1.544 Mbps ANSI ESF and B8ZS without line power)

B. The Service Order Code: 6.0N

A signal power affidavit will be required to guarantee encoded analog content and billing protection unless this unit is used in combination with an XD type device or no encoded analog signals and billing information are transmitted. A SAMPLE AFFIDAVIT is attached. For most uses, the second box is appropriate.

C. The USOC Jack Required: RJ48C

In addition, if requested, please inform the telephone company of the make, model number and FCC registration number, which are on the label.

The telephone company may change technical operations or procedures affecting your equipment. You will be notified of changes in advance to give you ample time to maintain uninterrupted telephone service.

If you experience trouble with this telephone equipment, please contact

UDS
5000 Bradford Drive
Huntsville, Alabama 35805-1993
Telephone: (205) 430-8000

for information on obtaining service or repairs. The telephone company may ask that you disconnect this equipment from the network until the problem has been resolved. If your equipment continues to disrupt the network the telephone company may temporarily disconnect service. If this occurs you will be informed of your right to file a complaint with the FCC.

WARNING

This equipment uses, generates, and can radiate radio frequency energy interfering with radio communications if not installed and used in accordance with the instruction manual. It has been tested and complies with the limits for a Class A computing device according to FCC Rules, Part 15. Operation of this equipment in a residential area may cause interference. If it does, you must correct the cause of the interference. Shielded cables may be necessary with this unit to ensure compliance with the Class A limits.

Changes or modifications to this unit not expressly approved by the party responsible for compliance could void the user's authority to operate the equipment.

AFFIDAVIT FOR CONNECTING CUSTOMER PREMISES EQUIPMENT TO 1.544 Mbps AND / OR SUBRATE DIGITAL SERVICES

For work to be performed in the certified territory of _____
TELCO NAME

State of _____ County of _____

I, _____, _____
NAME BUSINESS ADDRESS

_____ representing _____
NAME OF CUSTOMER

_____ being duly sworn, state:
TELEPHONE NUMBER

I have responsibility for the operation and maintenance of the terminal equipment to be connected to 1.544 Mbps and / or _____ Subrate digital services. The terminal equipment to be connected complies with Part 68 of the Commissions rules except for the encoded analog content and billing protection specifications. With respect to encoded analog content and billing protection:

- I attest that all operations associated with the establishment, maintenance and adjustment of the digital CPE with respect to encoded analog content and encoded billing information continuously complies with Part 68 of the FCC Rules and Regulations.
- The digital CPE does not transmit digital signals containing encoded analog content or billing information which is intended to be decoded within the telecommunications network.
- The encoded analog and billing protection is factory set and is not under the control of the customer.

I attest that the operator(s) maintainer(s) of the digital CPE responsible for the establishment, maintenance and adjustment of the encoded analog content and billing information has (have) been trained to perform these functions by successfully completing one of the following. Check the appropriate ones:

- _ a. A training course provided by the manufacturer / grantee of the equipment used to encode analog signals; or
- _ b. A training course provided by the customer or authorized representative, using training materials and instructions provided by the manufacturer / grantee of the equipment used to encode analog signals; or

- _ c. An independent training course (e. g., trade school or technical institution) recognized by the manufacturer / grantee of the equipment used to encode analog signals; or
- _ d. In lieu of the proceeding training requirements, the operator(s) maintainer(s) is (are) under the control of a supervisor trained in accordance with _____ above.
CIRCLE ONE

I agree to provide _____ with proper documentation to demonstrate
TELCO NAME
compliance with the information as provided in the proceeding paragraph, if so requested.

SIGNATURE

TITLE

DATE

Subscribed and Sworn to before me
this ____ day of _____, 19__.

NOTARY PUBLIC

My Commission expires:

SPECIAL REQUIREMENTS FOR CANADA

Certain requirements exist for data communication products manufactured for use in Canada. Principle among these requirements is the application of the DOC stamp as described below. However, certain data communication products do not require the DOC stamp nor adherence to DOC requirements. If this is the case the DOC stamp will not be affixed to the rear panel of standalone units nor packaged with units designed for insertion in user equipment.

DEPARTMENT OF COMMUNICATIONS (DOC) REQUIREMENTS

DOC stamps are affixed to the rear of each standalone unit sold in Canada. Card units which are installed in the user's equipment are shipped with a stamp included. The user should place the stamp on the outside of his equipment as close as possible to the telephone line connector. This stamp has the certification number for that particular unit. The numbers are different for each model.

The Canadian Department of Communications label identifies certified equipment. This certification means that the equipment meets certain telecommunications network protective, operational, and safety requirements. The Department does not guarantee the equipment will operate to the user's satisfaction.

Before installing this equipment, users should ensure that it is permissible to be connected to the facilities of the local telecommunications company. The equipment must also be installed using an acceptable method of connection. In some cases, the company's inside wiring associated with a single line individual service may be extended by means of a certified connector assembly (telephone extension cord). The customer should be aware that compliance with the above conditions may not prevent degradation of service in some situations.

Repairs to certified equipment should be made by an authorized Canadian maintenance facility designated by the supplier. Any repairs or alterations made by the user to this equipment, or equipment malfunctions, may give the telecommunications company cause to request the user to disconnect the equipment. For their own protection users should ensure that the electrical ground connections of the power utility, telephone lines and internal metallic water pipe system, if present, are connected together. This precaution may be particularly important in rural areas.

CAUTION

Users should not attempt to make installation connections themselves, but should contact the appropriate electric inspection authority or electrician.

LOAD NUMBER

The Load Number (LN) assigned to each terminal device denotes the percentage of the total load to be connected to a telephone loop which is used by the device to prevent overloading. The termination on a loop may consist of any combination of devices subject only to the requirement that the total of the Load Numbers of all the devices does not exceed 100.

CANADIAN EMISSION REQUIREMENTS

This digital apparatus does not exceed the Class A limits for radio noise emissions from digital apparatus set out in the Radio Interference Regulations of the Canadian Department of Communications.

Le présent appareil numérique n'émet pas de bruits radioélectriques dépassant les limites applicables aux appareils numériques de la class A prescrites dans le Règlement sur le brouillage radioélectrique édicté par le ministère des Communications du Canada.

PREFACE	This manual is written for users of the UDS FT 100S. Please read the appropriate chapters before installation, changing any option, or operating the unit. This manual includes the following:
Chapter 1	Introduction - Contains introductory information;
Chapter 2	Installation - Contains instructions for mechanical and electrical installation of the unit;
Chapter 3	Hardware Configuration - Describes strap or switch option selection;
Chapter 4	Front Panel Option Selection - Describes options to be selected via LCD and pushbuttons;
Chapter 5	Operation - Describes operational procedures;
Chapter 6	Control Port Operation - Describes command access and modification to the unit via pin signals on the connector to the controlling terminal;
Chapter 7	Maintenance - Contains maintenance information;
Appendix A	Specifications;
Appendix B	Control Port Command Quick Reference;
Appendix C	Abbreviations and Acronyms.
Index	
Toll Free Numbers	
Warranty	
Warranty Card	

STATEMENT OF APPLICATION

This manual supports both the standalone and shelf mount units. Operation and function of either unit is identical. Where necessary, this manual provides detailed information in support of the standalone unit. Detailed information in support of the shelf mount unit can be found in the shelf installation and operation manual.

Table of Contents

FT 100S

Chapter 1	GENERAL 1-1
Introduction	FUNCTIONAL DESCRIPTION 1-1
	PHYSICAL DESCRIPTION 1-1
	FEATURES 1-2
Chapter 2	GENERAL 2-1
Installation	RECEIPT INSPECTION 2-1
	SITE PREPARATION 2-1
	CONNECTIONS 2-3
	FT 100S to Network 2-3
	FT 100S to Remote Control Device 2-3
	FT 100S to DTE 2-4
	V.35 / RS-449 Adapter Installation 2-8
	POWER 2-8
Chapter 3	GENERAL 3-1
Hardware	COVER REMOVAL 3-1
Configuration	CHANGING OPTION SETTINGS 3-2
	Grounding 3-4
	T1 NETWORK INTERFACE OPTIONS 3-4
	Network Receiver 3-5
	Network Transmit Line Build-out Switch S1 3-5
	DTE INTERFACE OPTIONS 3-6
	Installing an Interface Card 3-6
	Using a Conversion Adapter 3-7
Chapter 4	GENERAL 4-1
Front Panel	LCD MENUS 4-1
Option Selection	Using the Pushbuttons to Select Options 4-1
	Powerup Displays 4-5
	PORT STATUS DISPLAY MAIN MENU 1 4-6
	Line Status 4-6
	DTE Status 4-8
	DIAGNOSTIC OPTIONS MAIN MENU 2 4-9
	T1 TESTS 4-9
	T1 Local Loopback 4-10
	T1 Network Loopback 4-10

Chapter 4
continued

Remote CSU Loopback	4-13
Test In Progress	4-15
DTE PORT TESTS	4-15
DTE Port Local Terminal Loopback	4-16
DTE Port Remote Terminal Loopback	4-16
DTE Port Remote Loopback	4-19
DTE Port Test Pattern	4-23
Test In Progress	4-25
Bit Errors Display	4-25
Average Bit Error Rate Display	4-25
Elapsed Seconds Display	4-26
Restart Test Display	4-26
SELF TEST	4-26
DS0 MONITOR	4-28
PERFORMANCE HISTORY	4-29
% Error Free Seconds	4-30
Error Events	4-30
Timed Error Data	4-31
CONFIGURATION OPTIONS	
MAIN MENU 3	4-33
T1 LINE OPTIONS	4-33
T1 Framing	4-34
Line Code	4-34
Bit Stuffing	4-35
ANSI Error History	4-35
AT&T Error History	4-36
Timing	4-36
Line Loopback	4-37
Payload Loopback	4-38
Idle Code	4-38
Yellow Alarm	4-38
DTE PORT OPTIONS	4-39
V.35 or RS-530	4-39
Port Data Rate	4-40
DS0 Time Slot Assignment	4-41
Transmit Clock Source	4-42
Transmit Clock Polarity	4-43
Receive Clock Polarity	4-43
CTS Signal Operation	4-43
RLSD Signal Operation	4-44
DSR Signal Operation	4-44
TM Signal Operation	4-45
LL Signal Operation	4-45

Chapter 4 continued	RL Signal Operation	4-46
	Remote Loopback Operation	4-46
	CONTROL PORT OPTIONS	4-47
	Control Mode	4-48
	Baud Rate	4-49
	Local Echo	4-49
	SETTING A PASSWORD	4-50
	SET TIME AND DATE	4-51
Chapter 5 Operation	GENERAL	5-1
	CONTROLS AND INDICATOR	5-1
	LED DESCRIPTION	5-1
	TD	5-1
	RD	5-1
	CS	5-1
	LOS	5-1
	ALM	5-2
	TM	5-2
Chapter 6 Control Port Operation	GENERAL	6-1
	Using Control Port Commands	6-1
	CONNECTING TO A TERMINAL	6-9
	CONNECTING TO A MODEM	6-10
	CONNECTING TO LOCALVIEW	6-10
	MAIN MENU	6-11
	T1 LINE CONFIGURATION	6-13
	DTE PORT SUMMARY	6-15
	DTE PORT CONFIGURATION (V.35 or RS-530)	6-16
	CONTROL PORT CONFIGURATION	6-17
	TIME AND DATE	6-18
	T1 LINE TEST OPTIONS	6-18
	DTE PORT TESTS	6-19
	PERFORMANCE HISTORY	6-19
	Error Condition Categories	6-20
	Error Events	6-20
	Error Reporting Menus	6-22
	ESF Per AT&T Pub 54016	6-22
	ESF Per ANSI T1.403	6-22
	SF Error	6-23
Local Error History ANSI T1.403	6-23	
Remote Error History Per AT&T 54016	6-23	

Chapter 6	Carrier Performance History	6-24
continued	User Performance History	6-25
	REMOTE FT 100S CONFIGURATION	6-26
	Configuration Control CRC	6-26
	Remote Configuration Mode CRM	6-26
	Get Remote Configuration CR1	6-26
	Send Remote Configuration CR2	6-27
	Send Remote Unit ID CR3	6-27
	Send Remote Password CR4	6-27
	Send Remote Time and Date CR5	6-27
Chapter 7	GENERAL	7-1
Maintenance	FUSE	7-1
	MAINTENANCE	7-1
Appendix A	NETWORK INTERFACE	A-1
Specifications	NETWORK LOOPBACK CODES	A-1
	DTE INTERFACE	A-2
	CONTROL PORT	A-2
	POWER SUPPLY	A-2
	MECHANICAL	A-2
	ENVIRONMENTAL	A-3
Appendix B	B-1
Control Port Command		
Quick Reference		
Appendix C	GENERAL	C-1
Abbreviations and		
Acronyms		
Index		
Toll Free Numbers		
Warranty		
Warranty Card		

Illustrations FT 100S

		Figure	
Chapter 1 Introduction	1-1	Front Panel	1-4
	1-2	Rear Panel	1-4
Chapter 2 Installation	2-1	Installation	2-2
Chapter 3 Hardware Configuration	3-1	Cover Removal	3-2
	3-2	Strap, Switches, and Adapter Card Locations	3-3
	3-3	Strap Application	3-4
Chapter 4 Front Panel Option Selection	4-1	T1 Local Loopback	4-11
	4-2	T1 Network Loopback	4-12
	4-3	Remote CSU Loopback	4-14
	4-4	DTE Port Local Terminal Loopback .	4-17
	4-5	DTE Port Remote Terminal Loopback	4-18
	4-6	DTE Port Remote Loopback	4-20
	4-7	DTE Port Test Pattern Test	4-24
	4-8	FT100S Self Test Function	4-27
Chapter 6 Control Port Operation	6-1	Menu Flow Chart	6-2

Tables
FT 100S

Table

Chapter 2 Installation	2-1	Network Connector Pin Functions	2-3
	2-2	Control Port Connector Pin Functions	2-4
	2-3	RS-530 / RS-449 Pin Functions	2-5
	2-4	V.35 Pin Functions	2-6
Chapter 4 Front Panel Option Selection	4-1	Menu Options	4-2

Chapter 1 Introduction

GENERAL

The UDS FT 100S Fractional T1 CSU/DSU combines a single channel, fractional T1 DSU with a T1 ESF CSU. The unit interfaces customer premise data and voice equipment to a T1 transmission facility. High speed workstations, local and wide area networks, PBXs, facsimiles, and host computers are examples of customer equipment which may communicate over public or private T1 networks using the FT 100S.

FUNCTIONAL DESCRIPTION

The FT 100S receives serial data from the customer DTE and multiplexes it onto a 1.544 Mbps DS-1 signal. The DS-1 signal interfaces to the T1 network via an integral ESF CSU. The DTE ports enable data rates from 56 kbps to 1.536 Mbps. The unit complies with DTE interface standards for V.35 or RS-530, and supports all Fractional T1 applications.

Network management and configuration for the FT 100S are provided by several methods. An LCD front panel accesses all configuration and diagnostic options. An RS-232 rear panel interface labeled CONTROL allows configuring and testing the unit via terminal, computer, or remotely via modem. When the RM16M model is installed in the UDS LocalView shelf, configuration and diagnostics are accessible via the LocalView terminal. Operating parameters are stored in nonvolatile memory.

PHYSICAL DESCRIPTION

The FT 100S can be either a standalone desktop unit or the RM16M shelf mount model.

Three front panel pushbuttons, YES, NO, and HOME, enable user input. A front panel 32-character LCD allows menu driven user operation and real time unit status displays. DTE signal status can be monitored by six LEDs and the LCD on the front panel (Figure 1-1).

The rear panel (Figure 1-2) contains a power cord, fuse, an 8-pin RJ48C network interface connector, a 9-pin D-type interface connector for external control, and one 25-pin D-type DTE connectors. Since the FT 100S connects directly to the T1 network, it does not include an ON/OFF power switch.

FEATURES

- UDS Universal Data Shelf compatible
- Choice of several interfaces including:
 - V.35 synchronous or RS-530/RS-449 synchronous
- All standard data rates:
 - n x 56 kbps, n x 64 kbps (where n = number 1 to 24 of DS0 time slots-- 1.536 Mbps max)
- Fractional T1 compatible
- Uniform synthesized DTE transmit and receive clocks
- Flexible timing options
- Integral CSU
- B8ZS clear channel capability
- ESF or SF framing modes
- ESF diagnostics per AT&T 54016 and ANSI T1.403
- Built-in network and per channel loopback test capability
- Front panel LED status display for DTE ports

- Configuration and diagnostic options via
Front panel LCD,
RS-232 control port, or
UDS LocalView

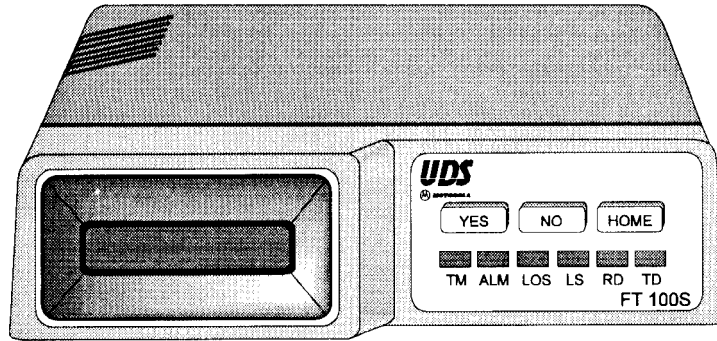

Figure 1-1
Front Panel

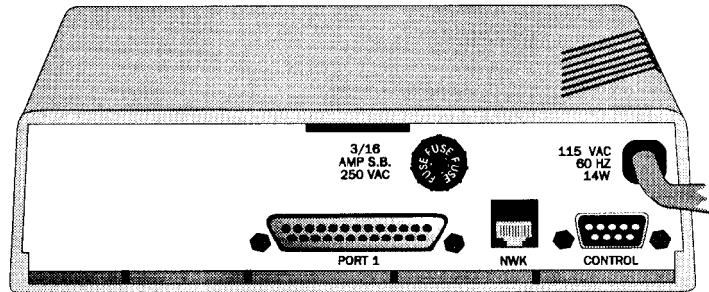

Figure 1-2
Rear Panel

Chapter 2 Installation

GENERAL

Note: When requesting T1 network service, personnel operating this equipment must complete the affidavit in the front of this manual.

This chapter provides installation information for the FT 100S. If changing hardware options to meet system requirements, refer to Chapter 3 before installation.

RECEIPT INSPECTION

After unpacking the equipment, check the contents against the packing list. Inspect the equipment carefully for damage that may have occurred in shipment. If there is damage or material shortage, contact the shipping agent and UDS for advice and assistance. UDS suggests retaining the shipping container and packing material for possible future shipment.

SITE PREPARATION

The installation area should be clean and free from extremes of temperature, humidity, and appreciable shock and vibration. Allow sufficient space at the rear of the unit for cable clearance and air flow.

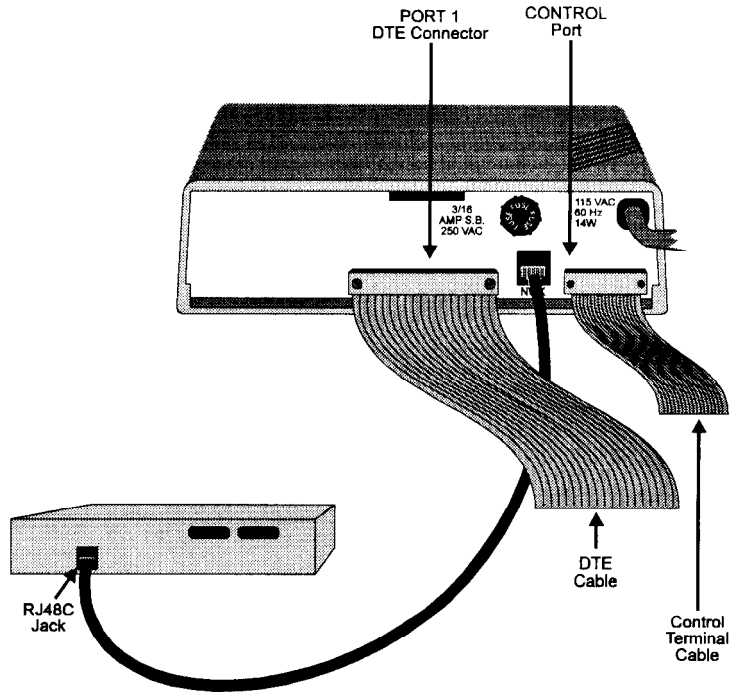

Figure 2-1
Installation

CONNECTIONS

Note: Before connecting the unit to the network or the DTE, determine whether the factory setting for Network Transmit LBO is set as required or must be changed. Refer to Chapter 3.

FT 100S to Network

Network T1 line connections are made through a standard 8-pin RJ48C jack labeled NWK on the rear panel. Table 2-1 list pin connections for the network connector.

Table 2-1
Network Connector Pin Functions

RJ48C Pin	Function
1	Network receive ring (R1)
2	Network receive tip (T1)
3	Not used
4	Network transmit (R)
5	Network transmit (T)
6	Not used
7, 8	Ground

To connect the unit to the network,

- insert one end of the supplied cable into the unit's NWK jack and
- insert the other end into the RJ48C on the T1 Network interface connector.

FT 100S to Remote Control Device

The 9-pin D-type male connector labeled CONTROL on the rear panel connects to the terminal that controls FT 100S operation, or to a modem connected to a remote terminal that controls the unit.

The interface is compatible with EIA RS-232 serial data operation and has pin functions like a DCE interface.

This is the same type of connector with the same pin connections as found on IBM PC/AT personal computers and compatibles so that standard cables can be used.

Pin connections for this interface are shown in Table 2-2.

Table 2-2
Control Port Connector Pin Functions

DB9 Pin	Function
1	Data carrier detect
2	Receive data
3	Transmit data
4	Data terminal ready
5	Ground
6	Data set ready
7	Request to send
8	Clear to send
9	Not used

To connect the unit to the network,

- insert one end of the cable into the unit's CONTROL port and
- insert the other end into the RS-232 connector on the controlling equipment.

FT 100S to DTE

The 25-pin D-type female connector on the rear panel connect to the DTE. Tables 2-3 and 2-4 show pin connections for the optional DTE connector available.

Table 2-3
RS-530 / RS-449 Pin Functions

RS-530 (DB25) Pin	RS-449 (DB37) Pin	Function
1	1	Protective ground
2	4	Transmit data A
3	6	Receive data A
4	7	Request to send A
5	9	Clear to send A
6	11	Data set ready A
7	19	Signal ground
8	13	Receive line signal detect A
9	26	Receive clock B
10	31	Receive line signal detect B
11	35	Ext transmit clock B
12	23	Transmit clock B
13	27	Clear to send B
14	22	Transmit data B
15	5	Transmit clock A
16	24	Receive data B
17	8	Receive clock A
18	10	Local loopback
19	25	Request to send B
20	12	Data terminal ready A
21	14	Remote loopback
22	29	Data set ready B
23	30	Data terminal ready B
24	17	Ext transmit clock A
25	18	Test mode

Table 2-4
V.35 Pin Functions

V.35 (DB25) Connector Pin	V.35 (34 pin V.35) Adapter Pin	Function
1	A	Protective ground
2	P	Transmit data A
3	R	Receive data A
4	C	Request to send
5	D	Clear to send
6	E	Data set ready
7	B	Signal ground
8	F	Receive line signal detect
9-12	--	Not used
13	AA/a	Transmit clock B
14	S	Transmit data B
15	Y	Transmit clock A
16	T	Receive data B
17	V	Receive clock A
18	J	Local loopback
19	X	Receive clock B
20	H	Data terminal ready
21	BB/b	Remote loopback
22	--	Not used
23	W	Ext transmit clock B
24	U	Ext transmit clock A
25	K	Test mode

To connect the unit to the DTE,

- Insert the DTE cable into the DTE connector on the unit.
- Insert the opposite end into the designated DTE.

Secure the screws to complete the connection.

**V.35 / RS-449
Adapter
Installation**

Optional adapters are available for converting the DTE connector to a 34-pin V.35 type connector or to a 37-pin RS-449 type connector. Contact your sales representative for ordering information. Pin connections for the V.35 and RS-449 adapters are listed in Tables 2-3 and 2-4.

POWER

Power is supplied through a 6-foot line cord with a grounded 3-wire plug. If chassis ground is available through the third prong of the plug, a separate ground wire is not required.

Chapter 3 Hardware Configuration

GENERAL

The FT 100S is factory configured to current industry standards. Because of the number of possible applications, the unit will require some option changes to fit a particular application.

This chapter describes the options that are configured with hardware on the printed circuit board. Hardware options are selected by two plug-on straps, a dip switch, and installing the interface adapter card. To access these options on the standalone unit, the cover must first be removed.

COVER REMOVAL

Warning: Do not remove the cover unless the power cord is unplugged.

- Place the unit on its side on a flat surface.
- Insert a medium size flat screwdriver blade in one of the bottom rear latch slots. Do not push the screwdriver but lightly pry the handle away from the unit as shown in Figure 3-1. This disengages the lock prong from the latch locks.
- Assist removal by pushing the cover from the chassis with your fingers on the unit rear edges. Repeat this procedure with the remaining latch slots.
- To replace the cover align the latch locks, rear guide grooves, and front lock tabs.
- Press the cover in place until the latch locks engage the lock prongs.

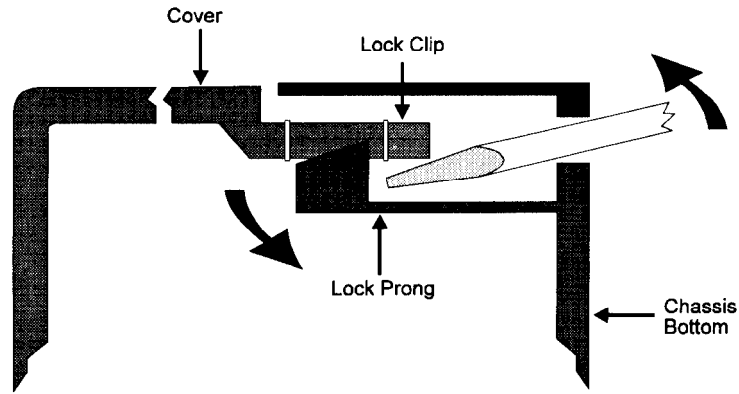

Figure 3-1
Cover Removal

**CHANGING
OPTION
SETTINGS**

Figure 3-2 shows the positions of the option straps, the dip switch, and the interface adapter card on the main printed circuit board.

Figure 3-3 shows a typical strap application.

To change a strap setting, lift the jumper strap off and insert it in the new position.

To change a switch position, use a pointed object to move the desired switch to ON or OFF.

Caution: Do not use a pen or pencil to change dip switches. Ink buildup or graphite debris could cause an electrical short.

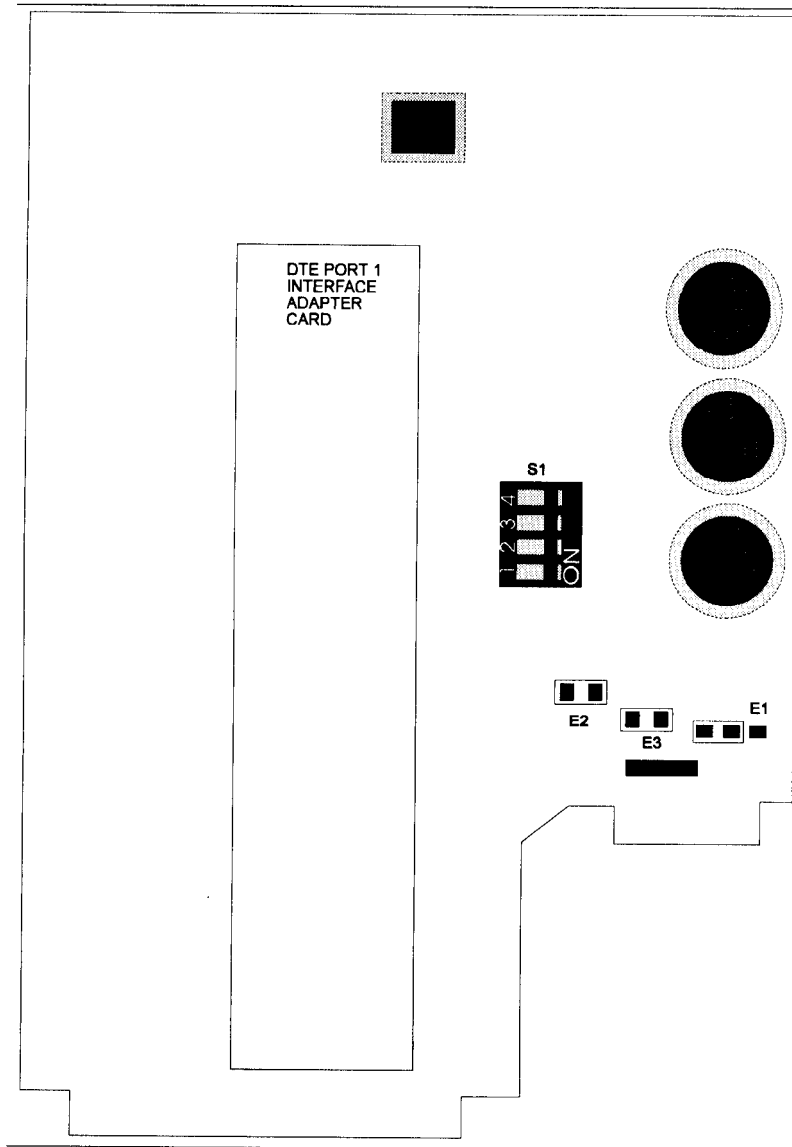

Figure 3-2
Strap, Switches, and Adapter Card Locations

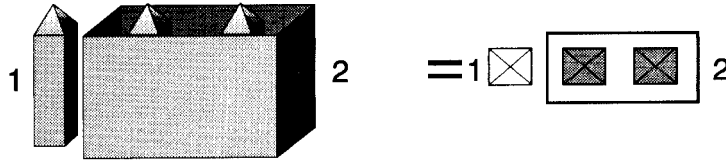

Figure 3-3
Strap Application

Grounding

Signal ground is normally connected to chassis ground. If interference exists, isolate signal ground from chassis ground by moving strap E1 to SIG.



Signal ground connected to chassis ground *
*factory setting

**T1 NETWORK
INTERFACE
OPTIONS**

The T1 network interface options are selected via dip switch S1 and straps E2 and E3. Figure 3-2 shows the locations of the switch and straps on the main printed circuit board.

Network Receiver Normally, the receiver range should be set for short distances when connected directly to a T1 line. This allows operation with a received signal range of +3.5 to -27.5 dB.

When operating with very long lines, set this option for long range. This allows the unit to operate with a received signal range of -4 to -34 dB.

The operating range is selected by installing the jumper on E2 and E3 as follows:

E2 short
E3 long

**Network Transmit
Line Build-out
Switch S1**

Line build-out (LBO) is an artificial line circuit that provides line attenuation. The amount of line build-out depends on the distance to the last T1 line repeater and is selected before installation. The telephone company providing the service determines the amount of LBO required.

Set dip switch S1 as required for 0, 7.5, or 15 dB.

Line Build-out	S1			
	1	2	3	4
0 dB LBO	On	On	Off	Off
7.5 dB LBO	Off	On	On	Off
15 dB LBO	Off	Off	On	On

**DTE INTERFACE
OPTIONS**

Several standard DTE interfaces are available.

Normally, the FT 100S is purchased with the required interface already installed. However, if application requirements change, the unit can be reconfigured.

The DTE interface type is selected by

- installing the appropriate adapter card onto the main printed circuit board and
- if required, installing an adapter for converting the DTE connector on the rear panel.

**Installing an
Interface Card**

The interface adapter card is located on the main printed circuit card as shown in Figure 3-2.

To remove a card, remove the stand off screws and carefully lift both ends of the card vertically to unplug the card.

Since the available interface adapter cards are used on various UDS products, they may contain switches and straps that must be set according to the product on which they're to be used. For the FT 100S, the settings are described in the table below. Option cards that were installed at the factory should already be configured properly.

V.35 Card		RS530/449 Card
#4563699 or 4563956	#4563507	#4563137
Switches 3, 4, 6 ON 1, 2, 5, 7, 8, OFF	Strapped for CHNL	Strapped for TM

To install a card,

- ensure the card is configured correctly
- align the connectors
- firmly press the adapter card down at both ends until the card fully seats and
- re-install stand off screws.

**Using a
Conversion
Adapter**

A V.35 or RS-449 connector conversion adapter can be attached to the rear panel DTE connector. These adapters convert the existing 25-pin D-type DTE connector to a 34-pin V.35 connector or 37-pin RS-449 connector.

Chapter 4 Front Panel Option Selection

GENERAL

FT 100S configuration options, operating status, and diagnostics can be observed or changed using the front panel pushbuttons with the LCD. The unit can also be controlled by the control port described in Chapter 6, or by the LocalView terminal when installed in the LocalView shelf.

LCD MENUS

Three main menus provide

- Port status displays
- Diagnostic options
- Configuration options

Each main menu is supported by submenus, items, and options.

While most menu items allow selecting different options, some only display the current status of a signal or function. These provide status monitoring for such features as receive signal frame synchronization and alarm reporting.

Table 4-1 lists all menus.

Using the Pushbuttons to Select Options

Generally, pressing NO scrolls vertically down the columns in Table 4-1 and pressing YES advances horizontally across the columns. Pressing HOME returns to the submenu or main menu header.

If the pushbuttons are pressed and held, the FT 100S automatically scrolls through the menu at a rate of about 4 display advances per second.

Table 4-1
Menu Options

<i>powerup display:</i>		(FT 100S) VERSION #.##		
<i>main display:</i>		(FT 100S) T1 ESF CSU/DSU		
MAIN MENU		SUBMENU	SUBMENU ITEM	OPTION
M A I N 1	Port Status Display?	Line Status:	Mode / Line Code / Framing / Receive Status	
		Port 1 Status	Mode / Interface / Data Rate	
M A I N 2	Diagnostic Options	T1 Tests?	T1 Local Loopback?	YES / NO
			T1 Network Loopback?	YES / NO
			Remote CSU Loopback?	YES / NO
		DTE Port Tests?	Local Terminal Loopback?	YES / NO
			Remote Terminal Loopback?	YES / NO
			Remote Loopback?	YES / NO
			Remote Loopback with Test Pattern?	YES / NO
			Test Pattern Test?	YES / NO
		Monitor DS0 Display	Channel Data ## nnnnnnn	channels 1-24
		Performance History Display?	Error Free Seconds?	nn% (0-100)
			ESF Error Count:	nn (0-65565)
			24 Hours Total?	ES / BES / SES / UAS / LOFC /
			15 Minute Interval Data?	LCVS (1-900 each)

Table 4-1, continued
Menu Options

MAIN MENU	SUBMENU	SUBMENU ITEM	OPTION	
M A I N 3	Configuration Options?	T1 Line Options?	Framing	SF / ESF *
		Line Code	AMI * / B8ZS	
		ESF (PRM) Transmission	Enable Disable *	
		ESF (AT&T) Mode	Enable Disable *	
		Timing	Loop * / Internal / Port 1 / Port 2 / External (Port 2)	
		Line LB	Enable / Disable *	
		Payload LB	Enable / Disable *	
		Idle Code	FF * / 7F	
		Yellow Alarm	Enable * / Disable	
		DTE Port Options? (V.35 or RS-530 interface card)	Select # of Time Slots	0 - 24 *
			Select Rate Multiple	56K bps 64K bps *
			Select Time Slots	Alternating Contiguous *
			Select Starting Time Slot	1 * - 24
			Transmit Clock Source	Internal * External
	Transmit Clock Polarity		Normal * Inverted	
	Receive Clock Polarity	Normal * Inverted		
	CTS Mode	Normal * Forced On		
	RLSD Mode	Normal * Forced On		
	DSR Mode	Normal * Forced On		
	TM Mode	Normal * Forced Off		

* factory default settings

Table 4-1, continued
Menu Options

MAIN MENU		SUBMENU	SUBMENU ITEM	OPTION
M A I N 3 C O N T.	Configuration Options? Cont.	DTE Port Options? Cont. (V.35 or RS-530 interface card)	LL Mode	Enable / Disable *
			RL Mode	Enable / Disable *
			Remotely Activated Loopback	Enable * Disable
		Control Port Options?	Mode	Terminal * Computer LocalView
			Baud Rate	300 600 1200 2400 4800 9600 19200 *
			Local Echo	On * / Off
			Status	Lock / Unlock *
			Set Time?	Set time
			Set Date?	Set data

* factory default settings

Options are selected by pressing the YES/NO push-buttons in answer to prompts or questions.

In some cases, option fields on the LCD blink.

If this occurs and the displayed selection for the option should be changed, press NO to display another selection.

If the displayed selection is the setting required, press YES to select it and advance to the next option field or submenu.

Powerup Displays

On powerup, the FT 100S displays a sign-on message for 2 seconds which includes the software version number:

```
FT 100S
VERSION x.xx
```

During this time, the unit performs a self diagnostic test.

If the test fails, a message appears describing the malfunction.

If the unit passes the test, the product name displays:

```
FT 100S
T1 ESF CSU/DSU
```

PUSHBUTTON ACTION:

YES- None

NO- Advances to PORT STATUS DISPLAY?

HOME- Redisplays software version message.

**PORT STATUS
 DISPLAY
 MAIN MENU 1**

**Port Status
 Display?**

This menu contains display-only messages for monitoring the status of the line and DTE ports.

PUSHBUTTON ACTION:

- YES- Advances to LINE STATUS: display
- NO- Advances to DIAGNOSTIC OPTIONS? menu
- HOME- Returns to the FT 100S T1 CSU/DSU main menu header

Line Status

Line Status:
Mode LC Fram Rec Status

The line status display indicates the present status of the FT 100S / T1 network interface. The display includes the four status fields shown in the following table.

Status Field	Mode	Line Code	Framing	Receive Status
Possible Status	NORM	AMI	SF	SYNC
	LLB	B8Z	Fe	LOS
	NLB			AIS
	RLU			YEL
	PLB			
	RCLB			

The Mode field displays the present operating mode of the T1 network interface. Mode status indications are

- NORM Normal operation
- LLB Local loopback
- NLB Network loopback
- RLU Remote loop up
- PLB Payload loopback
- RCLB Remote CSU loopback

Port Status Main Menu 1, Cont.

The Line Code field displays the T1 line code option selected during configuration. To change the selection, refer to Configuration Options later in this chapter. Indications are

- AMI Alternate mark inversion
- B8Z Binary 8-zero substitution

The Framing field displays the T1 framing option selected during configuration. Refer to Configuration Options later in this chapter. The framing status indications are

- SF Superframe (D4) framing
- Fe Extended superframe (ESF) framing

The Receive Status field displays the status of the FT 100S T1 network receiver. The receive status indications are

- SYNC Frame synchronization is established.
- LOS Loss of synchronization
- AIS Alarm indication signal
(unframed all ones) is being received.
- YEL Yellow alarm signal is being received.

PUSHBUTTON ACTION:

- YES- None
- NO- Advances to Port 1 Status:
- HOME- Returns to PORT STATUS DISPLAY?
 menu

Port Status Main Menu 1, Cont.

DTE Status

Port 1 Status:		
Mode	Interface	Data Rate

This display indicates the selected DTE port status. The three fields of the display are

Status Field	Mode	Interface	Data Rate
Possible Status	NORM	V.35	56K - 1536K
	LTL	RS530	
	RTL		
	RL		
	RLTP		
	RAL		
	TP		

The Mode field displays the present operating mode of all FT 100S DTE port:

- NORM Normal operation
- LTL Local terminal loopback test
- RTL Remote terminal loopback test
- RL Remote loopback test
- RLTP Remote loopback w/test pattern
- RAL Remotely activated loopback test
- TP Test pattern test

The Interface field displays the DTE interface configuration that was selected during hardware configuration for the DTE port (Chapter 3).

The Data Rate field displays the selected data bit rate for the DTE port. Rate values can range from 56 kbps to 1,536 kbps. Refer to the Configuration Option Menu description in this chapter to change the data rate.

Port Status Main Menu 1, Cont.

PUSHBUTTON ACTION:

- YES- None
- NO- Advances to LINE STATUS
- HOME- Returns to PORT STATUS DISPLAY? menu

**DIAGNOSTIC
OPTIONS
MAIN MENU 2**

**Diagnostic
Options?**

This menu accesses the diagnostic tests, which are divided into four submenus:

- T1 tests
- DTE port tests
- DS0 monitor
- Performance history display

PUSHBUTTON ACTION:

- YES- Advances to T1 TESTS? submenu
- NO- Advances to CONFIGURATION OPTIONS? menu
- HOME- Returns to the FT 100S T1 CSU/DSU main menu header

T1 TESTS

T1 Tests?

The T1 line test modes include

- T1 Local Loopback
- T1 Network Loopback
- Remote CSU Loopback.

PUSHBUTTON ACTION:

- YES- Advances to T1 LOCAL LOOPBACK? test mode
- NO- Advances to DTE PORT TESTS? submenu
- HOME- Returns to DIAGNOSTICS OPTIONS? menu

**T1 Local
Loopback**

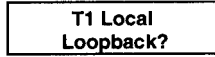

Figure 4-1 shows the unit in Local Loopback. This test loops the network T1 transmitter output to the receiver input at the network interface. Since the entire T1 data payload is looped back, the DTE port is also looped back. This allows the local DTE to test the local unit. The looped back T1 signal is also transmitted to the network to keep the network active.

All TM LEDs light to indicate a T1 test in progress. Other LEDs function normally.

PUSHBUTTON ACTION:

- YES- Enters Local Loopback; advances to T1 LOCAL IN PROGRESS - END?
- NO- Advances to next test mode T1 NETWORK LOOPBACK?
- HOME- Returns to T1 TESTS? submenu

**T1 Network
Loopback**

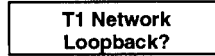

Figure 4-2 shows the unit in Network Loopback. The T1 network received signal is looped back to the network transmitter and also passed to the DTE port. The DTE port transmit signal is blocked. This allows testing the T1 network from a remote FT 100S, a remote CSU, or from the telephone company central office.

All TM LEDs light to indicate a T1 test in progress. Other LEDs function normally.

PUSHBUTTON ACTION:

- YES- Enters network loopback; advances to T1 NETWORK LOOP IN PROGRESS - END?
- NO- Advances to Remote CSU Loopback?
- HOME- Returns to T1 TESTS? submenu

Diagnostic Options Main Menu 2, Cont.

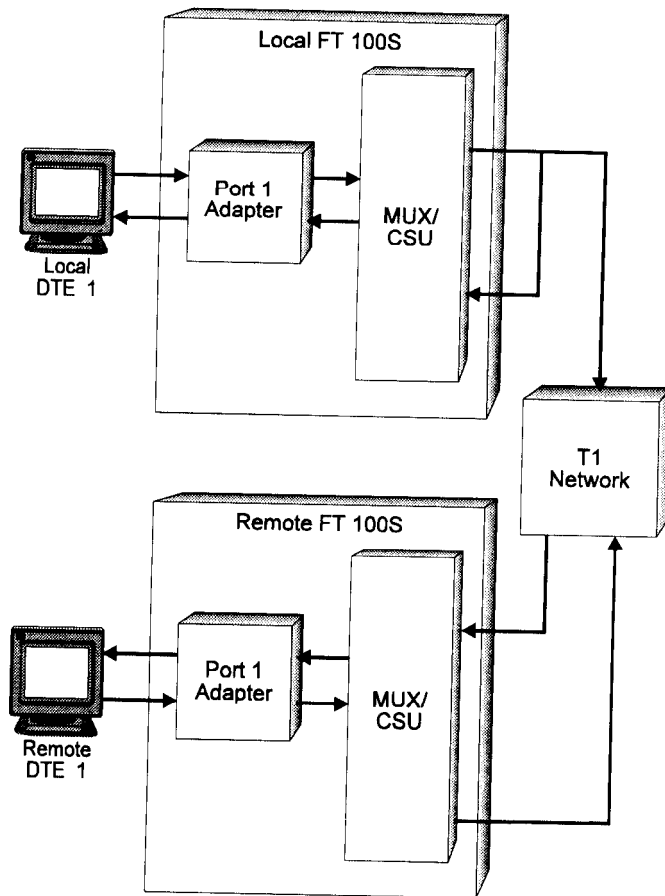

Figure 4-1
T1 Local Loopback

Diagnostic Options Main Menu 2, Cont.

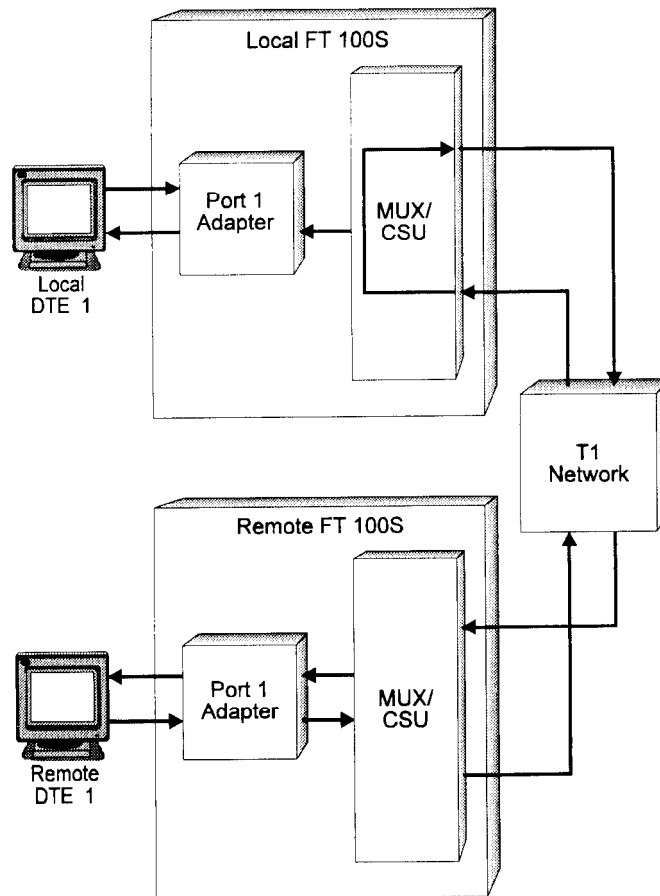

Figure 4-2
T1 Network Loopback

Diagnostic Options Main Menu 2, Cont.

**Remote CSU
Loopback**



Figure 4-3 shows the unit in Remote CSU Loopback. When initiated, the local FT 100S transmits a loop-up code causing the remote unit to enter Remotely Activated Network Loopback. The loop-up code is transmitted until the remote unit enters loopback. The local unit then resumes normal operation. The remote unit enters loopback after the loop-up code has been received for at least 4 seconds.

The FT 100S responds to the standard CSU inband loop codes and out-of-band ESF loop codes received on the FDL. When the loop-up code is detected, the unit initiates a T1 network loopback. The loopback is terminated when the loop-down code is received.

When Remote CSU Loopback is terminated, a loop-down code is transmitted causing the remote unit to return to normal operation.

The loop-up and loop-down codes are compatible with AT&T and ANSI inband loop codes. Therefore, the remote unit can be another FT 100S or a standard CSU device.

Loop-up set code -- repeating bit pattern 10000.
Loop-down reset code -- repeating bit pattern 100.

All TM LEDs light to indicate a T1 test is in progress. Other LEDs function normally.

PUSHBUTTON ACTION:

YES- Initiates Remote CSU loopback; advances to Remote CSU Loop in progress - End?

NO/

HOME- Returns to T1 Test? submenu

Diagnostic Options Main Menu 2, Cont.

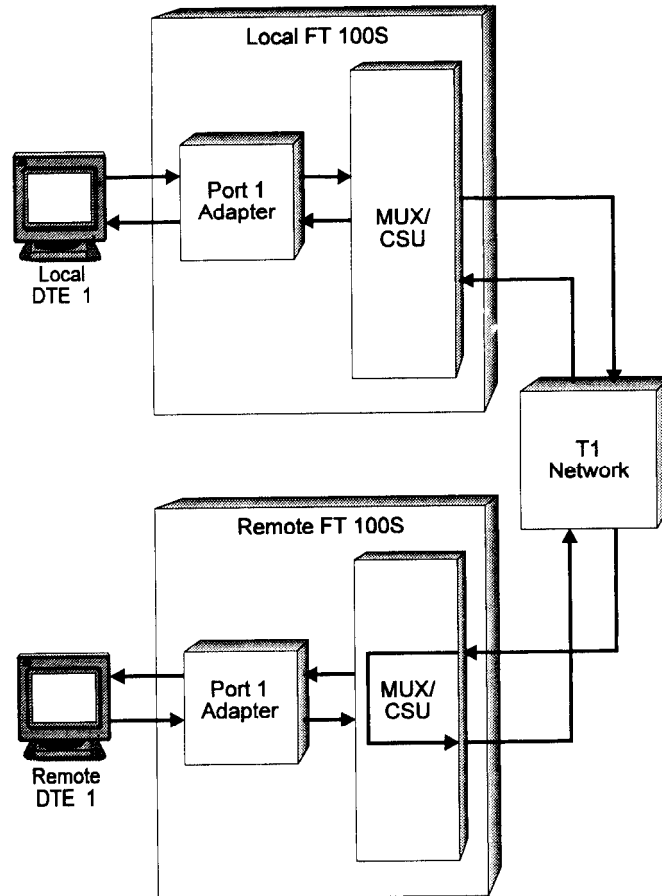

Figure 4-3
Remote CSU Loopback

Diagnostic Options Main Menu 2, Cont.

Test In Progress

**XXX
In Progress-End?**

This display indicates a test is in progress. *XXX* represents the particular test mode.

PUSHBUTTON ACTION:

- YES- Terminates the test
- NO- Advances to next test menu
- HOME- Returns to top of the present test menu

**DTE PORT
TESTS**

DTE Port Tests?

This submenu display accesses these DTE port test modes:

- Local Terminal Loopback
- Remote Terminal Loopback
- Remote Loopback
- Test Pattern

PUSHBUTTON ACTION:

- YES- Advances to the first test mode DTE LOCAL TERMINAL LOOPBACK?
- NO- Advances to MONITOR DS0 DISPLAY? submenu
- HOME- Returns to DIAGNOSTIC OPTIONS? menu

Diagnostic Options Main Menu 2, Cont.

**DTE Port Local
Terminal
Loopback**

**DTE Loc Term
Loopback?**

Figure 4-4 shows DTE port in Local Terminal Loopback. Transmit data from the DTE is looped back to the DTE received data line. This allows testing the FT 100S interface adapter card and the cabling to the DTE port from the DTE.

The TM LED lights to indicate a test in progress. Other LEDs function normally.

PUSHBUTTON ACTION:

- YES- Enters local terminal loopback; advances to LOC TERM IN PROGRESS-END
- NO- Advances to REM TERM LOOPBACK? test mode
- HOME- Returns to DTE PORT TESTS? submenu

**DTE Port Remote
Terminal
Loopback**

**DTE Rem Term
Loopback?**

Figure 4-5 shows the DTE port in Remote Terminal Loopback. Received data from the remote DTE is looped back to the remote DTE. The received data is also passed to the local DTE.

The TM LED lights to indicate a test in progress. Other LEDs function normally.

PUSHBUTTON ACTION:

- YES- Enters remote terminal loopback; advances to REM TERM LOOP IN PROGRESS-END?
- NO- Advances to REMOTE LOOPBACK? test mode
- HOME- Returns to DTE PORT TESTS? submenu

Diagnostic Options Main Menu 2, Cont.

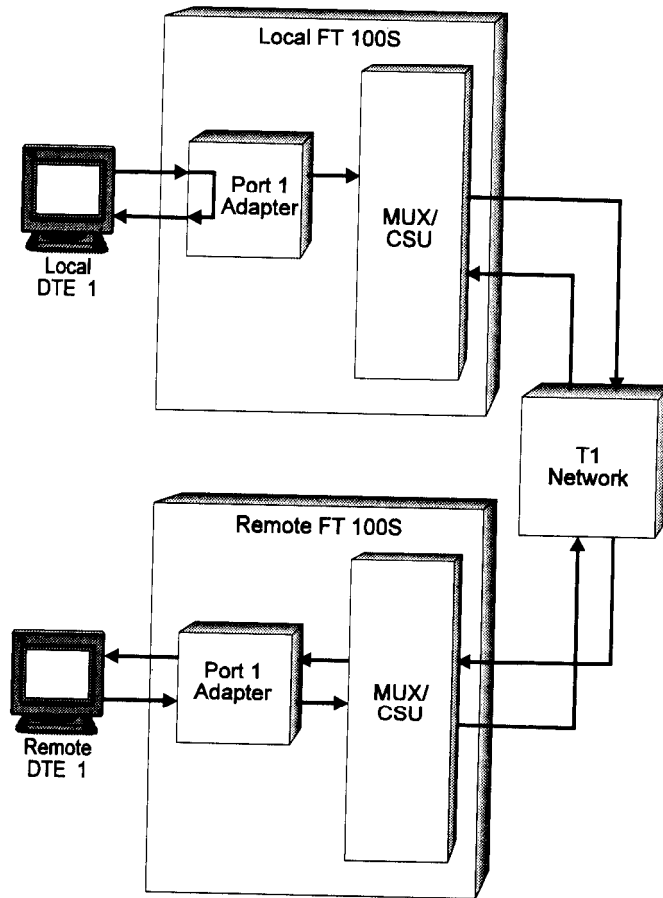

Figure 4-4
DTE Port Local Terminal Loopback

Diagnostic Options Main Menu 2, Cont.

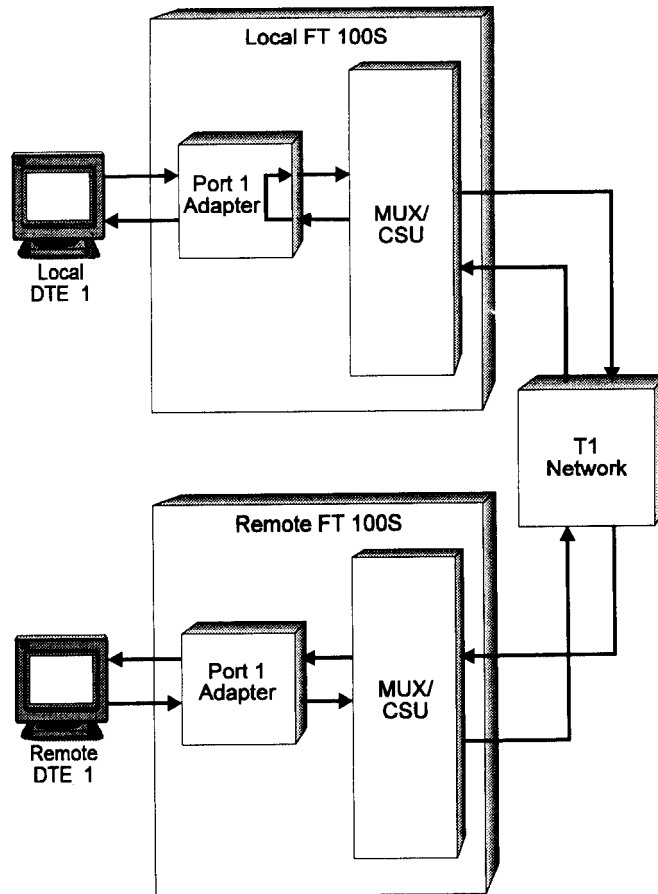

Figure 4-5
DTE Port Remote Terminal Loopback

Diagnostic Options Main Menu 2, Cont.

**DTE Port Remote
Loopback**



Figure 4-6 shows DTE port in Remote Loopback. The local FT 100S puts the DTE port on the remote FT 100S in remote terminal loopback by sending a (5 bit) repeating pattern (11110) transmitted inband for at least 5 seconds.

The loop pattern continues until the local FT 100S recognizes that the remote FT 100S is looped. As an option, the local DTE signal may be replaced by an internally generated test pattern.

The test pattern is transmitted to the remote FT 100S and monitored by the local FT 100S for errors indicated by an LCD message.

The TM LED lights to indicate a test in progress. On the remote FT 100S, the TM LED blinks to indicate a remotely activated test in progress. Other LEDs function normally.

PUSHBUTTON ACTION:

- YES- Enters remote loopback; advances to WITH TEST PATTERN?
- NO- Advances to TEST PAT TEST? mode
- HOME- Returns to DTE PORT TESTS? submenu

Diagnostic Options Main Menu 2, Cont.

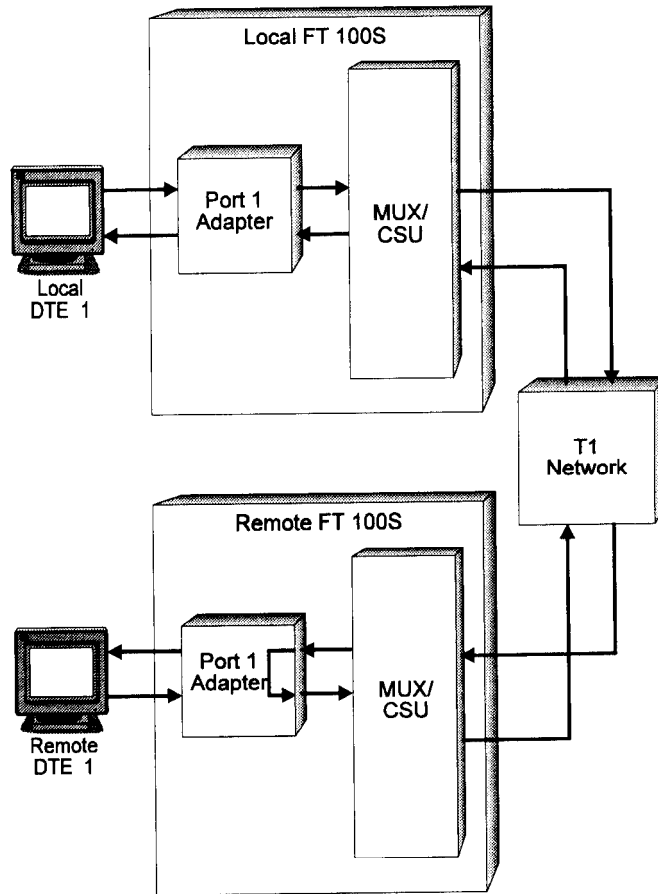

Figure 4-6
DTE Port Remote Loopback

Diagnostic Options Main Menu 2, Cont.

**With Test
Pattern?**

If a test pattern is selected with Remote Loopback, the local unit transmits a 511 test pattern and monitors the receive data signal for this test pattern. Error information is recorded and can be displayed (see Test Pattern Test).

PUSHBUTTON ACTION:

- YES- Sends a loop-up pattern to remote DSU with test pattern and advances to ATTEMPTING TO LOOP REMOTE DSU display
- NO- Sends loop-up pattern to remote DSU without test pattern and advances to ATTEMPTING TO LOOP REMOTE DSU display
- HOME- Returns to DTE PORT TESTS? submenu

**Attempting to
Loop Remote DSU**

The local FT 100S is sending a loop pattern and waiting for an indication that the remote unit has entered loopback mode.

If the local unit does not receive the indication, it sends the loop-up code indefinitely until commanded otherwise.

A message appears on the LCD when the remote unit responds successfully followed by the IN PROGRESS-END? display.

PUSHBUTTON ACTION:

- YES- None
- NO/
- HOME Sends loopdown pattern and returns to test request display

Diagnostic Options Main Menu 2, Cont.

**DTE (xxx)
In Progress - End?**

The control port is in a test mode where *xxx* is either "Rem w /TP" or "Remote." If Remote Loopback with a Test Pattern is selected, the local unit is also sending and monitoring a 511 test pattern.

PUSHBUTTON ACTION:

- YES- Sends loopdown pattern and returns to test request display
- NO- Advances to BIT ERROR display
- HOME- Returns to DTE PORT TESTS? submenu

**Looping Down
Remote DSU**

The local unit is sending a sequence requesting the remote unit to leave the loopback mode.

The loop-down code is a 5 bit repeating pattern (11100).

PUSHBUTTON ACTION:

- YES/
- NO/
- HOME- Returns to DTE PORT TESTS? submenu

Diagnostic Options Main Menu 2, Cont.

If the unit has been put into a loopback mode by a remote unit, this display appears:

**DTE Remotely
Looped up - End?**

PUSHBUTTON ACTION:

YES- Takes the unit out of loopback mode, but if the remote unit continues to send the loop-up pattern, the unit returns to loopback mode after a few seconds

NO- None

HOME- Returns to DTE PORT TESTS? submenu

**DTE Port Test
Pattern**

**Test Pattern
Test?**

Figure 4-7 shows the DTE port in the Test Pattern Test. DTE transmitted data is replaced by an internally generated 511 test pattern and sent to the remote FT 100S. Also, local receive data is monitored for the same test pattern. An LCD message indicates detected test pattern errors.

The TM LED lights to indicate a test mode in progress. Other LEDs function normally.

PUSHBUTTON ACTION:

YES- Enters test pattern test; advances to TEST PATTERN IN PROGRESS - END?

NO/

HOME- Returns to DTE PORT TESTS? submenu

Diagnostic Options Main Menu 2, Cont.

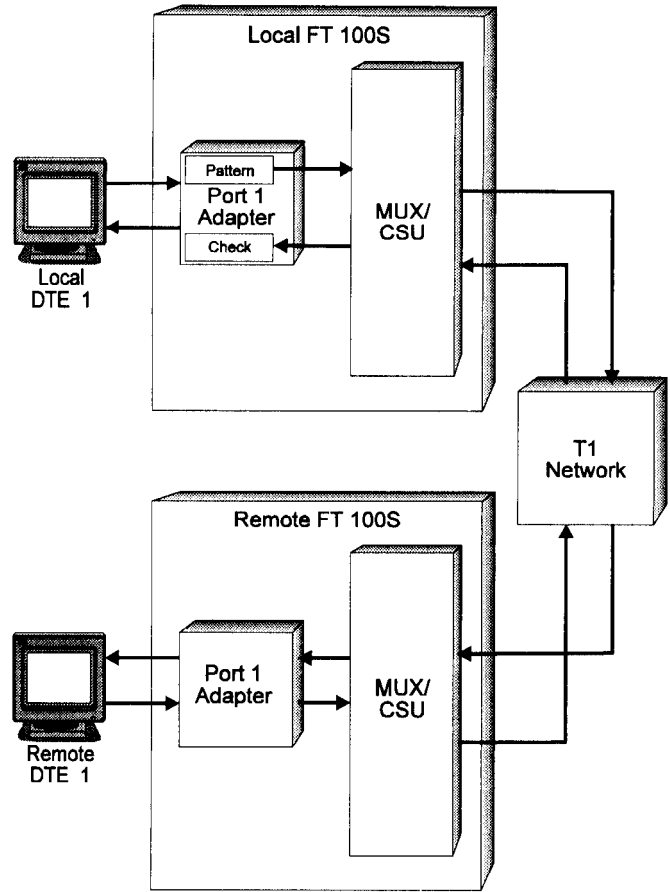

Figure 4-7
DTE Port Test Pattern Test

Diagnostic Options Main Menu 2, Cont.

Test In Progress

XXX
In Progress-End?

This display indicates a test is in progress. XXX represents the particular test mode.

PUSHBUTTON ACTION:

- YES- Terminates the test
- NO- Advances to next test menu
- HOME- Returns to top of the present test menu

Bit Errors Display

DTE Test Pat
Bit Errors: nnnnnn

When a test includes a test pattern (RLTP or TP), this display shows the number of errored bits received since the test was entered or restarted.

PUSHBUTTON ACTION:

- YES- No action
- NO- Advances to average BER display
- HOME- Returns to the top of the present test menu

**Average Bit Error
Rate Display**

DTE Test Pat
Avg. BER: n.nE-nn

This display shows the average number of errored bits received since the test was entered or restarted. The value appears in exponential notation.

$$\text{Avg Ber} = \frac{\# \text{ of bit errors}}{\text{total bits received}}$$

PUSHBUTTON ACTION:

- YES- No action
- NO- Advances to the elapsed seconds display
- HOME- Returns to the top of the present test menu

Diagnostic Options Main Menu 2, Cont.

**Elapsed Seconds
Display**

DTE Test Pat
Elapsed Sec.: nnnnn

This display shows the number of seconds that have elapsed since the test was entered or restarted.

PUSHBUTTON ACTION:

- YES- No action
- NO- Advances to RESTART TEST?
- HOME- Returns to the top of the present test menu

**Restart Test
Display**

DTE Test Pat
Restart Test?

The user can reset the bit error count, average BER, and elapsed seconds for the test pattern tests if desired.

PUSHBUTTON ACTION:

- YES- Restarts the error counters and returns to the BIT ERRORS display
- NO/
- HOME- Returns to the top of the present test menu

SELF TEST

Even though there is no singular self test command or function, there is self test capability in the FT100S.

To execute a self test, first enter the T1 LOCAL LOOPBACK MODE previously described in this chapter. Next, with the T1 Local Loopback still active, enter the DTE TEST PATTERN MODE previously described in this chapter. Using the LCD, it is possible to determine if the unit is operating error free. Figure 4-8 shows the FT100S in self test.

Diagnostic Options Main Menu 2, Cont.

To terminate the FT100S self test, the user must terminate the DTE TEST PATTERN MODE and the T1 LOCAL LOOPBACK MODE as described previously in this chapter.

Local FT100S

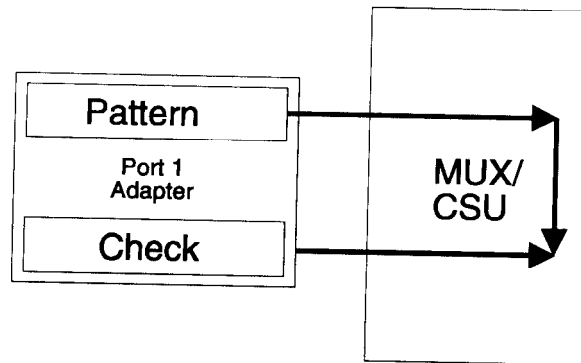

Figure 4-8
FT100S Self Test Function

Diagnostic Options Main Menu 2, Cont.

DS0 MONITOR

**Monitor DS0
Display?**

The user can monitor activity on any selected DS0 data channel on the T1 network receive signal. Data displays on the LCD in an 8-bit field with the least significant bit to the right.

Use the YES/NO pushbuttons to select the DS0 channel number as described following the display diagram below.

PUSHBUTTON ACTION:

- YES- Enters DS0 monitor display
- NO- Advances to the PERFORMANCE HISTORY DISPLAY? submenu
- HOME- Returns to DIAGNOSTIC OPTIONS? menu

**Channel Data
nnnnnnn**

PUSHBUTTON ACTION:

- YES- Decrements the displayed channel number # # # # = 1 to 24
- NO- Increments the displayed channel number # #
- HOME- Returns to the MONITOR DS0 DISPLAY? submenu

Diagnostic Options Main Menu 2, Cont.

**PERFORMANCE
HISTORY**

Performance History Display?

The FT 100S continuously monitors the network received signal for various error conditions. This information is accumulated, it is stored in nonvolatile memory, and it can be accessed and displayed on the LCD as well as via the external control port on the controlling DTE monitor. Refer to Chapter 6 for a description of performance history access by the control port.

The Performance History submenu first accesses these two error events:

- % Error free seconds
- Error count

PUSHBUTTON ACTION:

YES- Advances to ERROR FREE SECS: display

NO/

HOME- Returns to DIAGNOSTIC OPTIONS? menu

Diagnostic Options Main Menu 2, Cont.

**% Error Free
Seconds**

Error Free Secs:
nn%

The percentage of error free seconds for the past 24 hours is displayed.

It is defined as

$$nn = (\# \text{ of error free seconds}) / (\# \text{ of total seconds}) \times 100$$

PUSHBUTTON ACTION:

- YES- None
- NO- Advances to the ERROR COUNT DISPLAY?
- HOME- Returns to PERFORMANCE HISTORY DISPLAY? submenu

Error Events

Error Events:
nnn

This display indicates the total error event count *nnn* since the last time the count was reset.

If ESF framing is selected, an error event is either a CRC error or an Out of Frame Error (OOF).

If SF framing is selected, an error event is either a bipolar violation (BPV) or an OOF error.

PUSHBUTTON ACTION:

- YES- None
- NO- Advances to the CURRENT INTERVAL DISPLAY?
- HOME- Returns to PERFORMANCE HISTORY DISPLAY? submenu

Diagnostic Options Main Menu 2, Cont.

Timed Error Data Performance history is accumulated and stored in intervals of 15 minutes each for a maximum of 24 hours (96 intervals).

24 Hour Totals

15 Min Interval Data?

These menus access displays recording error totals within

- the last 24 hours
- the current 15 minute interval
- or any 15 minute interval during the past 24 hour period.

The following error count displays may be accessed:

Interval ES
nnn

Interval BES
nnn

Interval SES
nnn

Interval UAS
nnn

Interval LOFC
nnn

Interval LCVS
nnn

The first column distinguishes the time option "menu" for that data. (The first column of each of the Current Interval displays includes the current interval second, 1 to 900.)

The second column records the total error count nnn per the specific type of error data:

- | | |
|------|-----------------------------|
| ES | Errored seconds |
| BES | Bursty errored seconds |
| SES | Severely error seconds |
| UAS | Unavailable seconds |
| LOFC | Loss of frame count |
| LCVS | Line code violation seconds |

Diagnostic Options Main Menu 2, Cont.

The

**15 Min Interval
Data?**

time menu prompt also accesses an

Interval # # ?

prompt which allows the user to indicate which 15 minute interval (01-96) in the last 24 hours should be displayed.

PUSHBUTTON ACTION:

- YES-** At each of the "menu" prompts (*current, 24 hours, or any 15 minutes*), YES advances to the first error count display within the "menu." Within a time option menu, YES advances to the same error data type in the next interval. For example, if BES of interval 2 is currently displayed, pushing YES will advance to BES of interval 3.
- NO-** At "menu" prompts, NO scrolls through the time option "menus;" within a time option "menu," NO advances through the six error count displays.
- HOME-** Returns to PERFORMANCE HISTORY DISPLAY? submenu

**CONFIGURATION
OPTIONS
MAIN MENU 3**

**Configuration
Options?**

This menu allows displaying and changing how the unit is configured to operate.

The four submenus are

- T1 line options
- DTE port options
- Control port options
- Set time and date

PUSHBUTTON ACTION:

YES- Advances to T1 LINE OPTIONS? sub-menu

NO/

HOME- Returns to the FT 100S T1 CSU/DSU main menu header

T1 LINE OPTIONS

**T1 Line
Options?**

This submenu allows viewing and changing the FT 100S / T1 line operating characteristics.

Options accessed by this submenu include

- T1 framing
- T1 line code
- ESF PRM transmission
- ESF reporting per 54016
- Timing
- Line loopback
- Payload loopback
- Idle code

Configuration Options Main Menu 3, Cont.

PUSHBUTTON ACTION:

- YES- Advance to T1 framing option display: T1 FRAMING = SF (ESF) CHANGE IT?
- NO- Advances to DTE PORT OPTIONS? submenu
- HOME- Returns to CONFIGURATION OPTIONS? menu

T1 Framing

**T1 Framing = ESF
Change It?**

The T1 network signal framing mode can be set to either Superframe (SF or D4) or Extended Superframe (ESF) mode.

PUSHBUTTON ACTION:

- YES- Toggles between ESF and SF(D4)
- NO- Saves option selected
- HOME- Returns to T1 LINE OPTIONS? submenu

Line Code

**Line Code = AMI
Change It?**

Select one of two options for the network T1 line code:

- AMI Alternate mark inversion
- B8ZS Binary 8-zero substitution: With B8ZS, a bipolar violation sequence replaces strings of 8 zeros in the transmit data and insures a minimum ones density to the network.

PUSHBUTTON ACTION:

- YES- Toggles between AMI and B8ZS
- NO- Saves option selected and advances to PRM option
- HOME- Returns to T1 LINE OPTIONS? submenu

Configuration Options Main Menu 3, Cont.

Bit Stuffing

Bit Stuff = EN
Change It?

Bit stuffing for the network T1 line can be DISABLED or ENABLED when using the AMI line code option. This option does not apply to the B8ZS line code option.

PUSHBUTTON ACTION:

- YES- Toggles between DISABLE and ENABLE
- NO- Saves option selected and advances to PRM option
- HOME- Returns to T1 LINE OPTIONS? submenu

ANSI Error History

ESF (PRM) = OFF
Change It?

ESF FRAMING OPTION ONLY

Enable or disable transmission of the performance report message (PRM) defined by ANSI T1.403. When enabled, the PRM is transmitted toward the network once per second on the facility data link (FDL). The PRM contains error performance data accumulated during the previous 4 seconds.

PUSHBUTTON ACTION:

- YES- Toggles between on and off
- NO- Saves option selected and advances to ESF AT&T mode option
- HOME- Returns to T1 LINE OPTIONS? submenu

Configuration Options Main Menu 3, Cont.

**AT&T Error
History**

**ESF (AT&T) = OFF
Change It?**

ESF FRAMING OPTION ONLY

Enable or disable ESF error reporting as defined by AT&T publication 54016. ESF error reporting allows central office equipment to request the error performance history from the unit via the FDL. When the request is received, the unit transmits the 24-hour performance history to the central office also via the FDL.

PUSHBUTTON ACTION:

YES- Toggles between on and off

NO- Saves option selected and advances to **TIMING** option

HOME- Returns to **T1 LINE OPTIONS?** submenu

Timing

**Timing = LOOP
Change It?**

This option selects the timing mode. Selections are

- Loop** The unit synchronizes all timing and clocks to the network T1 receive signal. In this mode, the unit supplies transmit and receive clocks to the DTE port. This is the most common selection when the unit is connected to a telephone company T1 service.
- Internal** The unit synchronizes all timing and clocks to an internally generated timing source. In this mode, the unit supplies transmit and receive clocks to the DTE port.
- DTE** The unit synchronizes all timing and clocks to the selected DTE's external transmit clock.

Configuration Options Main Menu 3, Cont.

Either internal or DTE port timing can be useful in applications where the unit is directly connected to another FT 100S or T1 multiplexer, such as in local area networks and central office bypass connections. In these applications, only one unit should be selected for internal or DTE port timing while the other is selected for loop timing.

PUSHBUTTON ACTION:

- YES- Scrolls timing options
- NO- Saves option selected and advances to LINE LB option
- HOME- Returns to T1 LINE OPTIONS? submenu

Line Loopback

Line LB = DIS Change It?

If Line Loopback is enabled, the unit enters into a network loopback when a Line Loopback code is detected on the network. This signal allows easier fault diagnosis by the T1 service provider. When this option is disabled, the unit ignores an incoming Line Loopback code.

PUSHBUTTON ACTION:

- YES- Toggles between enabled and disabled
- NO- Saves selected option and advances to PAYLOAD LB option
- HOME- Returns to T1 LINE OPTIONS? submenu

Configuration Options Main Menu 3, Cont.

Payload Loopback

Payload LB = DIS
Change It?

This option is similar to Line Loopback except that the contents of the DS0s are reframed before being transmitted back out on the network.

PUSHBUTTON ACTION:

- YES- Toggles between enabled and disabled
- NO- Saves selected options and advances to IDLE CODE option
- HOME- Returns to T1 LINE OPTIONS? submenu

Idle Code

Idle Code = FF
Change It?

Select the FF pattern for all ones or the 7F pattern to be inserted into unused DS0s.

PUSHBUTTON ACTION:

- YES- Toggles between idle code FF and 7F
- NO- Saves selected option and advances to Yellow Alarm
- HOME- Returns to T1 LINE OPTIONS? submenu

Yellow Alarm

Yellow Alm = DIS
Change It?

This option setting determines whether or not Yellow Alarms will be sent out on the network.

PUSHBUTTON ACTION:

- YES- Toggles between enabled and disabled
- NO/
- HOME - Returns to T1 LINE OPTIONS? submenu

Configuration Options Main Menu 3, Cont.

**DTE PORT
OPTIONS**

**V.35 or RS-530
Interface Card**

**DTE Port
Options?**

This submenu allows viewing and changing the DTE port operating characteristics. Options accessed by this submenu include

- Port data rate
- DS0 time slot assignment
- Transmit clock source
- Transmit clock polarity
- Receive clock polarity
- Interface control signal options

PUSHBUTTON ACTION:

- YES-** Advances to the port data rate display
- NO-** Advances to CONTROL PORT OPTIONS? submenu
- HOME-** Returns to CONFIGURATION OPTIONS? menu

Note: The following options are displayed in blinking fields on the LCD. The option displayed is the present option selected. Pressing NO scrolls through the selections. When the desired selection is displayed, press YES.

Configuration Options Main Menu 3, Cont.

Port Data Rate

DTE Port <type> <i>nn</i> x <i>rr</i> = <rate>

Select the data rate from 56 kbps to 1.536 Mbps with the following simple multiplication:

$$\begin{array}{r} \textit{nn} \quad (\text{number of DS0 time slots}) \\ x \textit{rr} \quad (\text{rate multiple: 56 or 64 kbps}) \\ \hline \textit{rr} \quad = \textit{data rate} \end{array}$$

The *nn* blinks to prompt the user to confirm the current number of DS0 time slots or to increment the number.

PUSHBUTTON ACTION:

- YES- Selects the number of DS0 time slots *nn* and blinks the rate multiple *rr*
- NO- Increments the number of DS0 time slots *nn*
- HOME- Returns to Port Number Selection

Configuration Options Main Menu 3, Cont.

The display remains but the pushbutton action will now act differently so that the rate multiple can be changed:

DTE Port <type>
nn x rr = <rate>

PUSHBUTTON ACTION:

- YES- Selects the rate multiple *rr* and advances to DS0 time slot assignment display
- NO- Toggles rate multiple between 56 and 64 kbps
- HOME- Returns to Port Number Selection

DS0 Time Slot Assignment

DTE Port <type>
xxxx CH: ff to ll

This display allows assigning DS0 time slots to the selected port.

- xxxx = alternating or contiguous DS0 channels
- ff = first DS0 channel number
- ll = last DS0 channel used by the selected port
-- automatically determined by *ff* and port data rate display *nn* selection

xxxx blinks to prompt the user to confirm the current selection or toggle to the other one.

PUSHBUTTON ACTION:

- YES- Selects alternating or contiguous DS0 assignment *xxxx* and blinks the starting DS0 number *ff*
- NO- Toggles between ALT and CONT DS0 assignment modes
- HOME- Returns to Port Number Selection

Configuration Options Main Menu 3, Cont.

DTE Port <type>
xxx CH: ff to ll

PUSHBUTTON ACTION:

- YES- Selects the first DS0 channel number *ff* and advances to the transmit clock source display
- NO- Increments the starting DS0 number *ff* and displays the ending DS0 number *ll*
- HOME- Returns to Port Number Selection

Transmit Clock Source

DTE Port <type>
Tx CLK = <source>

This display selects the DTE transmit clock source:

- Internal The unit uses the transmit clock output to clock DTE transmit data into the transmit buffer. Where the DTE is located near the unit, internal clock is usually selected.
- External The unit uses the external transmit clock from the DTE to clock DTE data. In applications with a high bit rate and a long DTE cable, it may be necessary to use the external clock option.

In external clock operation, the transmit clock output from the unit is routed to the DTE and sent back to the unit along with the data line. This eliminates any phase misalignment between the clock and data signal due to cable phase delay and insures a proper signal / clock relationship at the unit input.

PUSHBUTTON ACTION:

- YES- Selects the displayed option and advances to transmit clock polarity display
- NO- Toggles between INTERNAL and EXTERNAL options
- HOME- Returns to Port Number Selection

Configuration Options Main Menu 3, Cont.

**Transmit Clock
Polarity**

DTE Port <type>
Tx CLK = <polarity>

PUSHBUTTON ACTION:

- YES- Selects the displayed clock polarity option and advances to receive clock polarity display
- NO- Toggles between NORMAL and INVERT options
- HOME- Returns to Port Number Selection

**Receive Clock
Polarity**

DTE Port <type>
Rx CLK = <polarity>

PUSHBUTTON ACTION:

- YES- Selects the displayed clock polarity option and advances to the CTS signal operation display
- NO- Toggles between NORMAL and INVERT options
- HOME- Returns to Port Number Selection

**CTS Signal
Operation**

DTE Port <type>
CTS = <mode>

The CTS output may be selected for normal operation or forced on. When normal is selected, CTS is asserted approximately 10 ms after RTS is received.

PUSHBUTTON ACTION:

- YES- Selects the displayed CTS operation mode and advances to the RLSD signal operation display
- NO- Toggles between NORMAL and FORCED ON
- HOME- Returns to Port Number Selection

Configuration Options Main Menu 3, Cont.

**RLSD Signal
Operation**

DTE Port <type>
RLSD = <mode>

Select normal or forced on operation for RLSD output. Selecting normal turns RLSD on when the FT 100S T1 receiver has acquired frame synchronization and off when frame synchronization is lost or no signal is present.

PUSHBUTTON ACTION:

- YES- Selects the displayed RLSD operation mode and advances to DSR signal operation display
- NO- Toggles between NORMAL and FORCED ON
- HOME- Returns to Port Number Selection

**DSR Signal
Operation**

DTE Port <type>
DSR = <mode>

Select normal or forced on operation for DSR output. Selecting normal turns DSR on when the FT 100S T1 receiver has acquired frame synchronization and off when frame synchronization is lost or no signal is present.

PUSHBUTTON ACTION:

- YES- Selects the displayed DSR operation mode and advances to TM signal operation
- NO- Toggles between NORMAL and FORCED ON
- HOME- Returns to Port Number Selection

Configuration Options Main Menu 3, Cont.

**TM Signal
Operation**

DTE Port <type>
TM = <mode>

The TM signal indicates to the DTE that the unit is in a test mode. Select normal or forced off operation for TM output. Selecting normal turns TM on if the unit is in a test mode.

PUSHBUTTON ACTION:

- YES- Selects the displayed TM operation and advances LL signal operation
- NO- Toggles between NORMAL and FORCED OFF
- HOME- Returns to Port Number Selection

**LL Signal
Operation**

DTE Port <type>
LL = <mode>

This option determines whether the unit acknowledges or ignores an LL signal from the DTE.

If enabled, the LL signal causes the DTE port to enter Local Terminal Loopback. Otherwise, the LL signal is ignored.

PUSHBUTTON ACTION:

- YES- Selects the displayed LL operation mode and RL signal operation
- NO- Toggles between ENABLE and DISABLE
- HOME- Returns to Port Number Selection

Configuration Options Main Menu 3, Cont.

**RL Signal
Operation**

DTE Port <type> RL = <mode>

This option determines whether the unit acknowledges or ignores an RL signal from the DTE.

If enabled, the RL signal causes the DTE port to enter Remote Terminal Loopback. Otherwise, the RL signal is ignored.

PUSHBUTTON ACTION:

- YES- Selects displayed RL operation mode
- NO- Toggles between ENABLE and DISABLE
- HOME- Returns to Port Number Selection

**Remote Loopback
Operation**

DTE Port <type> RA/RTL = <mode>

This option determines whether the unit acknowledges or ignores a loop-up pattern from the remote CSU/DSU.

Enable The unit goes into Remote Terminal Loopback when the loop sequence is detected.

Disable The unit ignores the sequence.

PUSHBUTTON ACTION:

- YES- Selects displayed RA/RTL mode
- NO- Toggles between ENABLE and DISABLE
- HOME- Returns to Port Number Selection

Configuration Options Main Menu 3, Cont.

**CONTROL PORT
OPTIONS**

**Control Port
Options?**

This submenu allows selecting the control port operating characteristics. The unit can be externally controlled by a terminal or computer connected to the rear panel RS-232 CONTROL port or by the LocalView terminal when installed in the UDS LocalView shelf. Chapter 6 describes control port operation.

The options are

- Control mode
- Baud rate
- Local echo
- Status

PUSHBUTTON ACTION:

- YES- Advances to control mode
NO- Advances to SET TIME submenu
HOME- Returns to CONFIGURATION OPTIONS? menu

Configuration Options Main Menu 3, Cont.

Control Mode

Mode = <mode> Change It?

The control port mode options are

Terminal allows operation with a standard ASCII terminal or computer connected to the control port. Responses from the unit are formatted ASCII text screens.

Computer allows operation with a computer or modem connected to the control port. Responses from the unit are short unformatted ASCII messages.

LocalView allows operation with the LocalView Management System when installed in a LocalView shelf. In this mode, the rear panel control port is not used.

PUSHBUTTON ACTION:

YES- Scrolls the options

NO- Selects the displayed mode and advances to the baud rate option

HOME- Returns to CONTROL PORT OPTIONS? submenu

Configuration Options Main Menu 3, Cont.

Baud Rate

Bit Rate = <rate>
Change It?

The baud rate options are

- 300
- 600
- 1200
- 2400
- 4800
- 9600
- 19200

PUSHBUTTON ACTION:

- YES- Scrolls through the baud rate options
NO- Advances to LOCAL ECHO
HOME- Returns to CONTROL PORT OPTIONS?
 submenu

Local Echo

Local Echo = ON
Change It?

This option determines whether or not the unit echoes characters back to the control port terminal.

PUSHBUTTON ACTION:

- YES- Toggles between on and off
NO- Advances to control port status.
HOME- Returns to CONFIGURATION OPTIONS?
 menu

Configuration Options Main Menu 3, Cont.

**SETTING A
PASSWORD**

**Status = Unlock
Change It?**

This submenu gives the user the option of requiring a password for remote access to the unit via the control port.

When the status is "Lock" the control port will prompt the user to enter the password. Refer to Chapter 6 for details on password operation and settings.

When unlocked no password prompt is displayed on the control terminal.

PUSHBUTTON ACTION:

YES- Toggles between lock and unlock.

NO/

HOME- Returns to CONFIGURATION OPTIONS?
menu

Configuration Options Main Menu 3, Cont.

SET TIME AND DATE

These options allow setting the realtime clock to the current time and date. The unit uses the realtime clock for performance history time and date stamping. When the performance history is accessed through the control port, the time and date are displayed along with the error history.

hh : mm : ss
Set Time?

PUSHBUTTON ACTION:

- YES- Advances to hour display; accepts current setting for hour, minute, second displays
- NO- Advances to SET DATE? option; in hour, minute, second displays, increments digits for setting
- HOME- Returns to CONFIGURATION OPTIONS? menu

Month dd, year
Set Date?

PUSHBUTTON ACTION:

- YES- Advances to month display; accepts current setting for month, day, and year displays
- NO- Returns to CONFIGURATION OPTIONS? menu; in month, day, and year displays, increments digits for setting
- HOME- Returns to CONFIGURATION OPTIONS? menu

Chapter 5 Operation

GENERAL	After installation and configuration, the FT 100S operates automatically and unattended.
CONTROLS AND INDICATOR	The FT 100S front panel contains three pushbuttons (YES, NO, HOME), a 2 line by 16 character liquid crystal display (LCD), and six light emitting diode (LED) indicators. Almost all configuration options and diagnostic features can be accessed by using the LCD and pushbuttons. Chapter 4 describes front panel option selection.
LED DESCRIPTION	The six front panel LEDs on the FT 100S consist of the following:
TD	Transmit data indicates activity on the DTE transmit data line. Flashing indicates data is being transmitted. Solid ON indicates a low state on the transmit data line, and a solid OFF indicates a high state or no data being transmitted.
RD	Receive data indicates activity on the DTE receive data line. Flashing indicates data is being received. Solid ON indicates a low state on the receive data line, and a solid OFF indicates a high state or no data being received.
CS	Clear to send indicates the status of the DTE clear to send signal.
LOS	Loss of sync indicates that the unit has either lost the network T1 frame sync or the signal.

ALM	Alarm indicates an alarm condition exists on the T1 network interface.
TM	Test mode indicates that the unit is in a network or DTE test mode.

Chapter 6 Control Port Operation

GENERAL

The rear panel port labeled CONTROL provides the connection for configuration and status display via terminal monitor.

The control port is an EIA-232 compatible serial interface. Table 2-2 lists pin connections for this interface. The interface is the same as the serial I/O connector on AT style personal computers so that standard cables can be used.

Using Control Port Commands

Control port commands are entered from the control keyboard and consist of short character strings followed by a carriage return which select and display the various menus and options.

Figure 6-1 provides a menu flow chart indicating the access path via command through the available menus.

Any command or option choice can be entered from any screen. This feature allows easier configuration changes when the user is familiar with the command strings.

Refer to Chapter 4, Front Panel Option Selection, for further information on options.

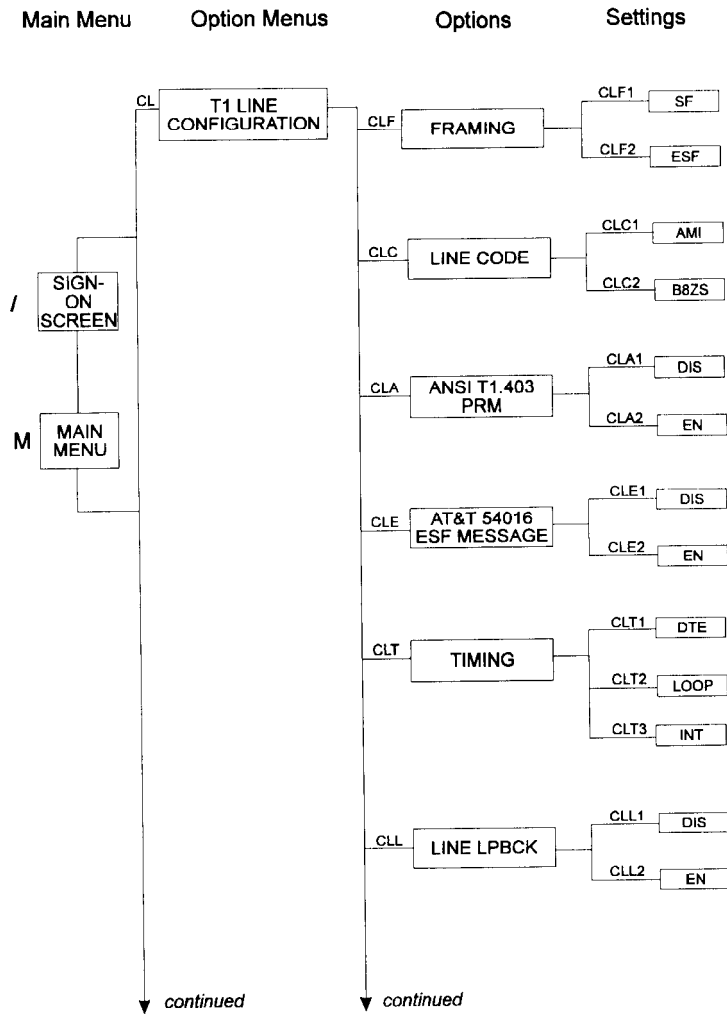

Figure 6-1
Menu Flow Chart

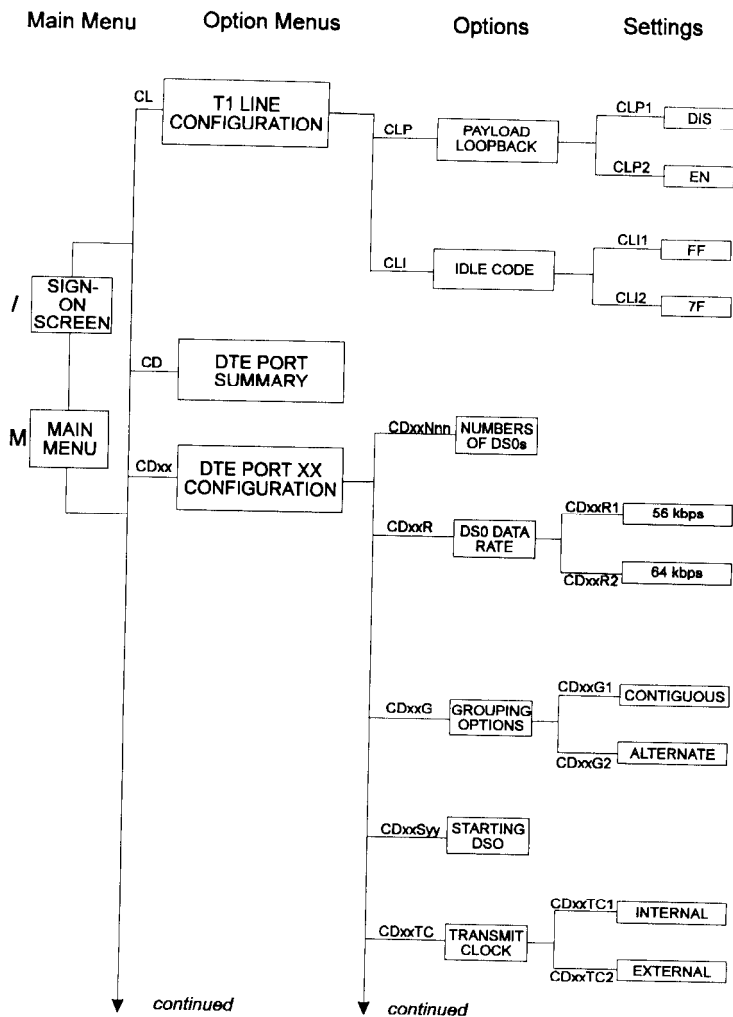

Figure 6-1, cont.
Menu Flow Chart

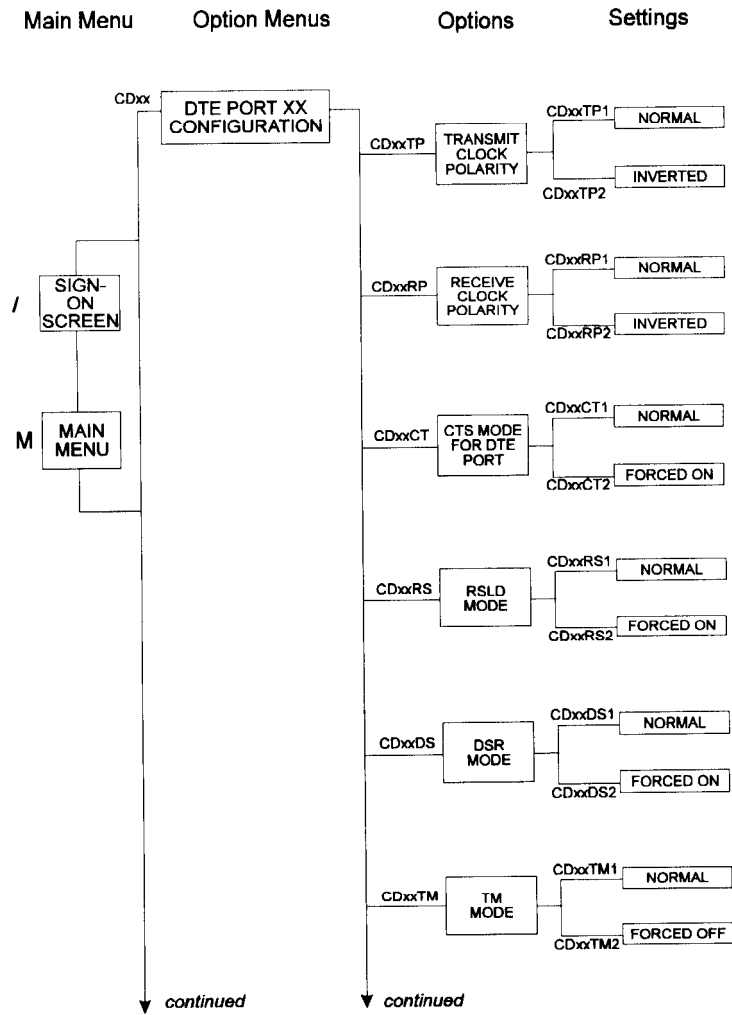

Figure 6-1, cont.
Menu Flow Chart

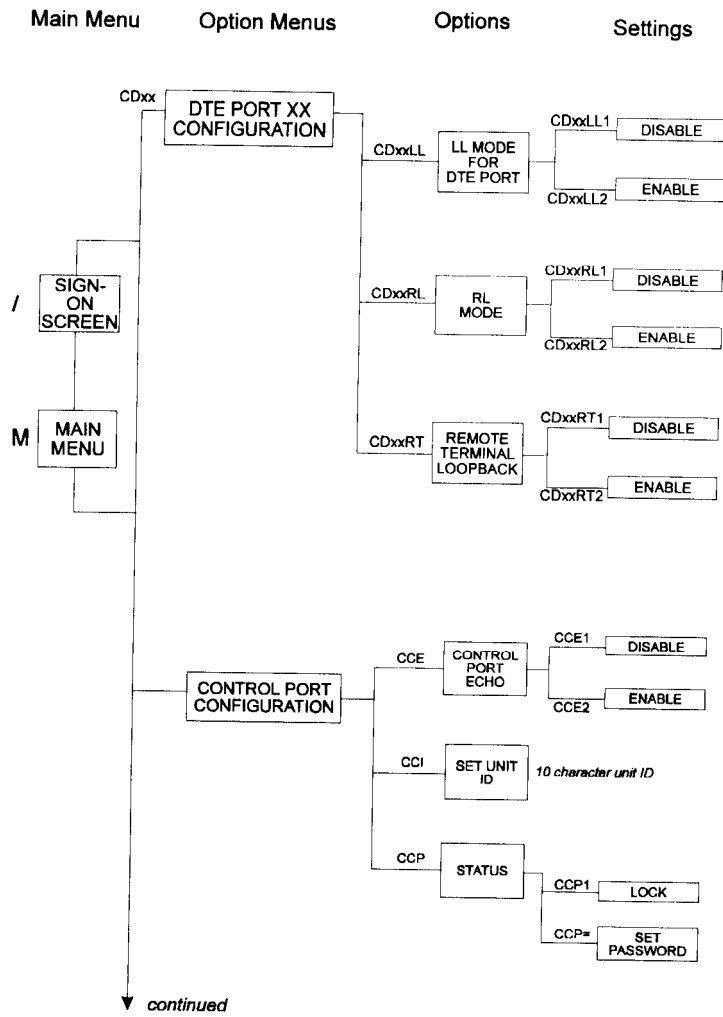

Figure 6-1, cont.
Menu Flow Chart

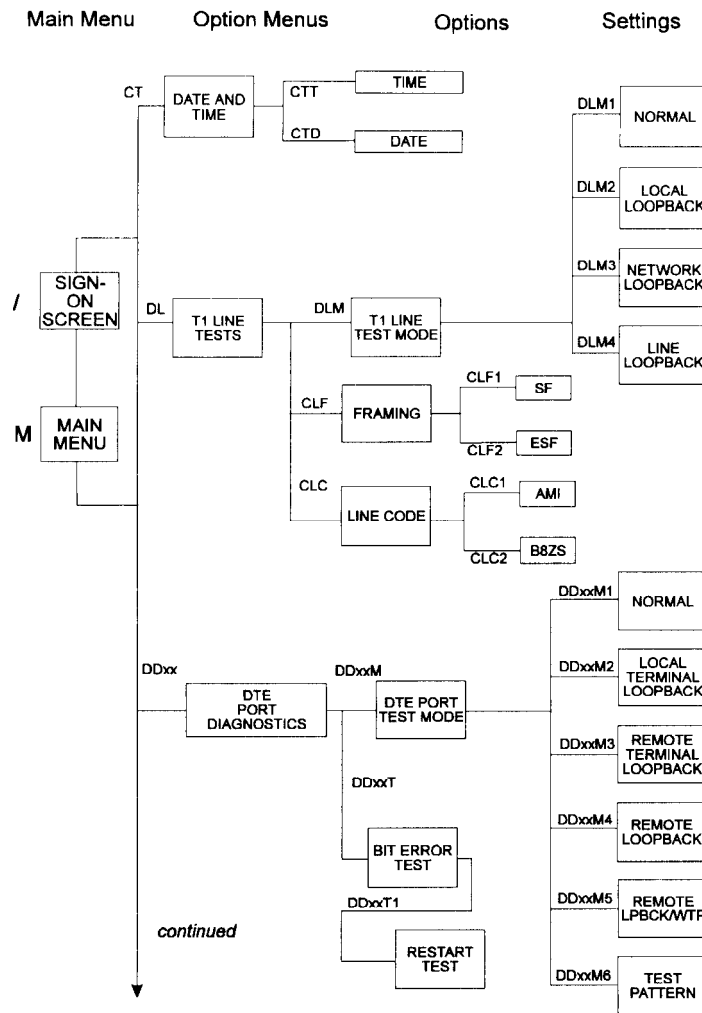

Figure 6-1, cont.
Menu Flow Chart

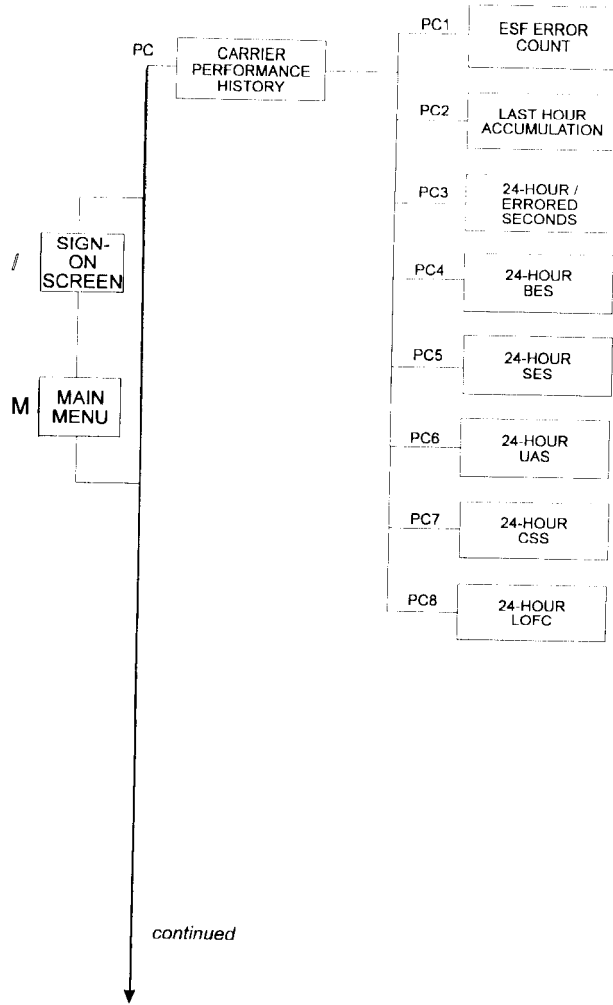
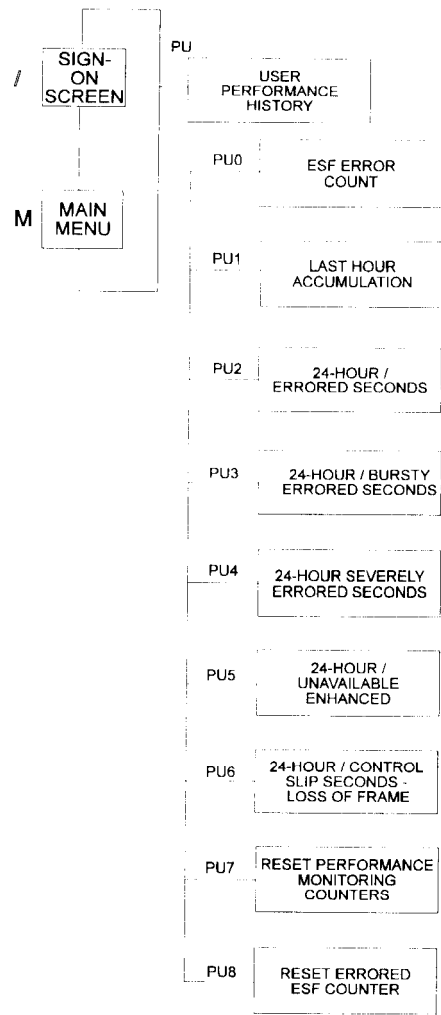

Figure 6-1, cont.
Menu Flow Chart



*Figure 6-1, cont.
Menu Flow Chart*

CONNECTING TO A TERMINAL

To operate the unit with a CRT terminal:

Connect the FT 100S control port to a terminal with a standard PC 25 pin to 9 pin conversion cable. Refer to Table 2-2 for pin connections.

Using the front panel, select terminal operation and the desired control port baud rate, and enable local character echo if desired.

Word length is fixed at 8 data bits with 1 stop bit and no parity.

Enter a / on the keyboard to display the sign-on screen:

```
=====
                        UDS/MOTOROLA
=====
FFFFFFFF  TTTTTTTT   11      0000   0000   SSSS
FFFFFFFF  TTTTTTTT   111     000000 000000 SSSSSS
FF       TT         1111    000 000 000 000 SSS SS
FF       TT         11      00  00  00  00  SS
FF       TT         11      00  00  00  00  SSS
FFFFFFFF  TT         11      00  00  00  00  SSSS
FFFFFFFF  TT         11      00  00  00  00  SSSS
FF       TT         11      00  00  00  00  SSS
FF       TT         11      00  00  00  00  SSS
FF       TT         11      000 000 000 000 SS  SSS
FF       TT         11111111 000000 000000 SSSSSS
FF       TT         11111111 0000   0000   SSSS
=====
COPYRIGHT 1992 by UDS/MOTOROLA                      VERSION: n.n
=====
ENTER 'M' TO GO TO MAIN MENU
```

**CONNECTING TO
A MODEM**

The FT 100S can be controlled remotely by a telephone line modem connected to the control port.

While not required, it is recommended that a modem with an error control protocol like MNP be used for remote control to prevent control command errors from accidentally reconfiguring the unit.

Connect a null modem device or crossover cable between the FT 100S control port and modem. Refer to Table 2-2 for control port pin connections.

Using the front panel, select terminal operation, the desired control port baud rate, and local echo if desired.

Word length is fixed at 8 data bits with 1 stop bit and no parity.

Enter a / on the keyboard to display the sign-on screen.

**CONNECTING TO
LOCALVIEW**

An FT 100S can be used in the LocalView System. To do this, select LocalView mode from the FT 100S front panel.

The FT 100S now operates under the control of the LocalView controller card using the device driven mode as described in the LocalView System User's Manual.

In LocalView, select the FT 100S. Operation and option selection for the FT 100S are the same as in direct communications between the unit and a terminal.

To end communications between the unit and LocalView, enter an ESC on the keyboard. The LocalView controller card returns to the LocalView Network Map.

MAIN MENU

The Main Menu accesses all other menus, configuration commands, and option settings. After the illustrations of the first three menus, this manual discusses the menus without further illustrations.

Enter any command from any screen for faster configuration changes. The user does not have to choose options only from the menu or option selections currently displayed. Appendix B lists all menus and options.

Enter M to display the Main Menu:

```
=====
                        UDS/MOTOROLA
                        FT 100S
                        MAIN MENU
=====
T1 LINE CONFIGURATION:  CL
DTE PORT SUMMARY:      CD
DTE PORT xx CONFIGURATION: CDxx
CONTROL PORT CONFIGURATION: CC
SET TIME & DATE:       CT
REMOTE CONFIGURATION COMMANDS: CR

T1 LINE DIAGNOSTICS:   DL
DTE PORT xx DIAGNOSTICS: DDxx

CARRIER PERFORMANCE HISTORY: PC
USER PERFORMANCE HISTORY:  PU
=====
ENTER SELECTION:
```

Entering Displays

CL T1 Line Configuration Options:

- Framing
- Line code
- ANSI.403 PRM
- AT&T 54016 ESF message
- Timing
- Line loopback
- Payload loopback
- Idle code

Entering	Displays
CD	DTE Port Summary
CDxx	Port xx Configuration Options: <ul style="list-style-type: none">• Numbers of DS0s• Data rate• Grouping options• Starting DS0• Transmit clock• Transmit clock polarity• Receive clock polarity• CTS mode• RSLD• DSR• TM• Local loopback• Remote loopback• Remote terminal loopback
CC	Control Port Configuration Options: <ul style="list-style-type: none">• Echo• Status
CT	Time and Date Options
DL	T1 Line Test Options: <ul style="list-style-type: none">• Normal, local loopback• Network loopback• Line loopback• Framing• Line code

	DDxx	the DTE Port Test Options: <ul style="list-style-type: none">• Local terminal loopback• Remote terminal loopback• Remote loopback with test pattern• Test pattern
	PC	Carrier Performance Options
	PU	User Performance Options
T1 LINE CONFIGURATION	Enter CL	to display the T1 Line Configuration Option Menu
	Entering	Displays
	CLF	T1 Framing Select SF or ESF.
	CLC	T1 Line Code Select AMI or B8ZS.
	CLA	ANSI T1.403 PRM (Performance Report Message) Select disable or enable.
	CLE	AT&T ESF 54016 Message Select disable or enable.
	CLT	T1 Timing Select DTE, loop or internal.
	CLL	Line Loopback Select enable or disable.
	CLP	Payload Loopback Select enable or disable.
	CLI	Idle code Select FF or 7F.

Example: To select the T1 Framing option,

Entering CLF at the ENTER SELECTION prompt displays the two choices for T1 framing:

Superframe (SF) or
Extended superframe (ESF)

Entering CLF2 chooses ESF framing.

The display below shows the screen after this sequence of commands.

```
=====
                        UDS/MOTOROLA
                          FT 100S
                            LOCAL
                        T1 LINE CONFIGURATION MENU
=====

                FRAMING =   CLF   ESF
                LINE CODE =  CLC   AMI
                ANSI T1.403 PRM = CLA  DISABLE
                AT&T 54016 ESF MESSAGE = CLE  DISABLE
                T1 TIMING =   CLT   LOOP
                LINE LOOPBACK =  CLL  DISABLE
                PAYLOAD LOOPBACK = CLP  DISABLE
                IDLE CODE =   CLI   FF
                YELLOW ALARM =  CLY  DISABLE

=====
ENTER SELECTION:
```

Any command can be used to display a menu or set another option can be selected at this point.

DTE PORT SUMMARY

Enter CD to view a summary of the DTE port configurations:

```

=====
                        UDS/MOTOROLA
                        FT 100S
                        LOCAL
DTE PORT CONFIGURATION SUMMARY
=====
                        DSO ASSIGNMENT
PORT 0 0 0 0 0 0 0 0 0 1 1 1 1 1 1 1 1 1 2 2 2 2 2 2
     1 2 3 4 5 6 7 8 9 0 1 2 3 4 5 6 7 8 9 0 1 2 3 4
=====
     01 X X X X X X X X X X X X X X X X X X X X X X X X
=====
                                56   336   V.35
=====
TYPE 'CD01' TO EDIT PORT 01 CONFIGURATION
    
```

The twenty-four columns indicate which DS0s are selected for each port.

The rates for individual DS0s and whole ports are displayed along with the port type, which is determined from the interface card that is installed in the unit.

DTE PORT CONFIGURATION (V.35, RS-530, RS-232 Card)	Enter CDxx	to display DTE Configuration Options.
	Entering	Displays
	CDxxNnn	Number of DS0s Select 00 through 24.
	CDxxR	DS0 Rate Select 56 or 64 kbps.
	CDxxG	DS0 Grouping Select alternate or contiguous.
	CDxxSyy	Starting DS0 Select 01 through 24.
	CDxxTC	Transmit Clock Select internal or external.
	CDxxTP	Transmit Clock Polarity Select normal or inverted.
	CDxxRP	Receive Clock Polarity Select normal or inverted.
	CDxxCT	CTS Mode Select normal or forced on.
	CDxxRS	RLSD Select normal or forced on.
	CDxxDS	DSR Mode Select normal or forced on.
	CDxxTM	TM (test) Mode Select normal or forced on.
	CDxxLL	Local Loopback Select disable or enable.

	Entering	Displays
	CDxxRL	Remote Loopback Select disable or enable.
	CDxxRT	Remote Terminal Loopback Select disable or enable.
CONTROL PORT CONFIGURATION	Entering	Displays
	CC	the Control Port Configuration Menu, which allows the user to select the desired external control port operating mode. The mode and bit rate are only displayed here. The echo option is selectable.
	CCE	Echo Options. Select disable if double characters appear on terminal or enable if no characters appear.
	CCI	Unit Identification Code Select up to 10 characters.
	CCP	Password: When the control port status is locked, the unit asks for the correct password upon initiating terminal control mode or locking the terminal. This prevents unauthorized users from altering option settings (applicable if a modem is used with the control port of the FT 100S). Entering the correct password unlocks the control port. If the control port status is unlocked, no password prompt appears.

Set or change the password using the CCP=command in control mode. The control port may be locked or unlocked at any time from the LCD front panel.

TIME AND DATE	Entering	Displays
	CT	the Update Time And Date Menu, which allows setting the time and date. The unit contains an onboard battery driven realtime clock used as the reference for error history reporting.
	CTThh:mm:s	to update the time, where hh is the hour, mm is the minute, and ss is the second.
	CTDdd/mm/yy	to update the date, where dd is the day, mm is the month, and yy is the year.
T1 LINE TEST OPTIONS	Entering	Displays
	DLM	the T1 Line Tests Menu, which allows initiating tests and monitoring the network portion of the unit. (Refer to Chapter 4, Diagnostic Main Menu 2 section if needed.)
	DLM1	to initiate a T1 Local Loopback.
	DLM2	to initiate a T1 Network Loopback.
	DLM3	to terminate T1 Loopbacks.
	DLM4	to initiate a Line Loopback.

DTE PORT TESTS	Entering	Displays
	DDxxM	the DTE Port Test Menu. (Refer to Chapter 4, Diagnostic Main Menu 2 section if needed.)
	DDxxM1	to return to normal operation
	DDxxM2	to activate a Local Terminal Loopback.
	DDxxM3	to activate a Remote Terminal Loopback.
	DDxxM4	to activate a Remote Loopback.
	DDxxM5	to activate a Remote Loopback with Test Pattern.
	DDxxM6	to activate a Test Pattern.

PERFORMANCE HISTORY

The FT 100S continuously monitors the network received signal for error conditions and alarms.

Performance history information is stored in non-volatile memory and can be accessed and displayed by the local user or transmitted to a remote FT 100S or other T1 terminating facility used for network management.

Entering PC carrier performance history

or

PU user performance history

displays the carrier or user performance history menu.

These two main menus for performance history are described after the sections that list and describe the various error conditions.

Error Condition Categories The unit monitors these error events:

- ESF error count
- SF error count
- Errored seconds
- Bursty errored seconds
- Severely errored seconds
- Unavailable seconds
- Loss of frame count
- Controlled slip second
- Line code violation seconds
- % error free seconds

Error Events

ESF Error Count (ESF framing only)
contains a count of ESF error events. An ESF error event is either a CRC error or an Out of Frame Error (OOF).

SF Error Count (SF framing only)
contains a count of SF error events. An SF error event is either a bipolar violation (BPV) or an out of frame error.

Error Second (ES)
is any second in which an ESF (or SF) error event occurred.

Bursty Errored Second (BES)

in ESF framing is an errored second with more than one but less than 320 ESF error events with no OOF detected.

in SF framing is an errored second with more than one but less than 320 SF error events with no OOF detected.

Severely Errored Second (SES)

in ESF framing is an errored second either with an OOF detected or with 320 or more ESF errored events.

in SF framing is an errored second either with an OOF detected or with 320 or more SF errored events.

Unavailable Second (UAS)

is a count of seconds in which service is unavailable. An unavailable state is declared at the onset of 10 consecutive SES and is cleared at the onset of 10 consecutive seconds with no SES. Also, an unavailable state is declared during power off times of less than 24 hours. If the CSU power is off for more than 24 hours, all error history is reset.

Controlled Slip Second (CSS)

any second with a replication or deletion of a DS1 frame. This data is not detected by the FT 100S, but can be retrieved from the AT&T 54016 compatible equipment.

Loss of Frame Count (LOFC)

is the number of times a loss of frame is declared. Loss of frame is declared after 2.5 seconds of continuous loss of signal or OOF. Loss of frame is cleared after 2.5 seconds of no loss of signal or OOF.

Line Code Violation Second (LCVS)

is any second with one or more bipolar violations. If B8ZS coding is selected, only bipolar violations which are not part of the B8ZS code are counted.

% Error Free Seconds

is defined as { (# of error free seconds) / (# of total seconds) X 100 }. The # of total seconds is counted from the last error history reset to a maximum of 24 hours.

**Error Reporting
Menus**

The performance menus allow the user to select error history display options. Error data for the preceding 24 hours is accumulated in 15 minute intervals and stored in error history registers (nonvolatile memory). Two sets of error history registers are maintained by the unit.

**ESF Per AT&T
Pub 54016**

When selected for AT&T 54016 ESF mode, the two error history registers maintained by the unit are the following:

Carrier Error History Registers
are reserved for use by the carrier or remote T1 interface. The Carrier (or far end T1 terminating equipment) can read these registers over the ESF Data Link (FDL) using the TABS protocol defined by AT&T 54016. The local user can obtain a display of the carrier's error history registers but cannot reset them.

User Error History Registers
are for use by the local user. These registers can be displayed and reset if preferred by the local user.

**ESF Per ANSI
T1.403**

When selected for ANSI T1.403 ESF mode, the two error history registers are the following:

Local Error History Registers
contains error data pertaining to the locally received signal from the network.

Carrier Error History Register
contains error data pertaining to the remotely received signal. This error data is the accumulation of received Performance Report Messages (PRMs) received by the CSU from the network and is a measure of the error performance of the T1 line as observed by the T1 network receive equipment. The PRM protocol is described in ANSI Standard T1.403.

SF Error	When SF framing is selected, the two error history reporting registers are the same as in AT&T 54016. The only difference is that the carrier cannot read the carrier registers since there is no FDL.
Local Error History ANSI T1.403	<p>The local performance history allows display of error history data accumulated by the local FT 100S when ANSI T1.403 ESF mode is selected.</p> <p>The Local 1-Hour Performance Data screen displays a summary of error history accumulated during the previous hour. Also displayed are the 24-hour totals for each error count.</p> <p>The Local 24-Hour Performance Data screen displays all accumulated 15-minute intervals during the previous 24 hours.</p>
Remote Error History Per AT&T 54016	<p>When in the AT&T 54016 ESF mode, remote error history is available over the ESF data link as defined by AT&T Technical Reference 54016. The desired remote error history information may be requested by entering the appropriate selection preceded by an 'R' (see below). If the request is successful, the proper report is displayed. If the request is unsuccessful, the status line indicates an ESF data link communications error.</p> <p>The Remote ESF Performance Data report shows ESF errors counted at the remote FT 100S and the status of the Payload Loopback.</p> <p>The Remote 1-Hour Performance Data report displays the ES, UAS, BES, SES, CSS and LOFC performance data gathered at the remote FT 100S for the last hour period (the data is stored in 15- minute intervals).</p>

The Remote 24-Hour Performance Data reports display their respective error event performance data gathered at the remote FT 100S for the last 24-hour period (the data is stored in 15-minute intervals).

**Carrier
Performance
History**

The Carrier Performance History Menu allows viewing error performance data accumulated by the FT 100S when in the AT&T 54016 ESF mode or SF mode. The user can view these registers, but cannot reset the data. The 'R' in the command string is used to gather remote error history information if desired.

Entering	Displays
(R)PC1	the ESF error count.
(R)PC2	to request the 1-hour performance report.
(R)PC3	to request the 24-hour ES report
(R)PC4	to request the 24-hour BES report.
(R)PC5	to request the 24-hour SES report.
(R)PC6	to request the 24-hour UAS report.
(R)PC7	to request the 24-hour CSS report.
(R)PC8	to request the 24-hour LOFC report.

User Performance History

The User Error History Menu allows for displaying the user error history options when AT&T 54016 ESF mode or SF mode is selected. The 'R' in the command string is used to gather remote error history information if desired.

- | | |
|----------|---|
| Entering | Displays |
| (R)PU0 | the ESF error count. |
| (R)PU1 | the previous 1-hour accumulation of error data. |
| (R)PU2 | to display the previous 24-hour accumulation of errored seconds. |
| (R)PU3 | the previous 24-hour accumulation of bursty errored seconds data. |
| (R)PU4 | the previous 24-hour accumulation of Severely Error Seconds data. |
| (R)PU5 | the previous 24-hour accumulation of unavailable seconds data. |
| (R)PU6 | the previous 24-hour accumulation of control slip seconds and loss of frame count data. |
| (R)PU7 | to reset the performance monitoring counters. |
| (R)PU8 | to reset the errored ESF counter. |

REMOTE FT 100S CONFIGURATION The FT 100S has the capability of configuring a remote FT 100S or FT 100 using the ESF Facility Data Link and a proprietary protocol. Remote configuration is accomplished through the use of the control port or LocalView. Since the ESF Data Link is utilized for this feature, the framing option on all units must be selected for "ESF".

The following is description of the various command strings used in remotely configuring an FT 100S or FT 100.

Configuration Control CRC

The choice for this option determines whether the information displayed for the various control port screens pertains to the local unit or remote unit. If the configuration control is selected for remote configuration, all the information displayed on the various option and summary screens shows the configuration of the remote unit at the time that its configuration was last downloaded (CR1 command). If the configuration control is selected for local configuration, the configuration information is that of the local unit.

Remote Configuration Mode CRM

The choice for this option determines which FT 100S or FT 100 may actually handle all of the configuration for both units. The FT 100S or FT 100 that is selected for slave mode may be configured from the master unit and request the configuration from the master unit but may not change it.

Get Remote Configuration CR1

This command initiates the actual downloading of the remote FT 100S or FT 100's configuration information. Once this is complete, the option and summary screens for the remote unit may be viewed by selecting the configuration control on the local unit for remote configuration.

**Send Remote
Configuration
CR2**

This command initiates actual transmission of the configuration information across the data link to the remote FT 100S or FT 100.

Note: The remote FT 100S or FT 100's configuration is not actually updated until this command is successfully executed.

When changes are made to the various configuration options for the remote FT 100S or FT 100, they are stored in the local FT 100S. Therefore, that information must be sent across the network using this command before the remote unit reflects any of the changes made.

**Send Remote
Unit ID
CR3**

Sends the remote units ID across the data link after being determined and entered at the local unit.

**Send Remote
Password
CR4**

Sends the remote units password across the data link after being determined and entered at the local unit.

**Send Remote
Time and Date
CR5**

Sends the remote units time and date across the data link after being determined and entered at the local unit.

Chapter 7 Maintenance

***Warning:** Disconnect ac/dc power before performing maintenance. Although dangerous voltage levels are not exposed, disconnecting power will ensure an electric shock hazard is not present.*

GENERAL

The unit contains no electronic components that can be serviced or replaced by the user. Repairs should not be attempted by the user.

FUSE

If the ac power fuse or the external power input fuse fails, replace it with one of equal rating. Repeated failure indicates a more serious problem. If this happens, refer to the section on maintenance.

MAINTENANCE

The unit provides maintenance free service. Periodically it is necessary to remove dust that has collected on internal components. Remove dust with a soft bristle brush and low pressure air or vacuum.

Before attempting diagnostic tests, check that all connectors and plugs are firmly inserted. The test procedures will identify the faulty component in a bad communications link.

If the unit appears faulty, contact the UDS Field Service Department at 1-800-221-4380 for service and assistance. Do not return the unit without prior instructions.

Appendix A Specifications

NETWORK INTERFACE

Line Rate	1.544 Mbps \pm 75 bps
Line Code	Bipolar, AMI or B8ZS
Input Signal	+3.5 dBDSX to -34 dBDSX
Output Signal	DSX-1 w/LBO
Transmit LBO	Selectable 0, 7.5, 15 dB
Receive LBO	Automatic
Impedance	100 ohms nominal
Framing	SF or ESF
Jitter Tolerance	Per AT&T pub 62411
Connector	RJ48C 8-pin modular jack

NETWORK LOOPBACK CODES

Set Code	10000 per AT&T pub 54016
Reset Code	100 per AT&T pub 54016
Detection Time	5 secs per AT&T pub 54016

DTE INTERFACE

Data Port Configuration	V.35 or RS-530/449
Data Rates	n x 56 kbps or n x 64 kbps (n=1 to 24 DS0 time slots) =from 56 kbps to 1.536 Mbps
Electrical	V.35 or RS-530/449
Connector	25-pin D-type female, adapters available

CONTROL PORT

Electrical	RS-232
Rate	300 to 19200 bps, asynchronous, 8 bit data, no parity
Connector	9-pin D-type male connector, IBM PC/AT PC compatible

POWER SUPPLY

Power Source	115 Vac
Power Consumption	6 watts, typical

MECHANICAL

Dimensions	Shelf module - 9.5" x 6.3" x 0.9" Single unit housing - 10" x 7" x 2"
-------------------	--

ENVIRONMENTAL

**Operating
Temperature** 0 to 50 deg C

**Storage
Temperature** -40 to 70 degrees C

Relative Humidity 0 to 95% noncondensing

Appendix B

Control Port Command Quick Reference

Control Port Commands	Option	Menu Location	Page
/	Accesses sign-on screen		6-10
M	Accesses main menu		6-11
CL	T1 line configuration	Main	6-11
CD	DTE port summary		
CDxx	DTE port xx configuration		
CC	Control port configuration		
CT	Update time and date		
DL	T1 line tests		
DDxx	DTE port xx tests		
PC	Carrier performance display		
PU	User performance display		
CLF	Framing	T1 line	6-13
CLL	Line code		
CLP	ANSI T1.403 PRM (performance report message)		
CLM	AT&T 54016 message		
CLT	Timing		
CDxxN	Number of DS0s	DTE port	6-16
CDxxR	DS0 rate		
CDxxG	DS0 grouping		
CDxxRP	Receive clock polarity		
CDxxS	Starting DS0		
CDxxTC	Transmit clock		
CDxxTP	Transmit clock polarity		
CDxxCT	CTS mode		
CDxxRS	RLSD mode		
CDxxDS	DSR mode		

Appendix B
Control Port Command Quick Reference

Control Port Commands	Option	Menu Location	Page
CDxxTM	TM mode	DTE port <i>cont.</i>	6-16
CDxxLL	LL mode		
CDxxRL	RL mode		
CCE	echo	Control Port	6-17
CTThh:mm:ss	time update		
CTDdd/mm/yy	date update		
DL1	T1 Local Loopback	T1 line tests	6-18
DL2	T1 Network Loopback		
DL3	T1 Loopbacks		
DDxx1	Local Terminal Loopback	DTE port tests	6-19
DDxx2	Remote Terminal Loopback		
DDxx3	Remote Loopback		
DDxx4	Remote Loopback with Test Pattern		
DDxx5	Test Pattern		
DDxx6	Port xx test		
(R)PC1	ESF error count	Carrier performance history	6-24
(R)PC2	1-hour performance		
(R)PC3	24 hour ES		
(R)PC4	24 hour BES		
(R)PC5	24 hour SES		
(R)PC6	24 hour UAS		
(R)PC7	24 hour CSS		
(R)PC8	24 hour LOFC		
(R)PU1	ESF error count	User performance history	6-25
(R)PU2	1-hour performance		
(R)PU3	24-hour ES		

Control Port Command Quick Reference

Control Port Commands	Option	Menu Location	Page
(R)PU4	24-hour BES	User performance history <i>cont.</i>	6-25
(R)PU5	24-hour SES		
(R)PU6	24-hour UAS		
(R)PU7	24-hour CSS		
(R)PU8	24-hour LOFC		
(R)PU9	24-hour LCVS		
(R)RU1	reset performance monitoring counters		
(R)RU2	reset ESF error counter		

Appendix C Abbreviations and Acronyms

GENERAL

This appendix contains terms commonly used in the data communications field.

A			
ABT	Abort Timer OR Answer Back Tone	CCITT	International Consultative Committee for Telegraph and Telephone
ac	Alternating Current	CCU	Communications Control Unit
ACK	Acknowledgment, positive	CD	Carrier Detect
ACR	Abort Call, Retry	CFICB	Call Failure Indication - Local DCE Busy
ACU	Automatic Call Unit	CFIDT	Call Failure Indication - No Dial Tone
A/D	Analog-to-Digital	CFINT	Call Failure Indication - No Answer Back Tone
ADD	Address Field	CFIRT	Call Failure Indication - Ringback Detected
ADDR	Address	Ch Gnd	Chassis Ground
AGC	Automatic Gain Control	CIC	Connect Incoming Call
ASCII	American Standard Code for Information Interchange (7 level)	CMOS	Complementary Metal Oxide Semiconductor
AT&T	American Telephone and Telegraph	CNX	Connect Complete
B		COM	Computer Output Microfilm
BC	Bearer Capability	CO	Central Office
BCD	Binary Coded Decimal	COS	Call Originate Status
BER	Bit Error Rate	CPE	Customer Premise Equipment
BERT	Bit-Error-Rate-Test (set)	CPH	Characters Per Hour
BIL LB	Bilateral Loopback	CPU	Central Processing Unit
Bit	Binary Digit	CR	Carriage Return
bps	Bits Per Second	CRC	Cyclic Redundancy Check
BSC	Binary Synchronous Communications	CRQ	Call Request
BUFF	Elastic Buffer	CSA	Canadian Standards Association
C		CSDC	Circuit Switched Digital Capability
C	Celsius	CSU	Channel Service Unit
CA	Circuit Assurance	CSULL	Channel Service Unit Local Loopback
CBX	Computerized Private Branch Exchange	CTRL	Control Field
CC	Carrier Control	CTS, CS	Clear to Send

D		EPROM	Erasable Programmable Read Only Memory
DAA	Data Access Arrangement (AT&T)	ER	Error
dB, db	Decibel	ESC	Escape (key)
dc	Direct Current OR Digital Connection	ETB	End of Block
DCE	Data Circuit Terminating Equipment OR Data Communications Equipment	ETC	External Transmit Clock
DCD	Data Carrier Detect	ETX	End of Text
DCPSK	Differentially Coherent Phase-Shift Keying	EXT	External
DDD	Direct Distance Dialing	F	
DDS	Digital Data Service OR Data- phone Digital Service (AT&T)	FA	Feature Activator
DDS/MR	Digital Data Service / Multi Rate	FB	Fallback
DIC	Disregard Incoming Call	FCC	Federal Communications Commission
Dip	Dual In-line Package	FDM	Frequency Division Modulation
DIS, DS	Disable	FDX	Full-Duplex Transmission
DLE	Data Link Escape	FF	Form Feed
DLO	Data Line Occupied	FGND	Frame Ground
DMS	Digital Multiplexer System	FL	Flag
DOC	Department of Communications (Canada)	FLL	Fixed loss loop
DOS	Disk Operating System	FM	Frequency Modulation
DPR	Digit Present	Fox message	Test message (The quick brown fox jumps over the lazy dog) 0123456789
DRS	Data Rate Select	FSK	Frequency-Shift Keying
DSR	Data Set Ready	FX	Foreign Exchange
DSU	Data Service Unit	H	
DTE	Data Terminal Equipment	HDLC	High Level Data Link Control
DTMF	Dual Tone Multi Frequency	HDX	Half-Duplex Transmission
DTN	Dial Tone Detected	Hz	Hertz (cycles per second)
DTR	Data Terminal Ready	I	
E		INC	Incoming Call
EBCDIC	Extended Binary Coded Decimal Interchange Code (8 level)	INV	Invalid
EIA	Electronic Industries Association	INVCU	Invalid Command - Command Unknown
EIA-232C, EIA-232D	Interface between DTE and Data Interchange Communication Equipment employing serial binary data	INVMS	Invalid Command - Message Syntax Error
EN	Enabled	INVPS	Invalid Command - Parameter Syntax Error
ENQ	Enquiry	INVPV	Invalid Command - Parameter Value Error
EOA	End of Address	I/O	Input / Output
EOM	End of Message	IS	International Standard
EON	End of Number	ISDN	Integrated Services Digital Network
EOT	End of Text OR End of Transmission		

K		O	
KBD	Keyboard	OH	Off Hook
kbps	Kilobits Per Second	OS	Out-of-Service
L		P	
LAL	Local Analog Loopback	PBX	Private Branch Exchange
LAPD	Link Access Protocol - D Channel	PC	Personal Computer
LAPM	Link Access Protocol for Modems	pc	Printed circuit (board)
LB OPTS	Loopback Options	PIW	Power Indication
LCD	Liquid Crystal Display OR Line Current Disconnect	PN	Pseudo random
LDL	Local Digital Loopback	PND	Present Next Digit
LDM	Limited-Distance Modem	POTS	Plain Old Telephone Service
LED	Light Emitting Diode	PRI	Primary
LF	Line Feed	PRO	Program Option
LINK	Analog Telephone Line Connection	PROG, PR	Programmable
LL	Local Loopback	PROM	Programmable Read Only Memory
LO	Line Occupancy	PRP	Restored Factory Straps
LRC	Longitudinal Redundancy Check	PR/TM	Power / Test Mode / Error
LSD	Long Space Disconnect	PSK	Phase Shift Keying
LSI	Large-Scale Integrated (circuit)	PSTN	Public Service Telephone Network
LSO	List of Stored Options	PWI	Power Indication
LSV	List Version	Q	
LT	Loop or Link Termination	QAM	Quadrature Amplitude Modulation
M		R	
mA	Milliamps	R	Reference Designator
MHz	MegaHertz	RAD	Random Access Method
Modem	Modulator / Demodulator	RAL	Remote Analog Loopback
MR	Modem Ready	RAM	Random Access Memory
MR/RI	Modem Ready / Ring Indicate	RC	Receive Clock
ms	Millisecond	RCD	Receiver-Carrier Detector
MUX	Multiplexer	RCV, RCVR	Receiver
N		RD	Receive Data
NAK	Negative Acknowledgment	RD/ER	Receive Data / Error
NET STAT	Network Status	RDI	Receive Data Inhibit
NRZ	Non Return to Zero	RDL	Remote Digital Loopback
NRZI	Non Return to Zero Inverted	RI	Ring Indication
NS	No Signal	RL	Remote Loopback
NT	Network Termination	RLO	Request List of Stored Options
		RLSD	Received Line Signal Detector
		RLV	Request List of Version

rms	Root-Mean-Square	UART	Universal Asynchronous Receiver / Transmitter
RMT LB	Remote Loopback	USOC	Universal Service Ordering Code
RNG	Ringback Detection		
RO	Receive Only		
ROM	Read Only Memory		
RT	Remote Terminal	V	
RTS, RS	Request to Send	V.	CCITT Code Designation
RX	Receive	V.24	List of definitions for interchange circuits between data terminal equipment and data circuit-terminating equipment (and provisional amendments, May 1977)
S		Vac	Volts Alternating Current
S or S/T	Reference Designator	VAC	Value Added Carrier
SCC	Serial (or Satellite) Communications Controller	VAL	Valid
SD	Send Data	Vdc	Volts Direct Current
SDLC	Synchronous Data Link Control (IBM)		
SGND, SG	Signal Ground		
SH	Switch Hook	W	
SIM SW CR	Simulated Switched Carrier	WATS	Wide Area Telecommunications Access Method (AT&T)
SNR	Signal / Noise Ratio		
SPID	Service Profile Identifier		
SQD	Signal Quality Detector	X	
SQM	Signal Quality Monitor	X.	CCITT Recommendation Designation
SS	Systems Status	XMIT	Transmit
STX	Start of Text	XOFF	Transmitter Off
SYN	Synchronization Character	XON	Transmitter On
		XTC	External Transmit Clock
T			
T	Reference Designator		
TA	Terminal Adapter		
TC	Transmit Clock		
TD	Transmit Data		
TE	Terminal Equipment		
TEI	Terminal Endpoint Identifier		
TELCO	Telephone Company		
TELSET	Telephone Set		
TM	Test Mode		
TP	Test Pattern		
TR	Terminal Ready		
TST	Test		
TTD	Temporary Text Delay		
TTL	Transistor-to-Transistor Logic		
TX	Transmit		
U			
U	Reference Designator		

Index

A

- Abbreviations, C-1
- Acronyms, C-1
- Alarm, 4-37, 6-19
- ANSI T1.403 ESF mode, 6-22, 6-23
- AT&T 54016 ESF mode, 6-22, 6-23

B

- Baud rate, 4-48
- Bit stuffing, 4-35

C

- Carrier performance history, 6-24
- Change a strap setting, 3-2
- Change a switch position, 3-2
- Connect the unit
 - to the DTE, 2-4
 - to LocalView, 6-10
 - to a modem, 6-10
 - to the network, 2-3
 - to a terminal, 6-9
- Control port, 6-1
 - commands, 6-1
 - configuration, 6-12, 6-17
 - options, 4-46
- Cover removal, 3-1, 3-2
- CTS signal, 4-42

D

- Diagnostic test, 4-9
- Dip switch, 3-4, 3-5
- DSR signal, 4-43
- DTE configuration, 6-16
- DTE port test, 4-15, 6-19
 - local terminal loopback, 4-16
 - remote loopback, 4-19
 - remote terminal loopback, 4-16
 - test pattern, 4-23
- DTE status, 4-8

E

- Error conditions, 6-19
- Error events, 4-29, 6-20
- ESF framing, 6-14

F

- Front panel, 1-4

L

- LEDs, 5-1
- Line loopback, 4-36
- Line status, 4-6
- LL signal, 4-44
- Local echo, 4-48
- LocalView, 6-10

M

Main menu, 6-11
Maintenance, 7-1
Menu option table, 4-2, 4-3, 4-4

N

Network interface, A-1

O

Optional adapters, 2-8

P

Password, 4-49, 6-17, 6-27
Performance history, 4-28, 6-19
Pin functions
 control port, 2-4
 network connector, 2-3
 RS-530 / RS-449, 2-5
 V.35, 2-6
Port status, 4-6
Power, 2-8
 fuse, 7-1
 supply, A-2

R

Rear panel, 1-4
Remote configuration, 6-26
Remote CSU loopback, 4-13
Repairs, 7-1
RL signal, 4-45
RLSD signal, 4-43

S

Select DTE interface, 3-6
Self Test, 4-26
Set time and date, 4-50
Specifications, A-1
Strap application, 3-4

T

T1 line
 configuration, 6-11, 6-13
 local loopback, 4-10
 network loopback, 4-10
 options, 4-32
 test, 4-9, 6-12, 6-18
Time and date, 6-12, 6-18
TM signal, 4-44
Transmit clock polarity, 4-42
Transmit clock source, 4-41

U

Using the pushbuttons, 4-1

Toll Free Numbers

GENERAL

The following list of toll free numbers can quickly put you in touch with the service or party of your choice. Remember, at UDS, total customer satisfaction is only a phone call away.

Technical Support

800/221-4380 FAX: 205/430-7265

This number goes directly to our technical support staff. Please use it if you cannot identify or solve a technical problem with your UDS product.

Repairs

800/631-3946 FAX: 205/430-7042

Please call this number if it is determined that your UDS product has a malfunction that cannot be resolved by Technical Support or if you must return your product.

Switch-board

800/451-2369

This number connects you with one of our switch-board operators. Use it to obtain general information or for connection to any party or department desired.

Voice Mail

800/631-4869

The voice mail system can either connect you with the party of your choice or allow you to leave a detailed message. The clear operating instructions, quick response time, and multiple selections are designed to provide the caller with the utmost in convenience. The caller may enter the desired extension as soon as the operator answers, there is no need to wait.

- Marketing: Ext. 8410
- Sales: Ext. 8110
- Product Management: Ext. 8791
- International Sales: Ext. 8778
- Purchasing: Ext. 8241

WARRANTY

Motorola warrants that equipment manufactured and sold by us is free from defects in material and workmanship. Under this warranty, our obligation is limited to repairing or replacing any equipment or parts (not already carrying a separate warranty of their supplier) proved to be defective by our inspection within two years after sale to their original purchaser. This warranty shall not apply to equipment or parts thereof which are normally consumed in operation, or to any equipment which shall have been repaired or altered outside our plant in any way, so as to, in the judgment of Motorola, affect its stability or reliability, nor which has been operated in a manner exceeding its specifications, nor which has been altered, defaced, or has had the serial number removed. Motorola does not assume any liability for consequential damages and, in any event, our liability shall not exceed the original purchase price.

The foregoing constitutes the sole and exclusive remedy of the Buyer and exclusive liability of Motorola AND IS IN LIEU OF ANY AND ALL OTHER WARRANTIES EXPRESSED OR IMPLIED OR STATUTORY AS TO MERCHANTABILITY, FITNESS FOR PURPOSE SOLD, DESCRIPTION, QUALITY, PRODUCTIVENESS OR ANY OTHER MATTER. Without limiting the foregoing, in no event shall Motorola be liable for the loss of use or profit or other collateral, special or consequential damages.

TECHNICAL SERVICE - RETURNED EQUIPMENT AND PARTS

Motorola has instituted a toll-free WATS line for the technical support of our customers. The number is **1-800-221-4380** between 7:00 AM and 6:00 PM Central Time, Monday through Friday. Do not return any item without first calling the toll-free number to receive service or technical instructions. The toll-free number is direct to the technical services department. Please feel free to use it for technical information, application information, and modem/data communication fault isolation. **If the lines are busy, please call back.**

PLEASE CALL US. WE'RE HERE TO HELP YOU.

