

Results from the High-Resolution Fly's Eye (HiRes) Experiment

*Physics at the End of the
Galactic Cosmic Ray Spectrum
Aspen Apr 26-30, 2005*

Charles Jui (HiRes)
University of Utah

Outline

- Brief introduction of the High-Resolution Fly's Eye (HiRes) Experiment
- Energy spectrum
- Anisotropy
- Composition
- Proton-air cross-section measurement

The High Resolution Fly's Eye (HiRes)



HiRes Collaboration:

- *University of Utah*
- *Columbia University*
- *Rutgers University*
- *University of New Mexico*
- *University of Montana*
- *University of Adelaide*
- *Los Alamos National Laboratory (LANL)*
- *University of Tokyo*
- *IHEP (Beijing, China)*

HiRes Location

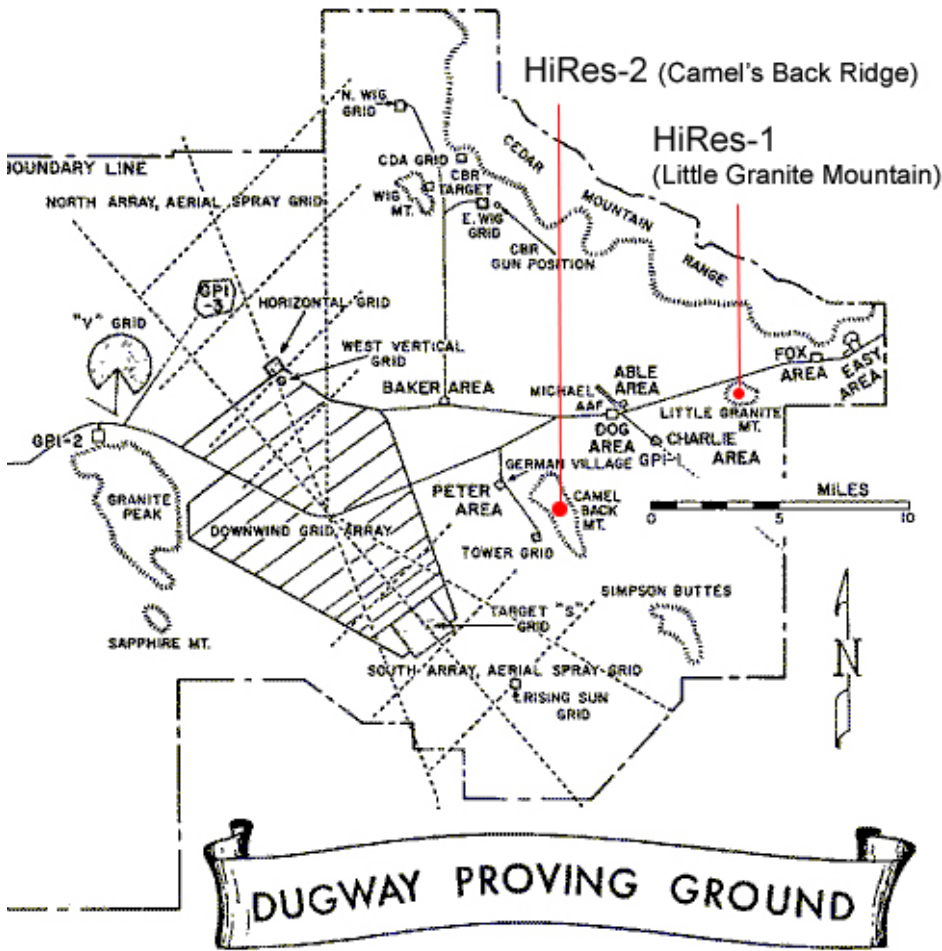

- HiRes is located on the U.S. Army Dugway Proving Ground, ~2 hours from The University of Utah campus.
- The two detector sites are located 12.6 km apart at Little Granite Mountain and Camel's Back Ridge

Detector Design

- Each HiRes detector unit (“*mirror*”) consists of:
 - spherical mirror w/ **$3.72m^2$** unobstructed collection area
 - 16x16 array (hexagonally close-packed) of PMT pixels each viewing **1° cone** of sky: giving $\times 5$ improvement in S:N over FE (5° pixels)
 - UV-transmitting filter to reduce sky+ambient background light
 - Steel housing (2 mirrors each) with motorized garage doors

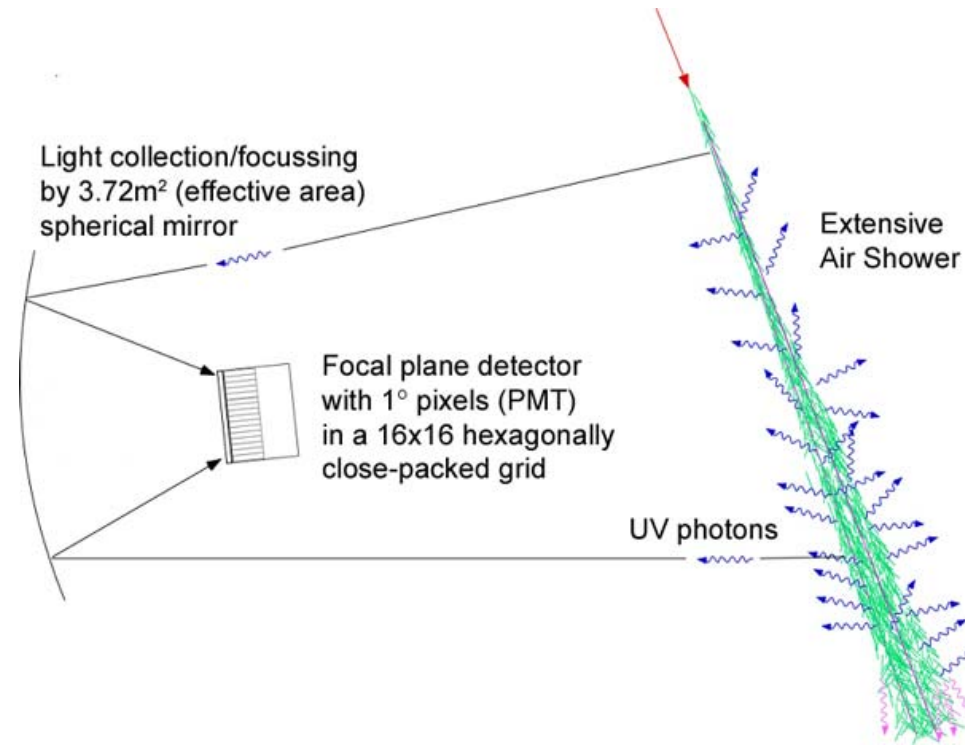

Typical HiRes Event

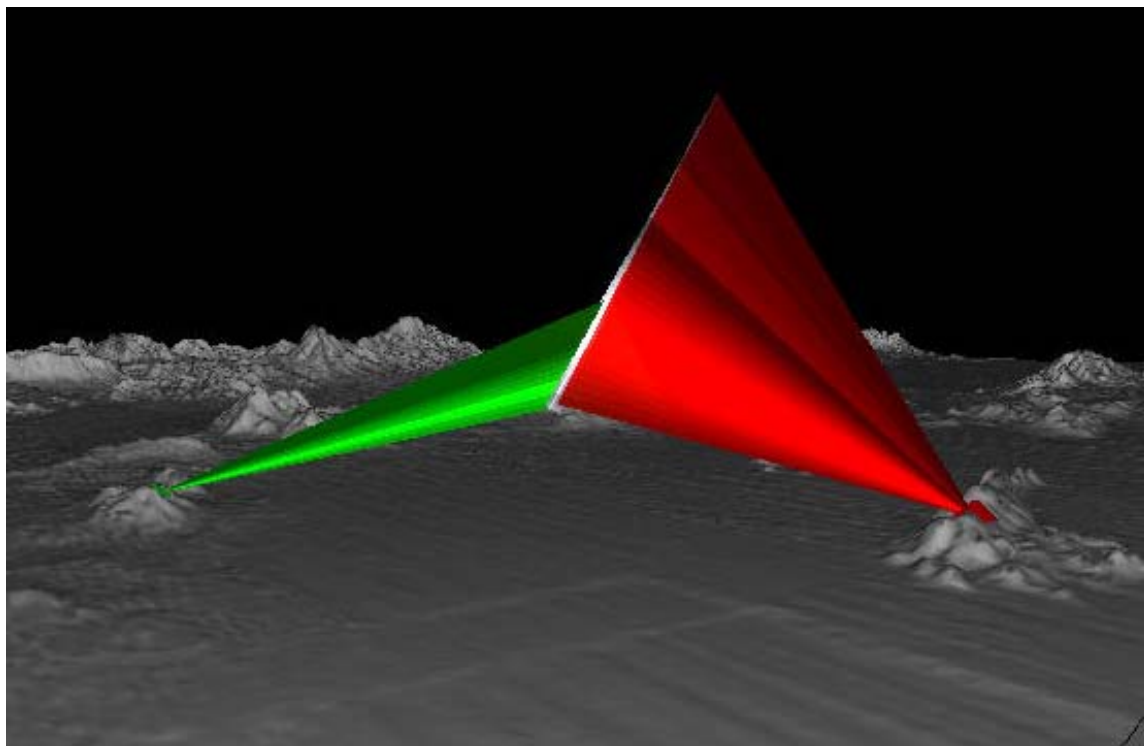

$\sim 2 \times 10^9 \text{ eV}$ event seen in 1999
($3 \times$ vertical scale)

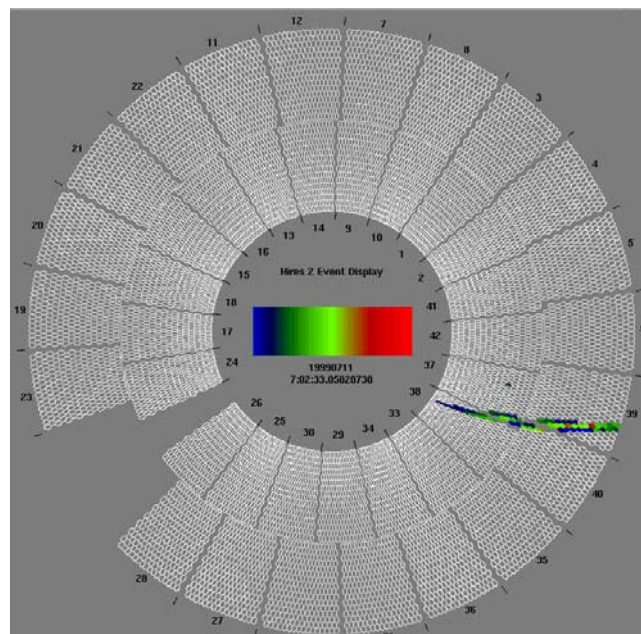
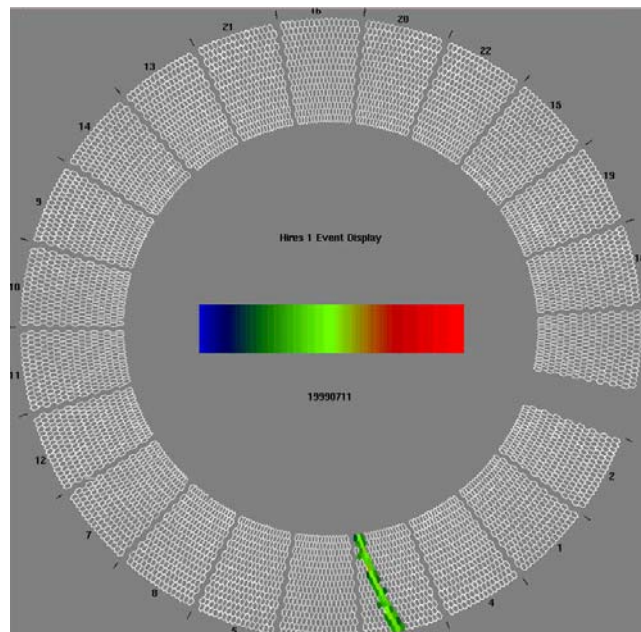

Reconstruction of EAS from HiRes Data

- The trajectory of the EAS can be determined in one of two ways:
 - Monocular reconstruction using the arrival time of light signal at the detector.
 - By intersecting the shower-detector planes (SDP) seen from the two detector sites.

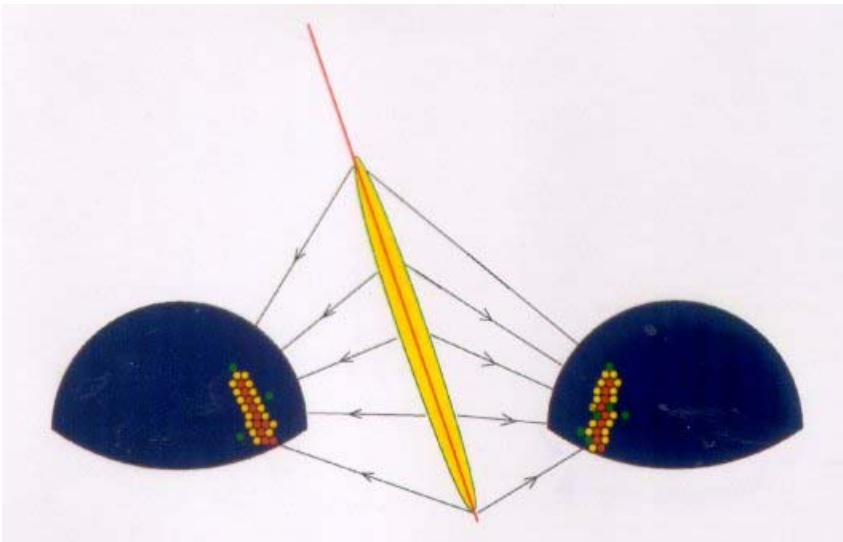

1.)

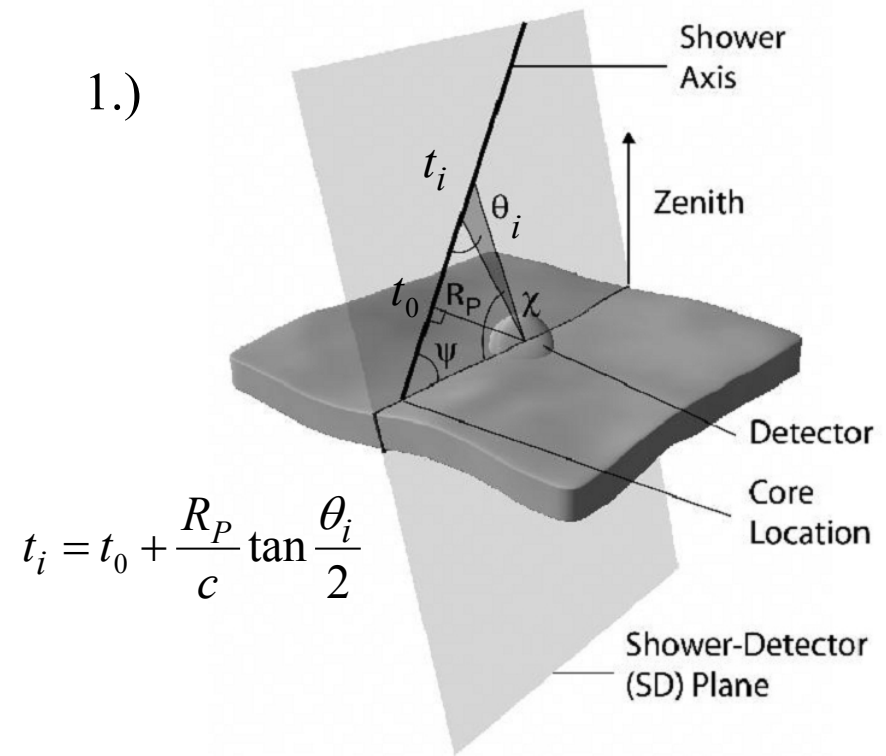

2.)

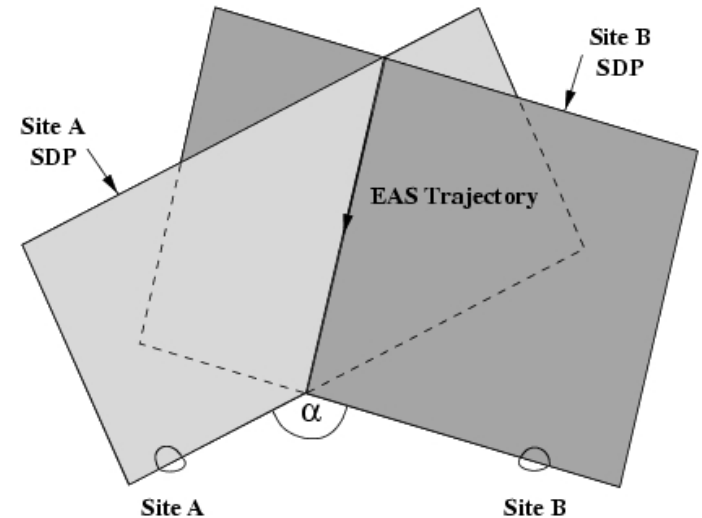

HiRes Operations

- Continuous operation of HiRes-1 detector since 1997 with 4 major down periods (7 months off after anthrax episode)
- Currently running at 10% duty cycle

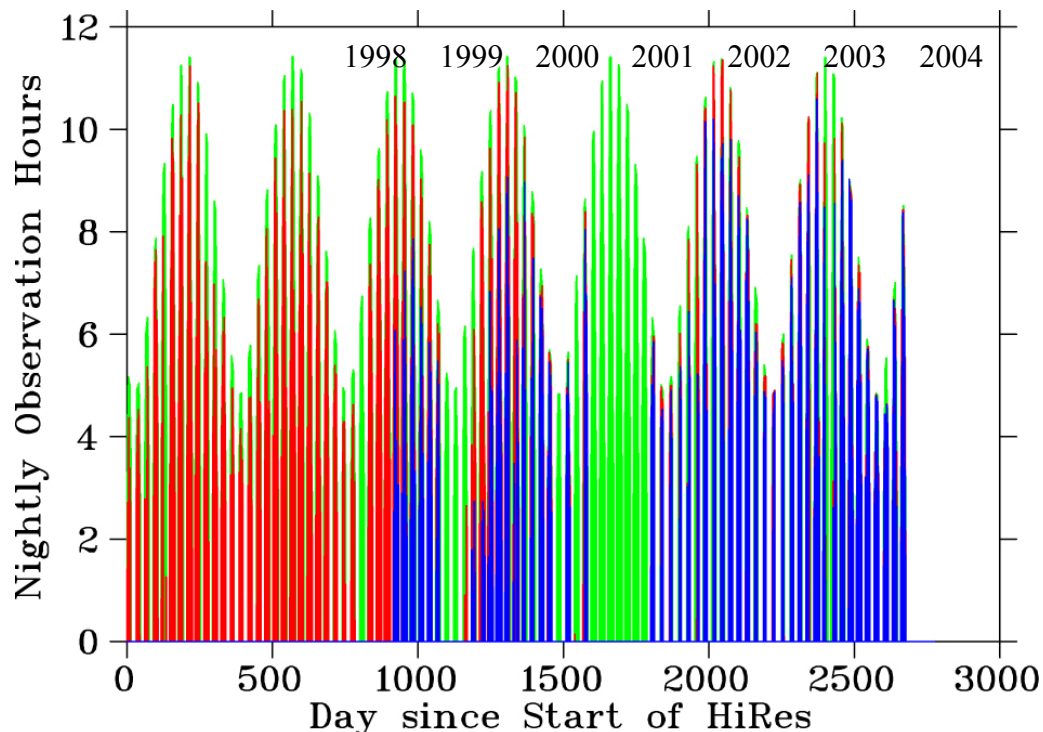

Experiment/ Data Set	Exposure (km ² sr-yr)
AGASA (100 km ²)	~1000
Fly's Eye (stereo)	150
Fly's Eye (monocular)	930
Haverah Park (12 km ²)	270
Yakutsk (25 km ²)	490
Total	2,740
HiRes-1 monocular	~5,000
HiRes Stereo	~2,500

Physics with HiRes Data

- **Stereo data**: best resolution, optimized for $E > 3 \times 10^{18} \text{ eV}$
- **HiRes-2 monocular**: can reach down to as low as $10^{17.2} \text{ eV}$
- **HiRes-1 monocular** data began ~ 3 years earlier: **largest statistics**,
 - Uses profile constrained fit (PFC) **unreliable** $< 10^{18.5} \text{ eV}$
 - No possibility of composition analysis with X_{max}

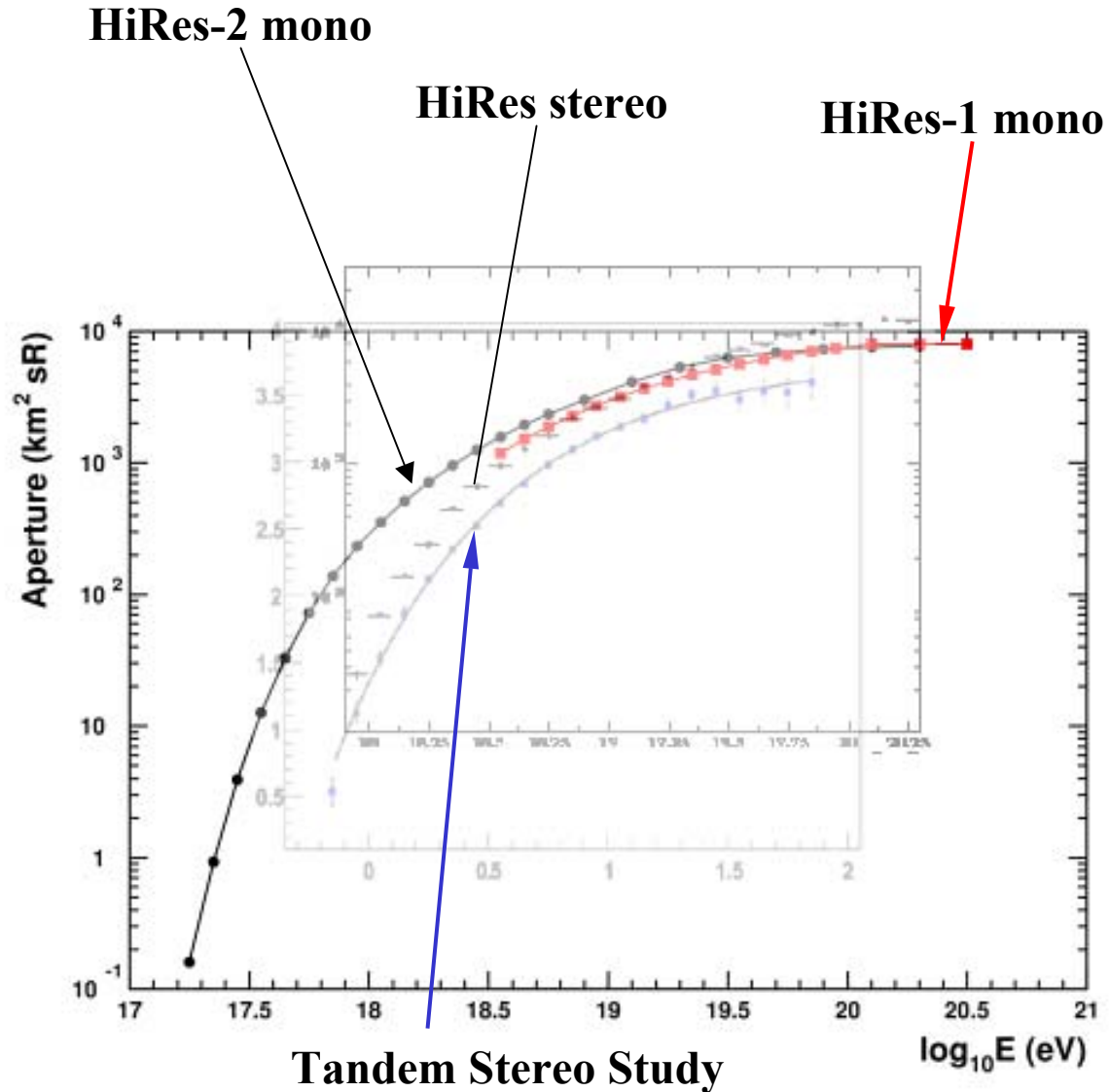

Monocular Spectrum

- HiRes-1 monocular requires “profile constrained Fit” (PCF)
- Combined HiRes-1 and HiRes-2 monocular spectra published:

Phys. Rev. Lett. 92, 151101 (2004)

- HiRes-2 monocular spectrum (updated Summer 2004)

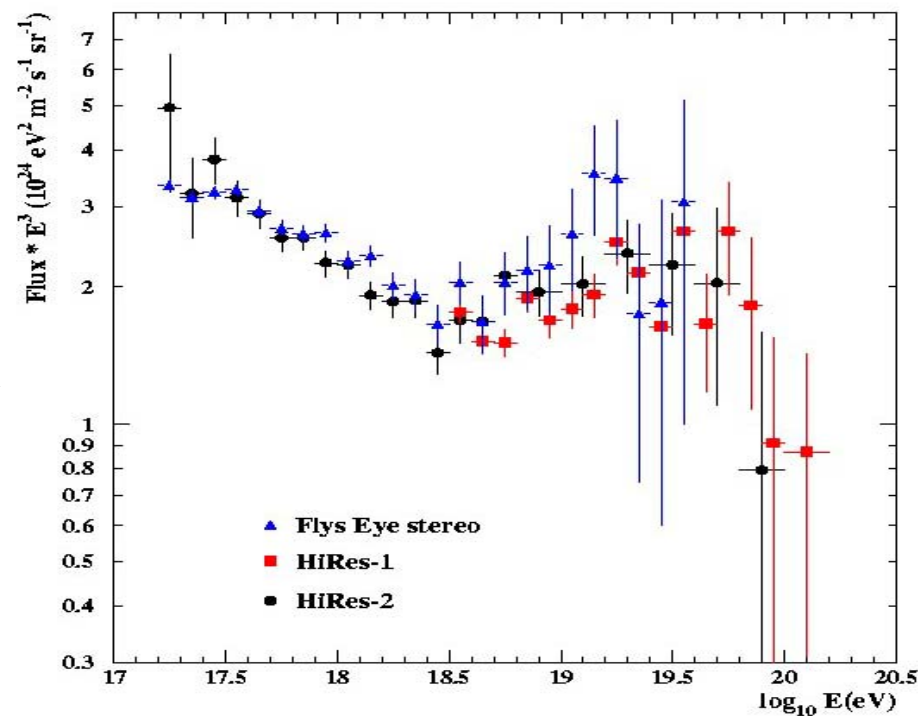
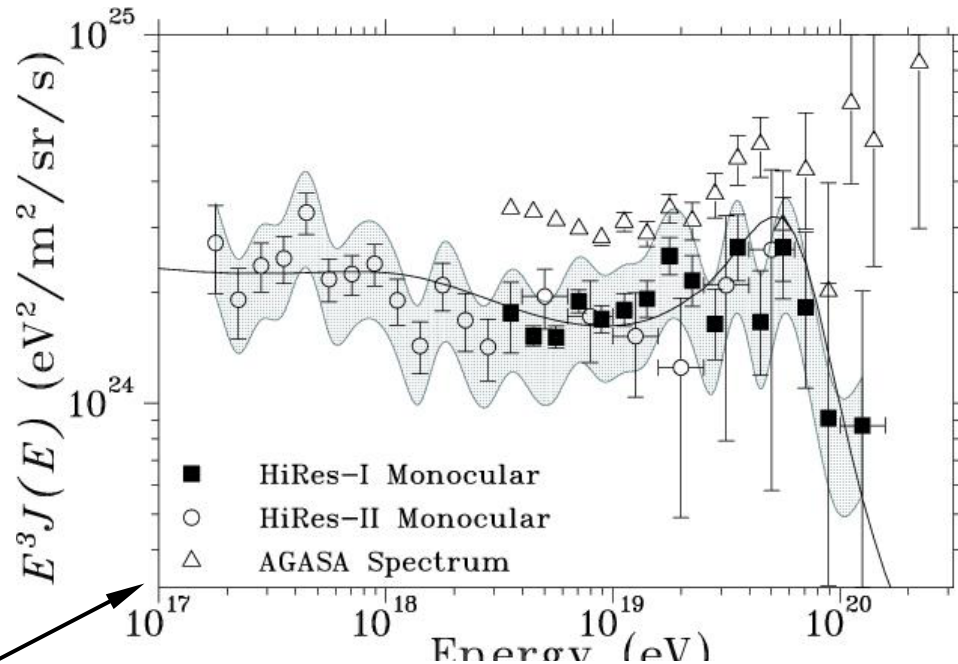

Cross checks

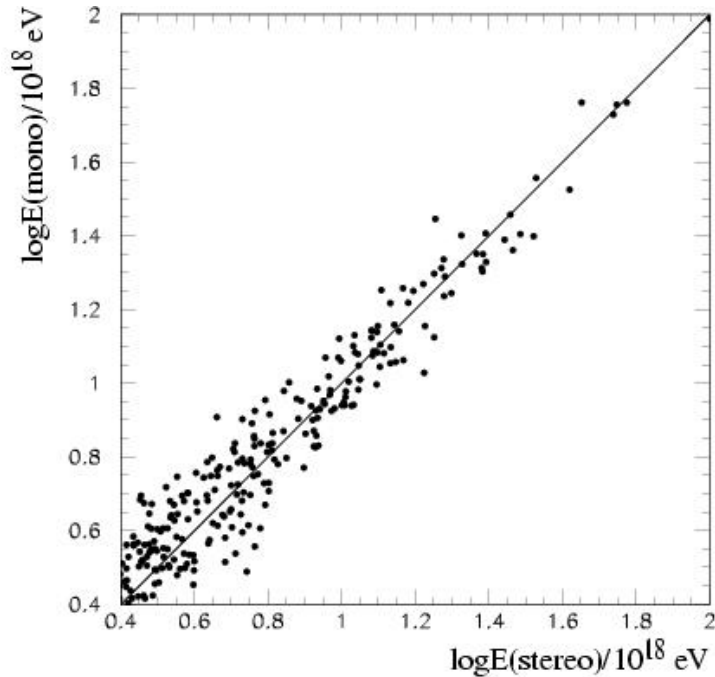

- PCF reconstruction and spectrum checked against:
 - stereo reconstruction
 - geometrically restricted aperture

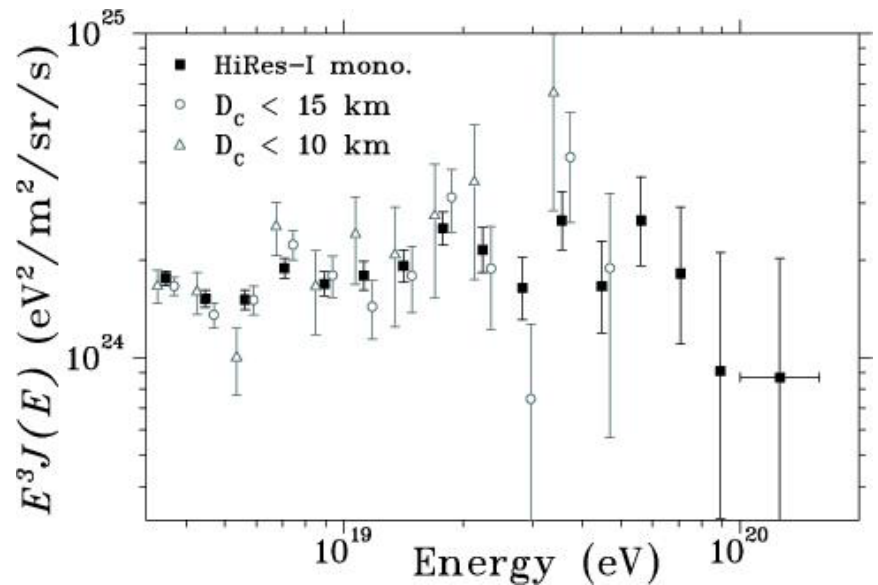
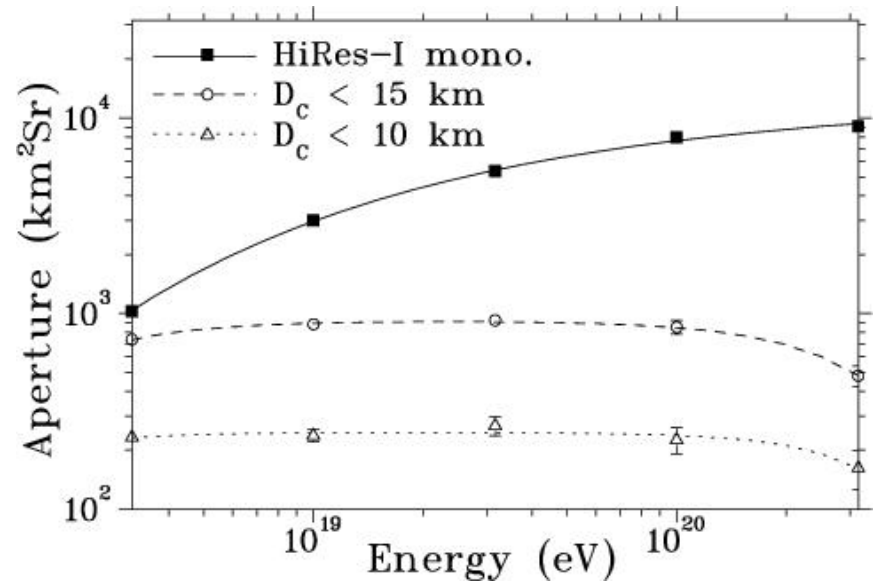

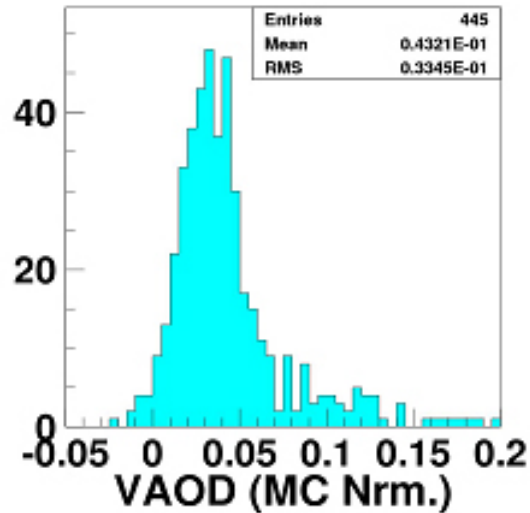

- Average Aerosol VAOD at Dugway ~0.04

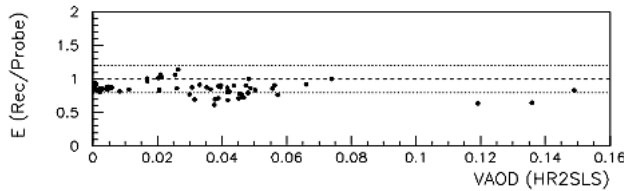
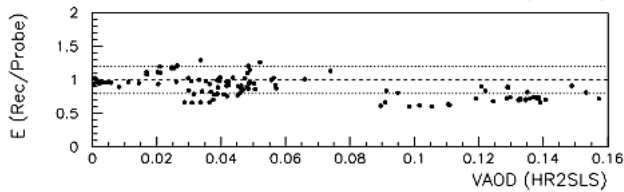
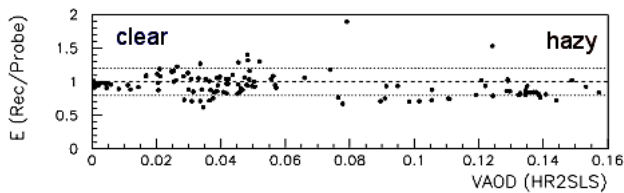

Energy Reconstruction of 34 km vertical Laser: Nov 2003 – April 2004

Cosmic Ray Light Balance Applied to Real Data

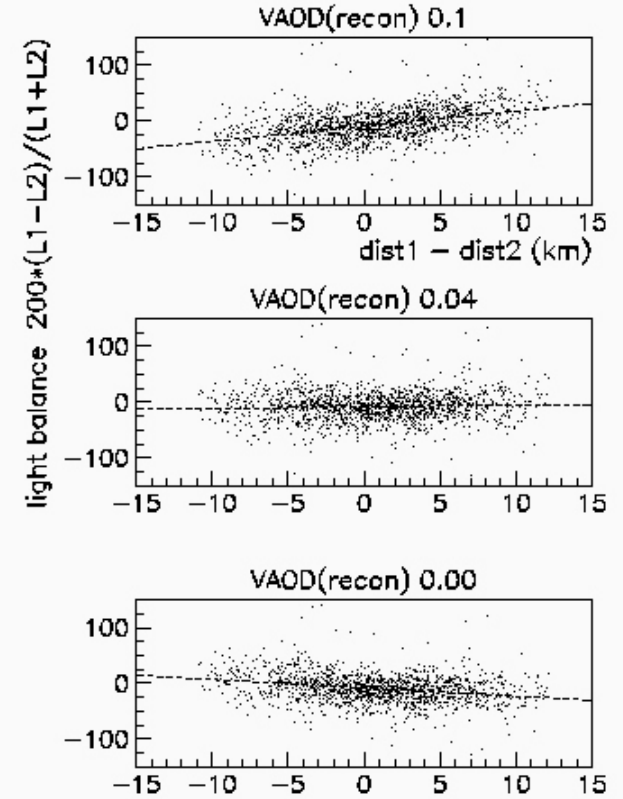

- Reconstructing energy of *vertical laser at 34 km* from HiRes-2 using hour-to-hour correction

FLASH (SLAC E-165)

- Undertaking detailed fluorescence measurements
- Also measure light yield from simulated showers (alumina)

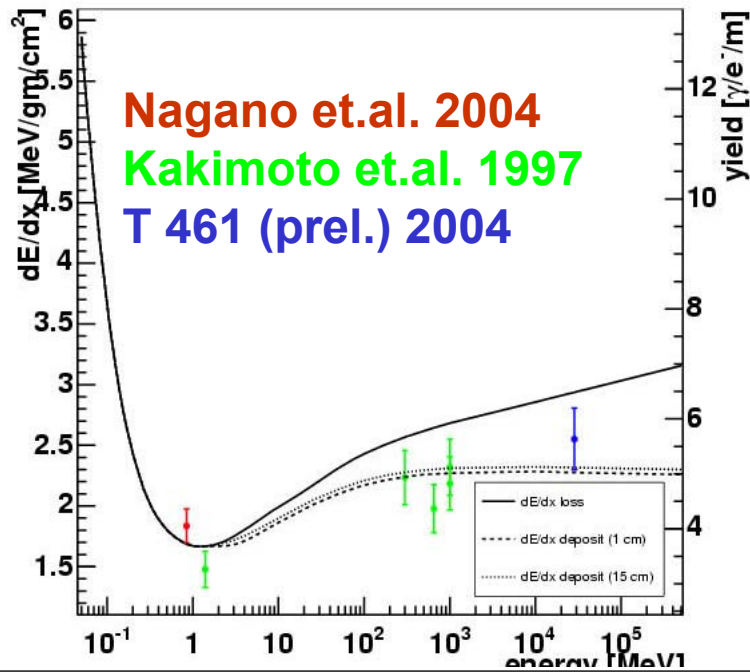

Spectrum In Dry Air Measured On North Side

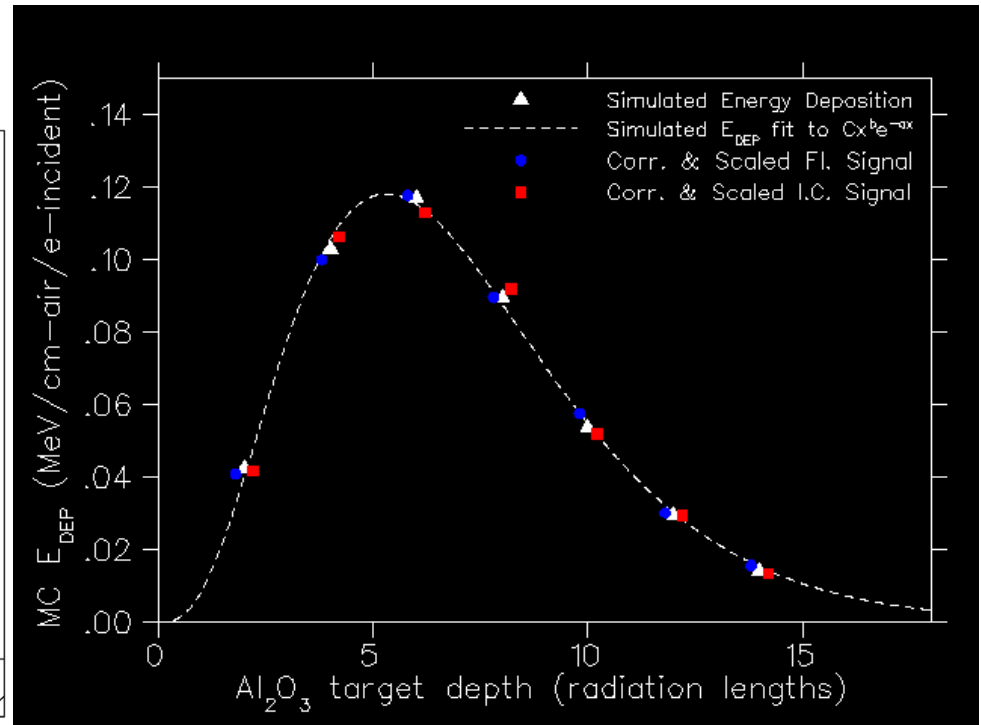
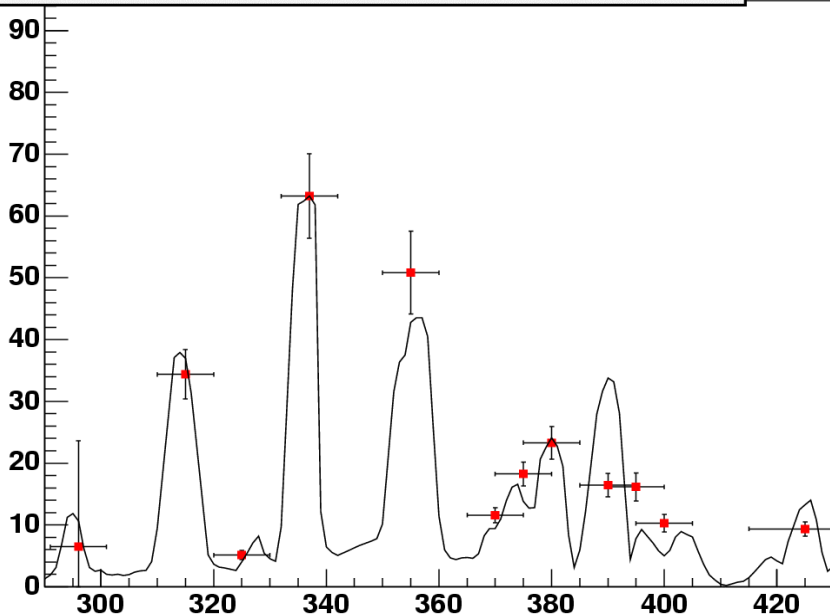

- Located west of the City of Delta: Now under construction
- TA Phase-1 (Standard TA)
 - Grond array of 576 (1.2km spacing) scintillation counters
 - Three fluorescence sites looking inward

Telescope Array Experiment

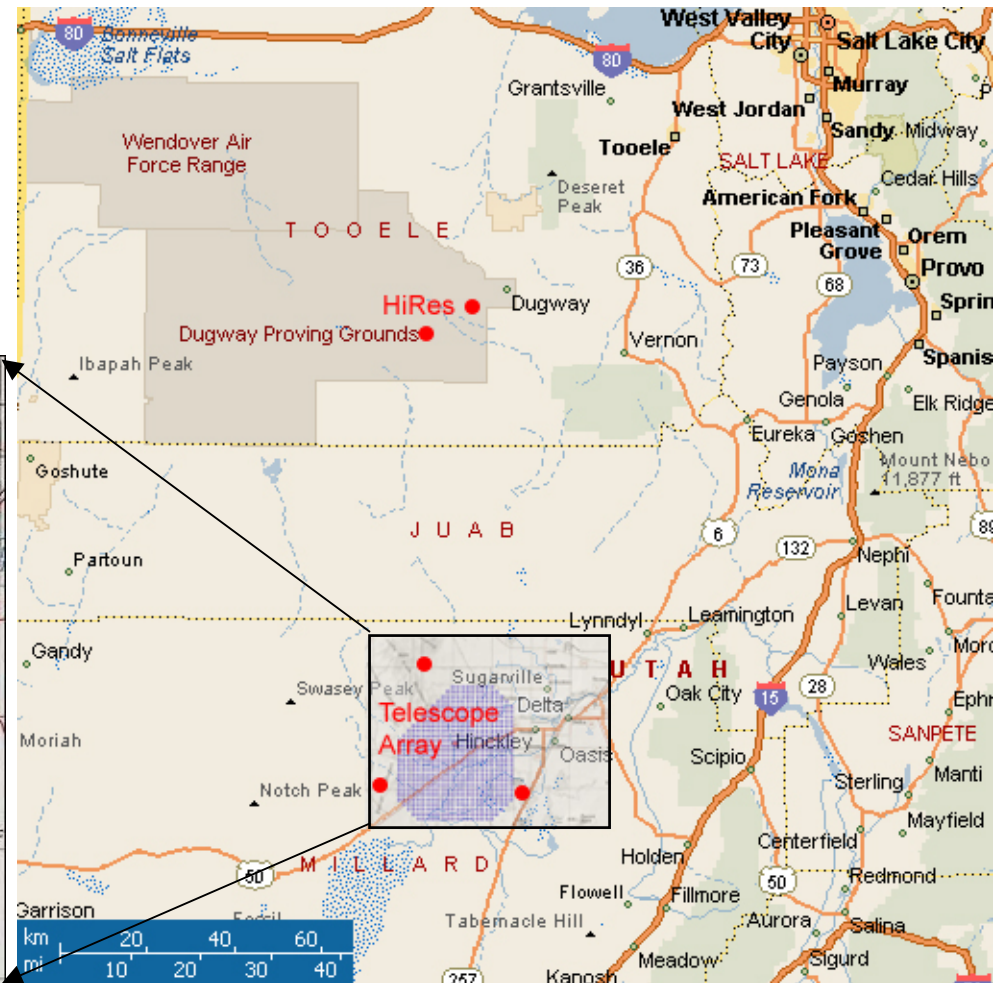
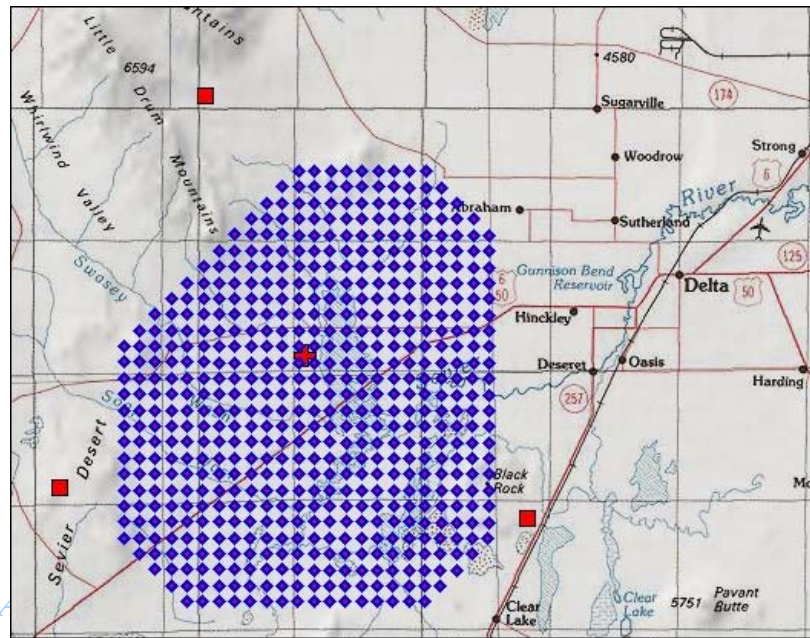

Power Law Fits

- Topic of another presentation later by Doug Bergman
- Triple Power Law Fit (TPLF)
 - Finds GZK suppression
- Hires-II sees the same features by itself:
 - Also finds GZK suppression

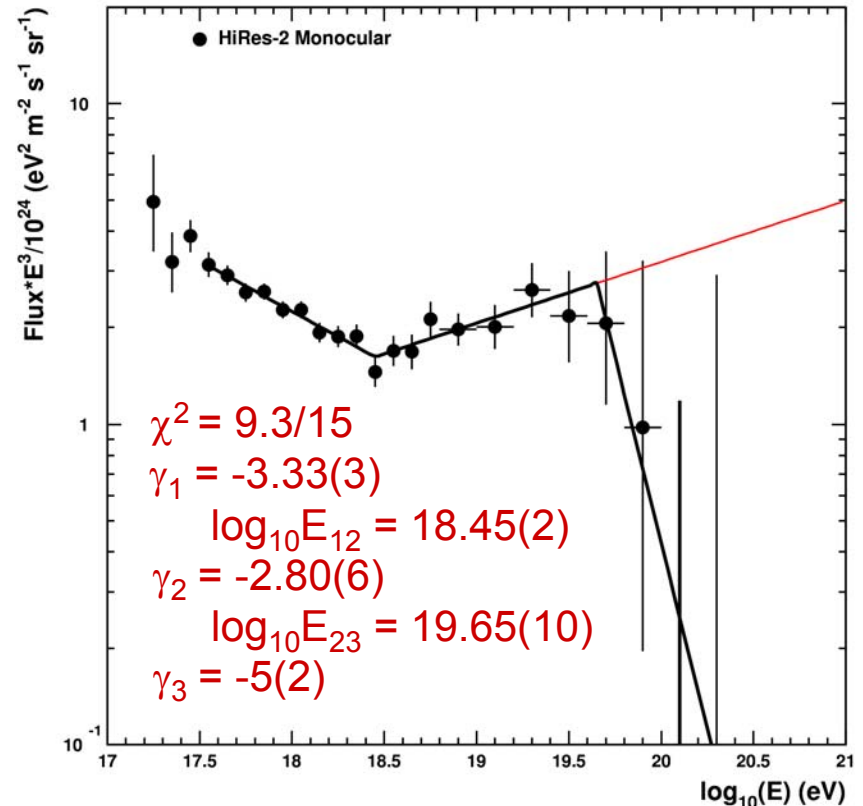
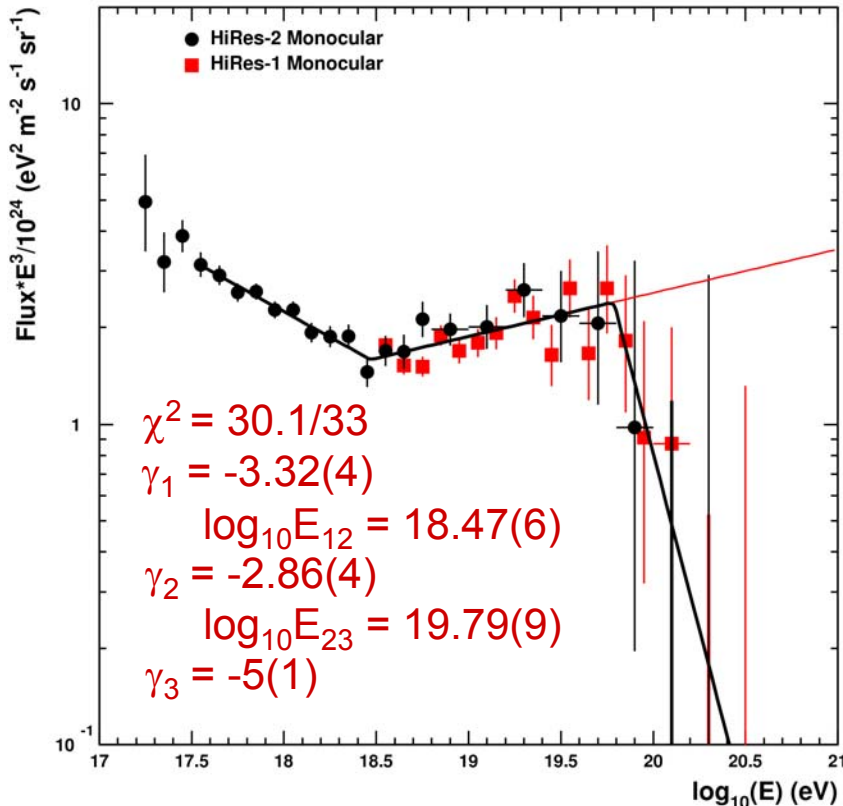

Monocular Spectrum Update

- Latest update HiRes-2 monocular spectrum continues to be in good agreement with HiRes-1 monocular in the region of overlap (which is expanding as more data is analyzed)

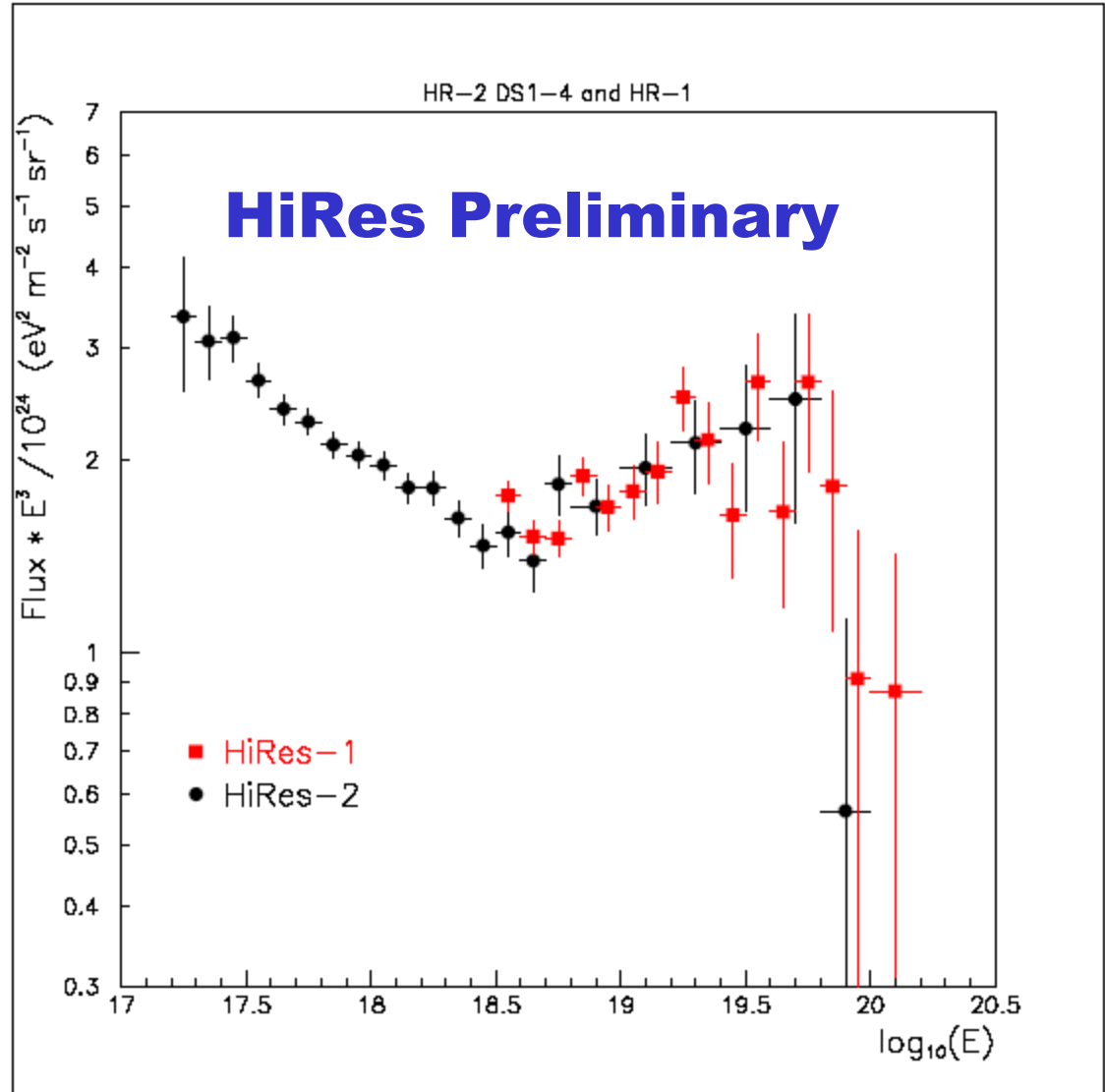

Monocular Anisotropy

- HiRes-1 mono ang. resolution: $\sim 8^\circ$ within the SD plane.
- Asymmetric error ellipses but with *area comparable to AGASA* angular resolution
- *Both are null results from HiRes*

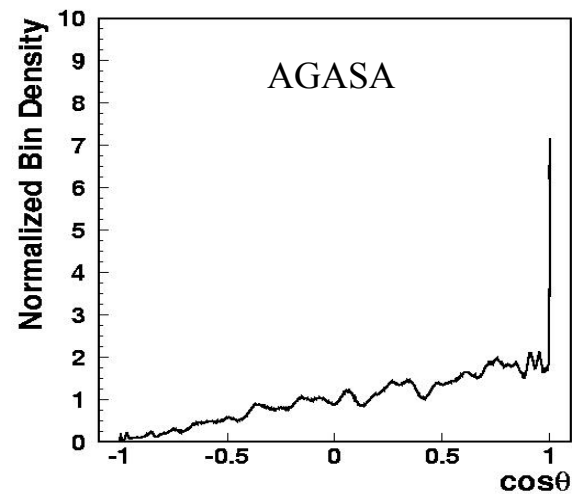
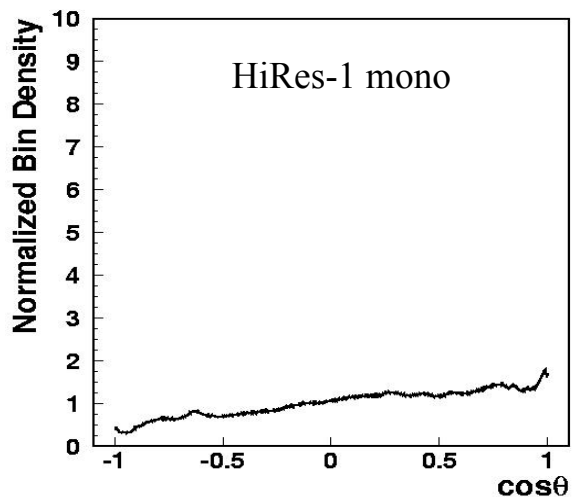

Autocorrelation functions (histogram of $\cos\theta$ between all possible pairs) for HiRes-1 monocular (left) and AGASA (right) events above $\sim 4 \times 10^{19}$ eV
Astropart. Phys. 22, 139 (2004)

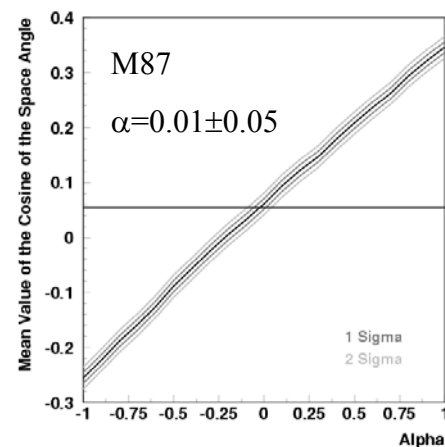
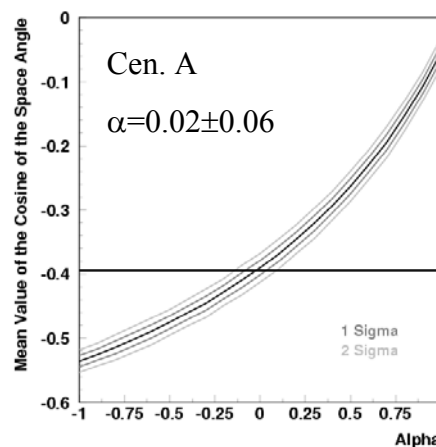
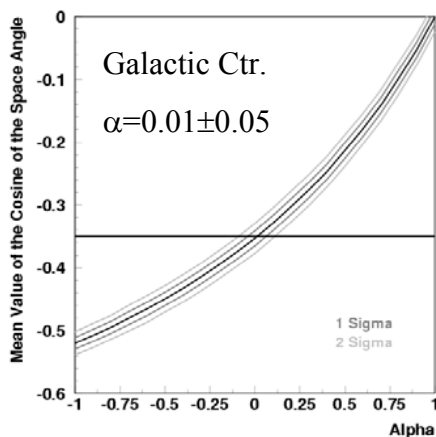

Search for dipole enhancement in the direction of nearby a-priori sources: *null results* for the *Galactic Center, Centaurus A, and M87*
Astropart. Phys. 21, 111 (2004)

Monocular Anisotropy

- Point source search: null result
- Search for cross-correlation with AGASA doublets and triplet:
 - treated the six AGASA “clusters” as *a priori* candidates
 - Observed overlap with these clusters is **no greater than that expected by chance** from an isotropic background
 - The fluctuation required for these sources to have yielded both the HiRes and AGASA event counts would occur with a **probability of less than 3%**.

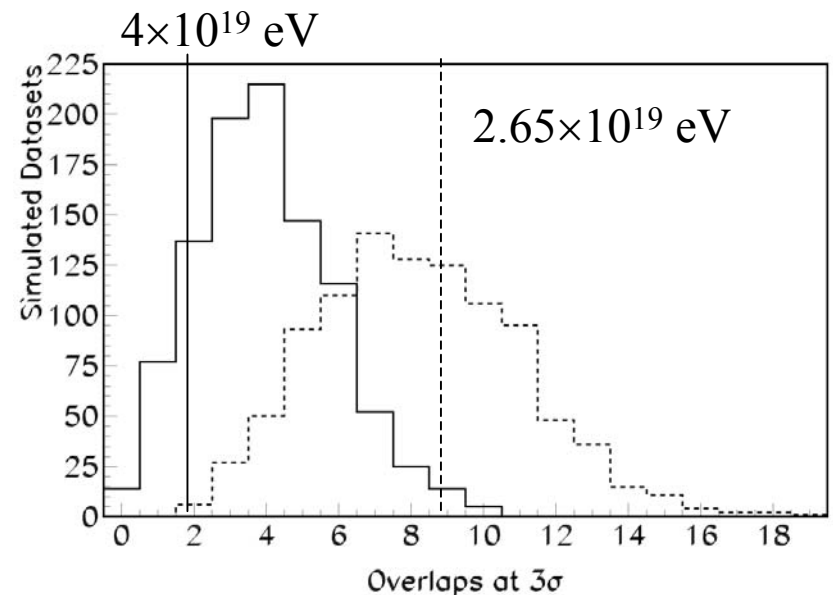
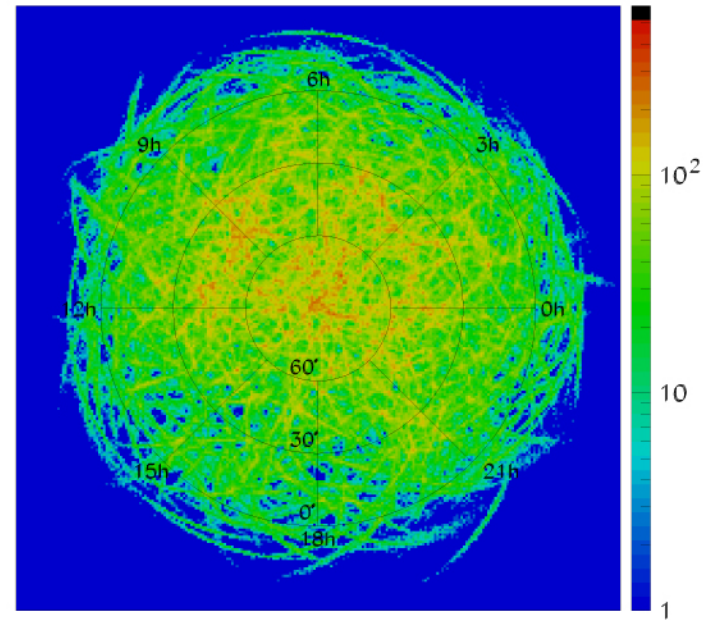

Prelim. Stereo Spectrum

- Stereo data has best energy resolution
- Statistics poorer than HiRes I monocular
- Present stereo data can be used to confirm the spectrum normalization from 3 to 100 EeV.
- Continue to accumulate Stereo Data to match monocular sensitivity at highest energies.
- New stereo spectrum by summer 2005

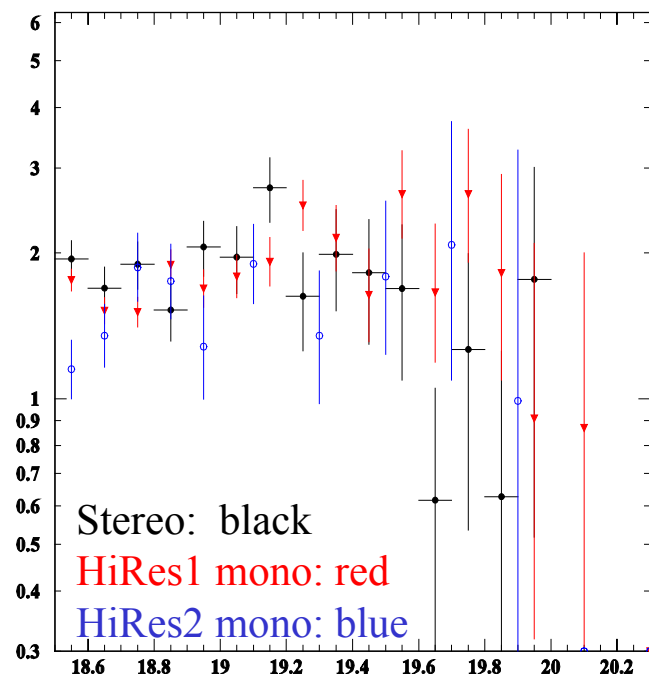
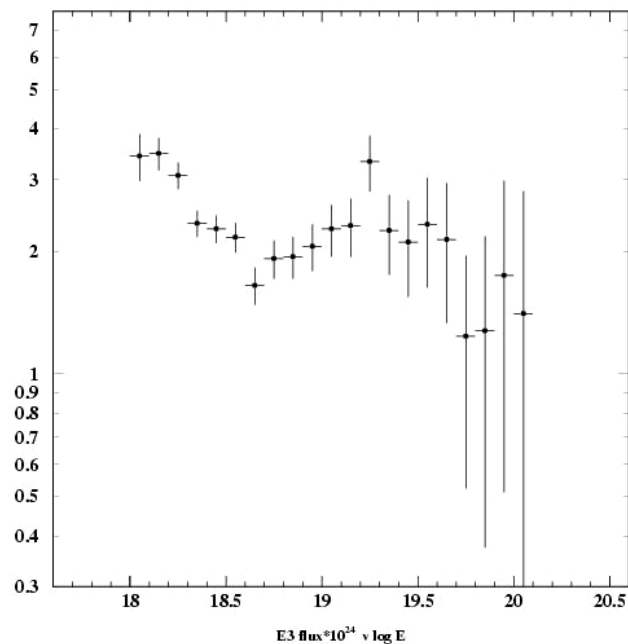

Stereo Anisotropy

- Stereo data has angular resolution *better than* **0.6°**: significantly better than that of AGASA

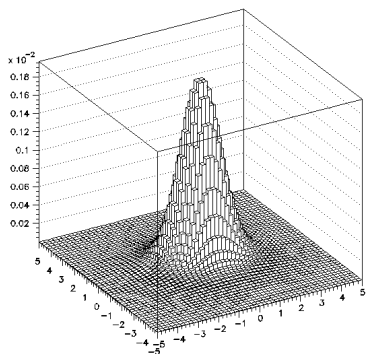
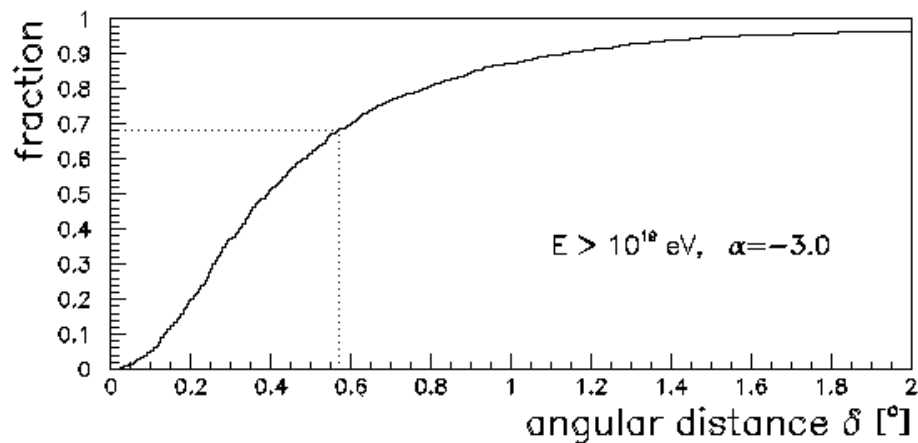

AGASA

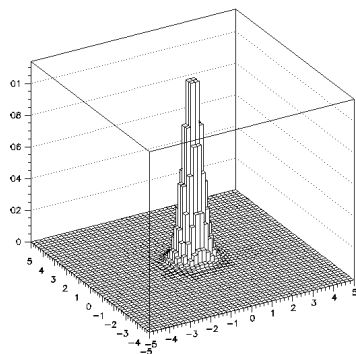

HiRes Stereo

68% Angular Resolution for AGASA and HiRes Events above 40 EeV

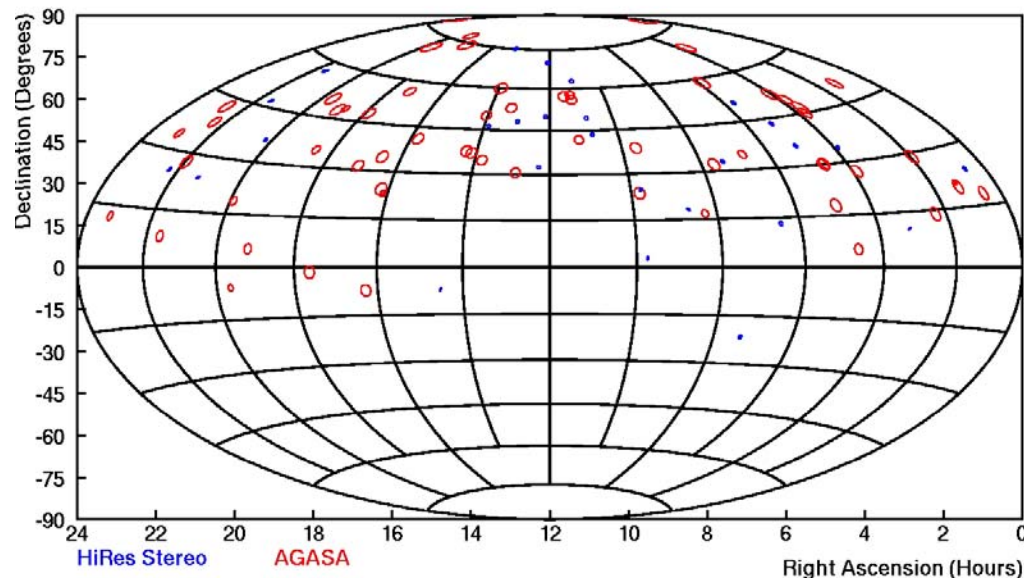

Stereo Anisotropy

- Analysis on small scale anisotropy:
- Count number of pairs N_p with separation $< \theta$.
- Use Monte Carlo with isotropic distribution to:
 - find probability of observing N_p
 - determine expected value for $\langle N_p \rangle$
- $w = N_p / \langle N_p \rangle - 1$
- HiRes ($E > 10^{19}$ eV) is consistent with isotropy at all small angular scales.
- **Astrophys. J. Lett. 610 (2004) L73**

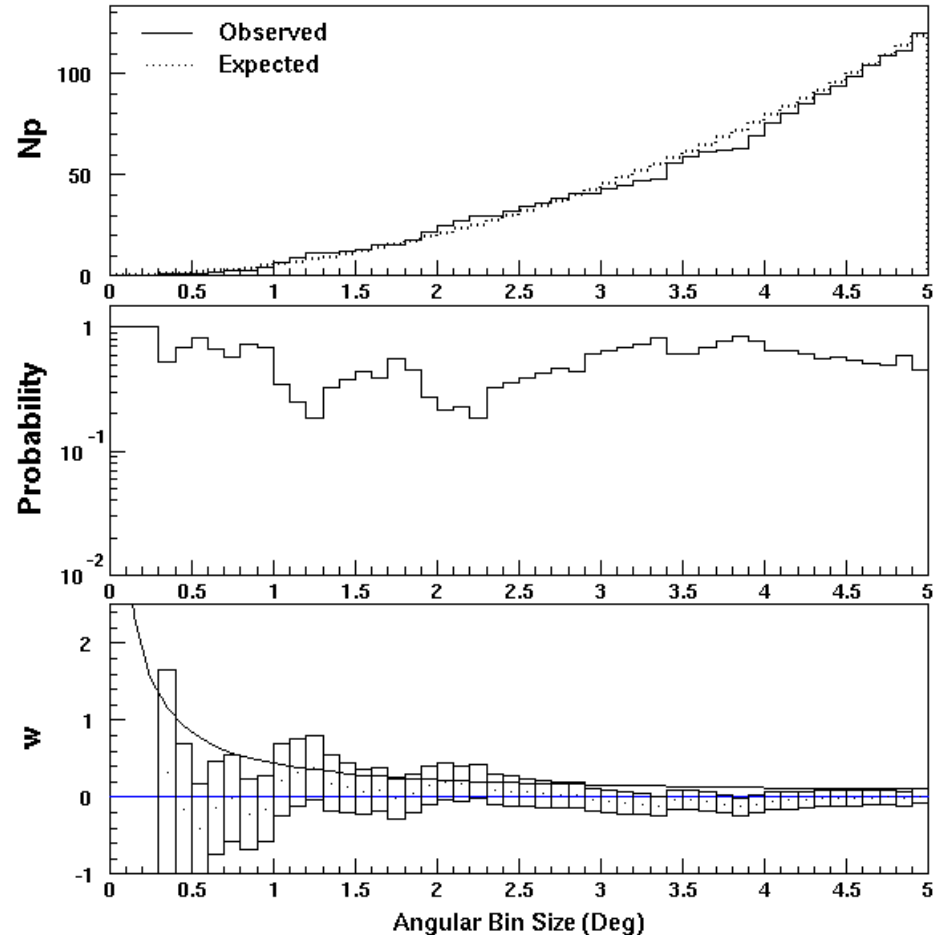

Stereo Anisotropy

- Work also in progress on search for enhancement about the Super-Galactic Plane
- Joint point source search with AGASA data
- Apply likelihood analysis to random isotropic data sets with identical number of events.
- 47 out of 10^4 have $\ln(R) > 12.98$.
- Actual chance probability is higher because of *ad hoc* changes in Hires threshold and *a posteriori* nature of the AGASA cuts.

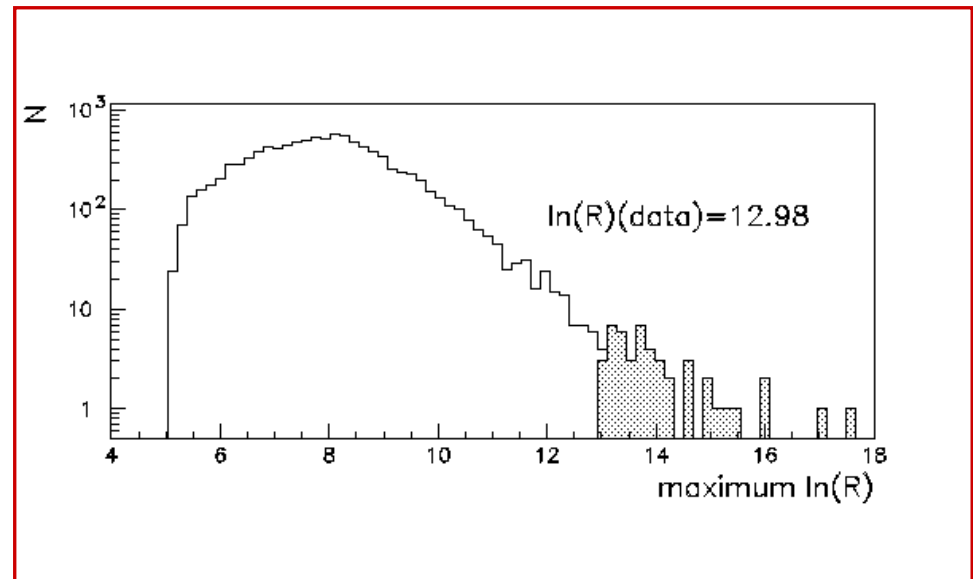
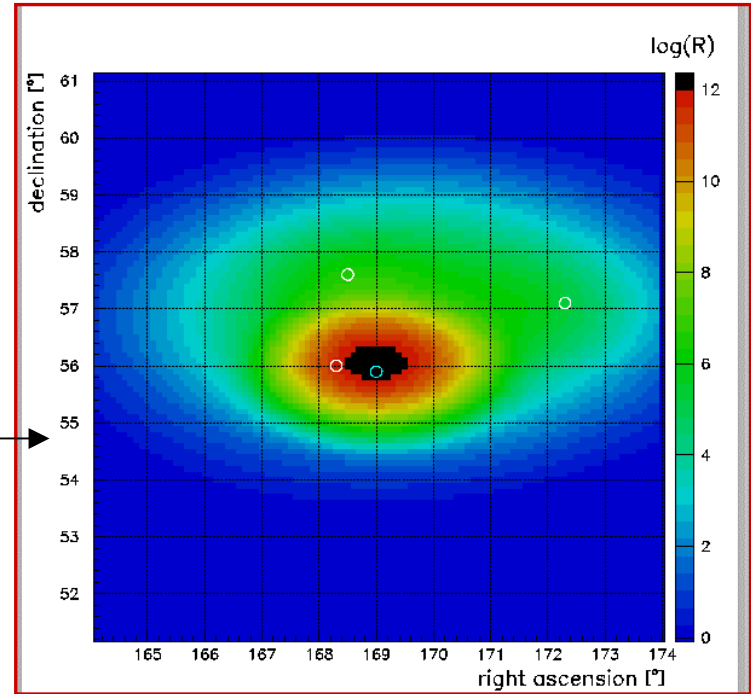

Stereo Anisotropy

- BL-Lac Correlations
 - **Gorbunov et al., astro-ph/0406654**
 - Set of 156 BL Lacs, with
 - no cuts on z , $m < 18$, no cuts on F_6
 - no criteria for correlation with EGRET catalog.
 - Set of HiRes events with $E > 10^{19}$ eV (271 events)
 - 11 events within 0.8° of these BL Lacs.
 - **chance probability $\sim 10^{-3}$**

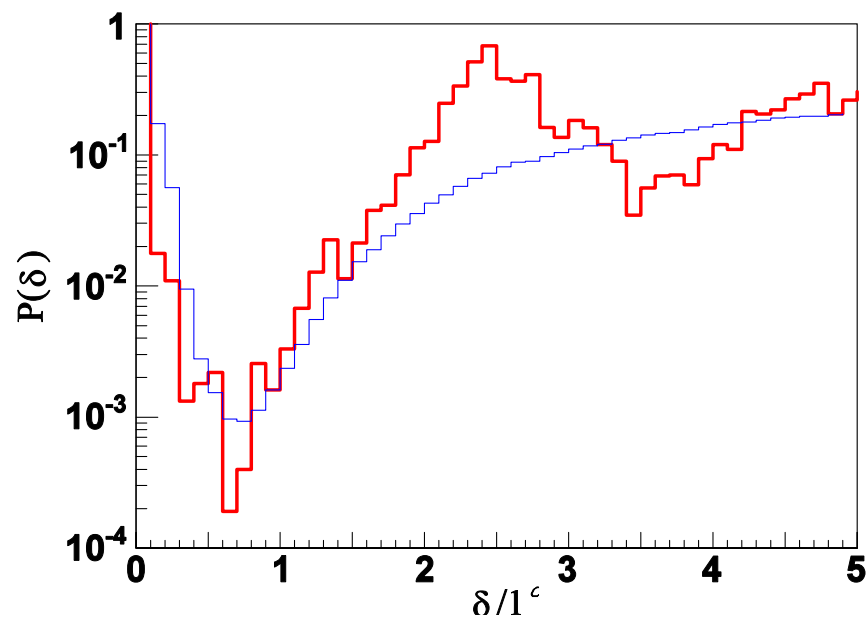
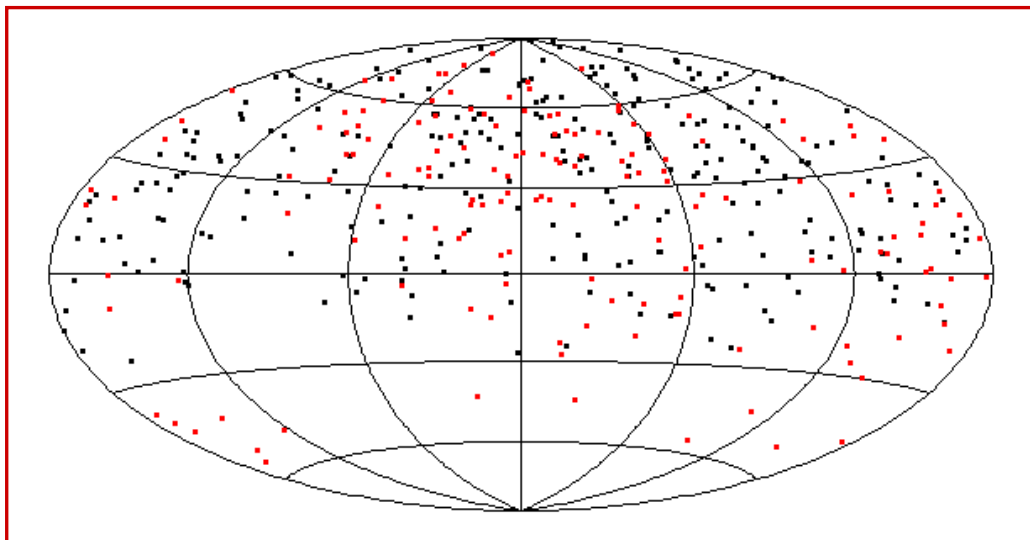

Composition

- **Astrophysical Journal 622 (2005) 910-926**

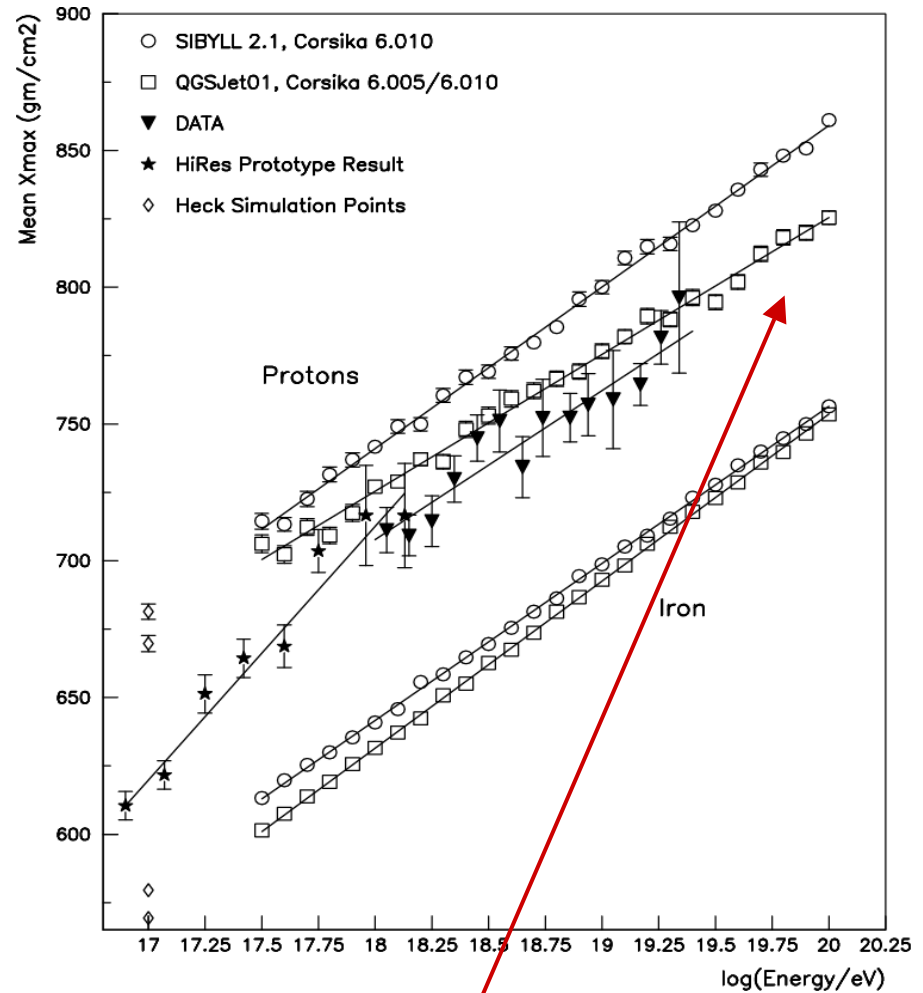
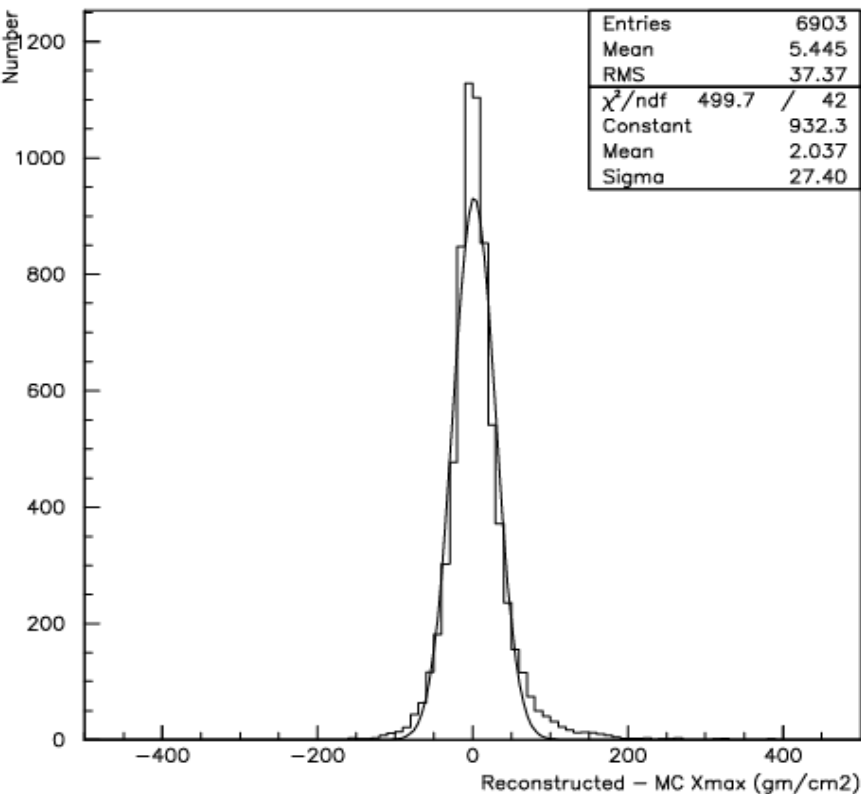

- **Higher statistics needed to extend analysis up to the GZK Threshold!**

Stereo Xmax Measurement

- Two simultaneous measurements of the Xmax allows for direct verification of the MC resolution

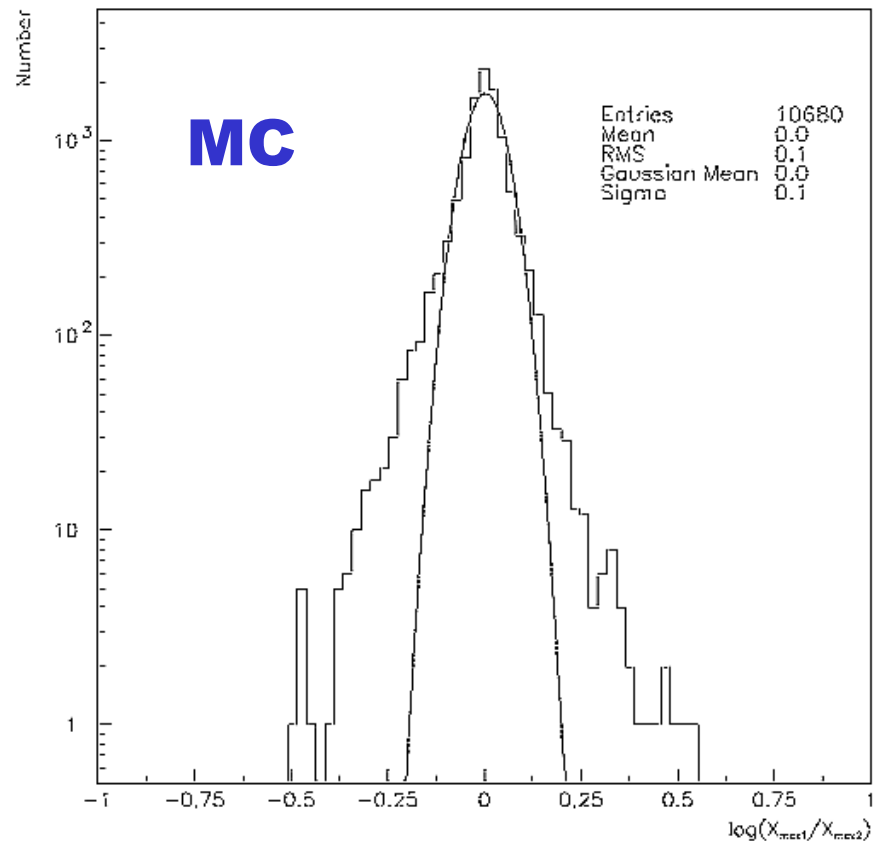
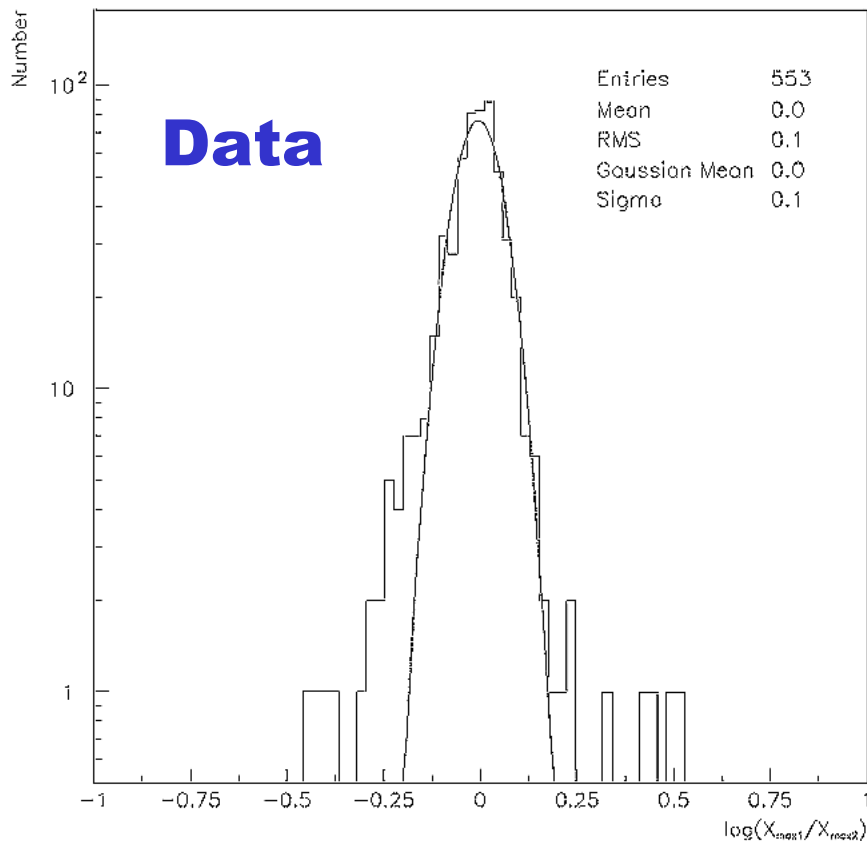

Systematic Uncertainty in Xmax

- Effect of pointing accuracy – 15 gm/cm²
- Effect of atmospheric variation – 10 gm/cm²
- Effect of using Std Atmosphere – 10 gm/cm²
- Reconstruction bias – 5 gm/cm²
- Sum in quadrature – 21.2 gm/cm²
- Will use 3-season-model in future work with composition

Nuclear & Particle Physics

- First HiRes measurement of *Inelastic proton-air cross-section* Paper in preparation (K. Belov)

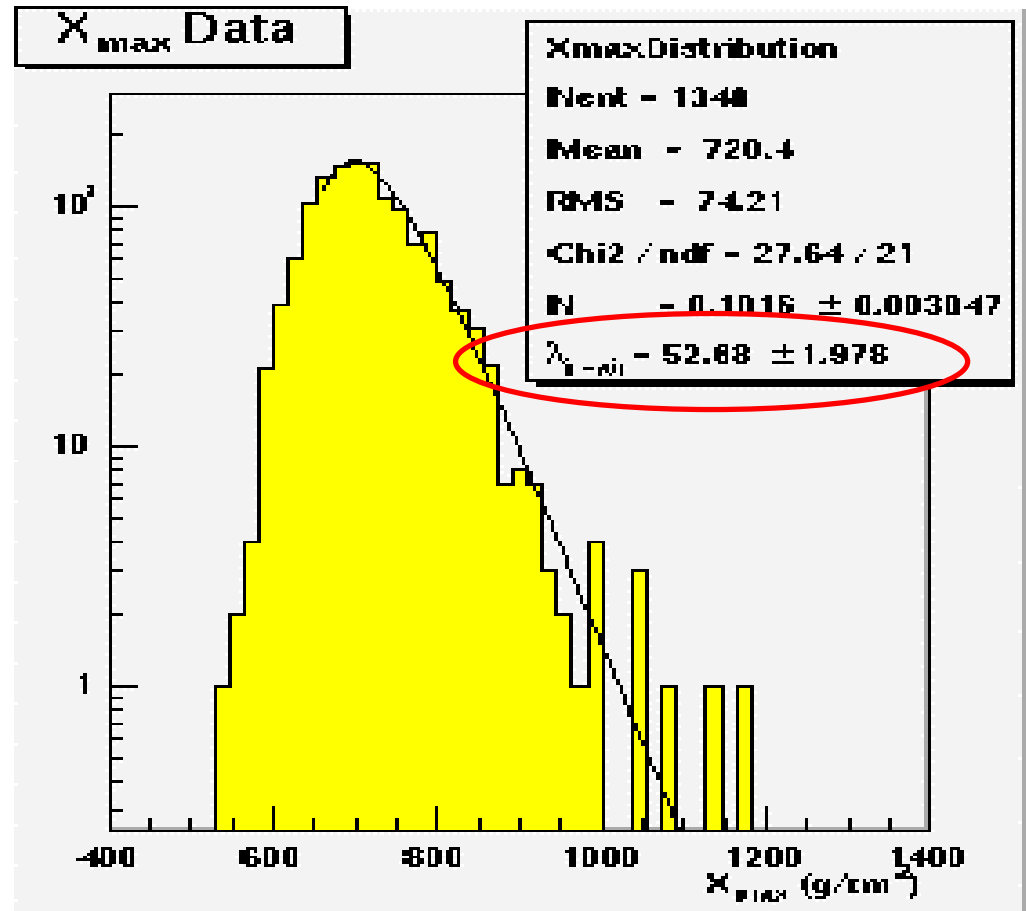
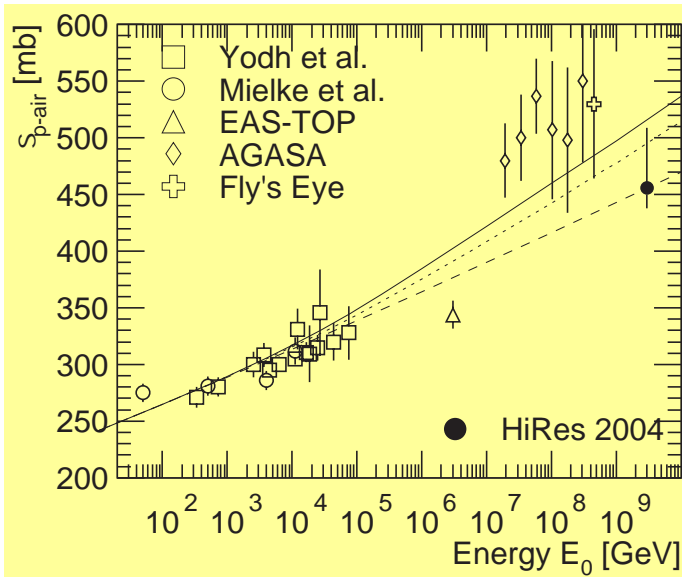
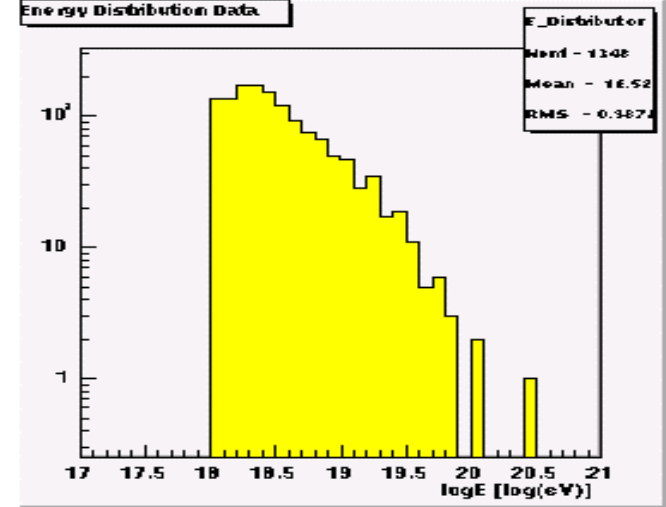

J. Hörandel QGSJET corrections using CDF (Abe et al. 1994), and E-710, E-810 (Amos et al., 1990, Avila et al., 1999).

X_{\max} and Energy Resolution— detector MC.

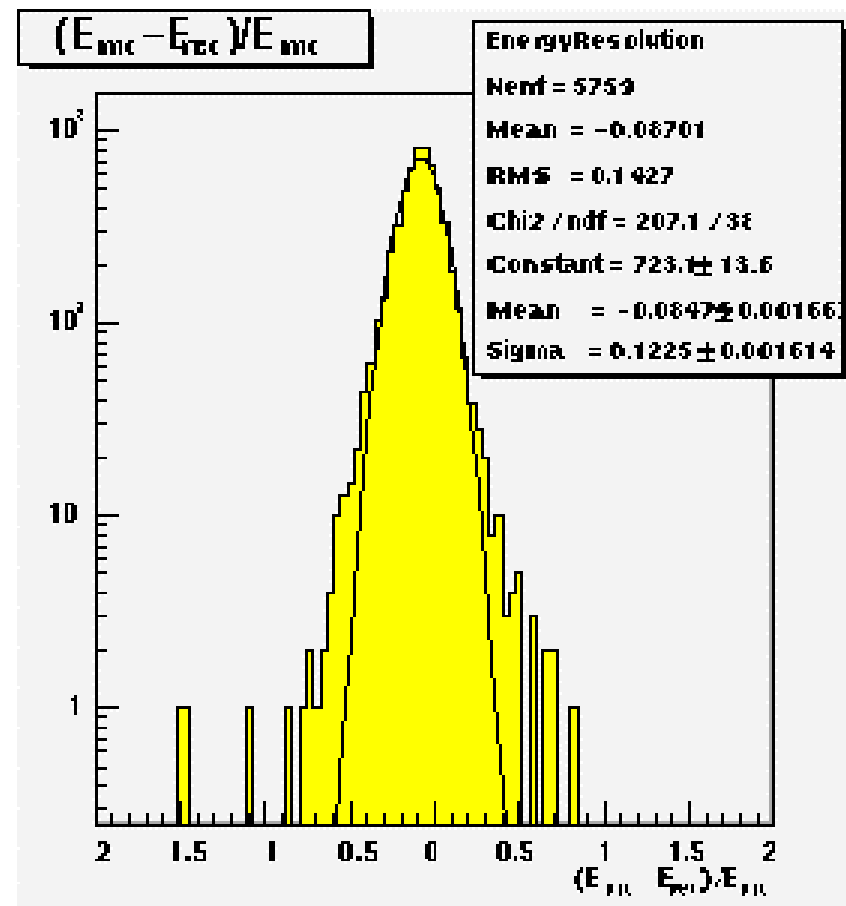
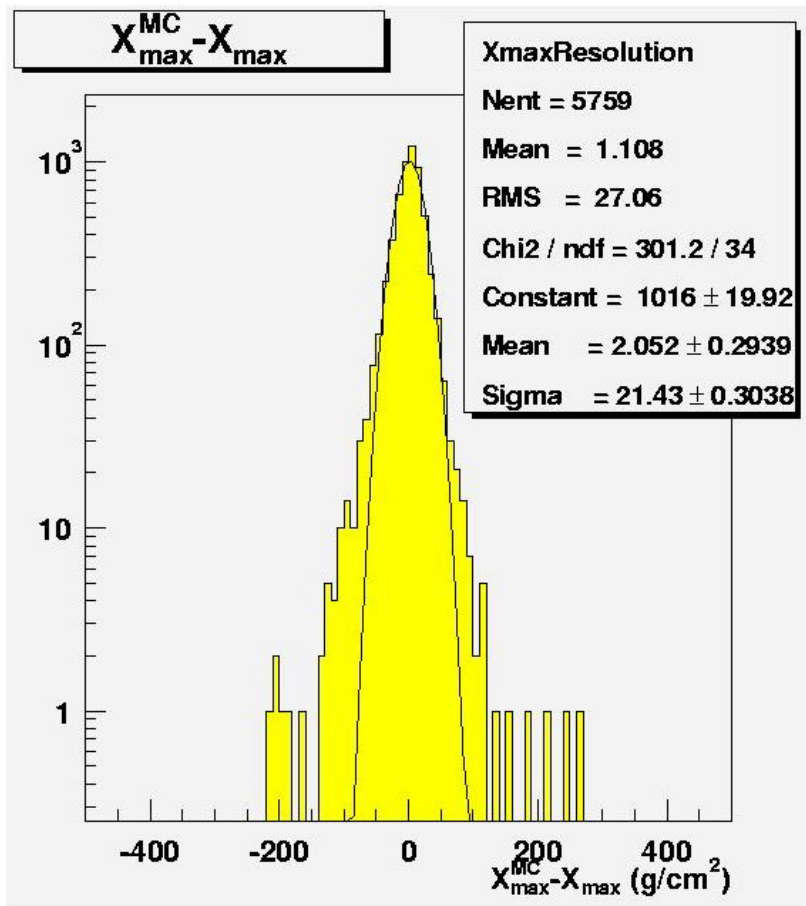

$$\Delta X_{\max} \approx 21 \text{ g} / \text{cm}^2$$

$$\Delta E = 12\%$$

Aspen
4/06/05 shift of $\langle X_{\max} \rangle \approx 2 \text{ g} / \text{cm}^2$

Composition influence – Fe & CNO.

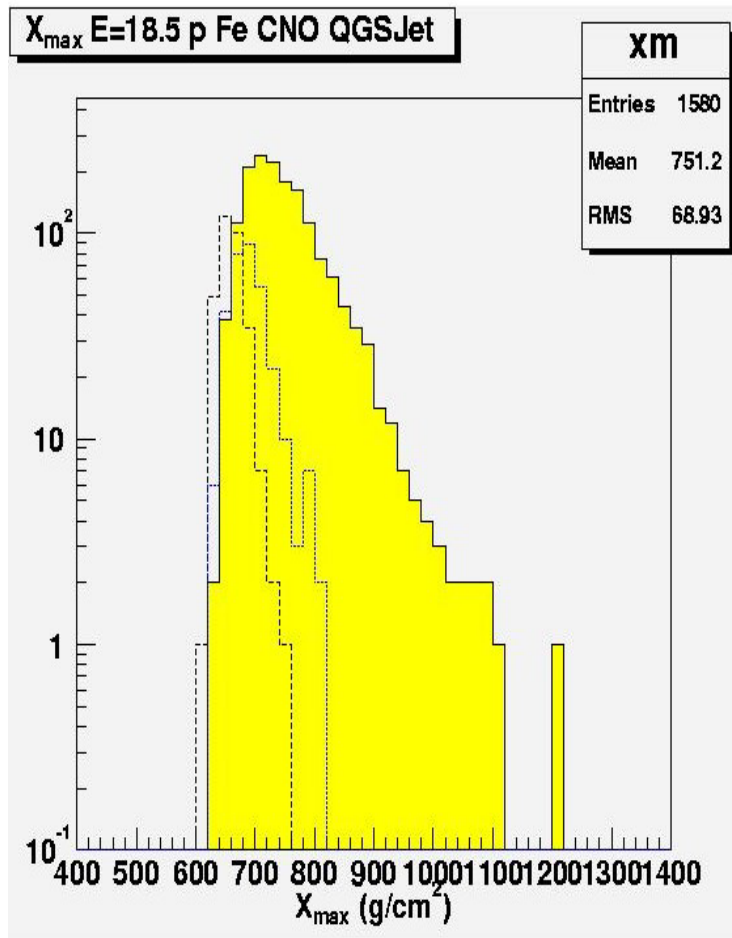

- 20% Fe is shown as dotted line.
- Heavier nuclei influence can be reduced by only using a part of the distribution deeper than 700 g/cm².

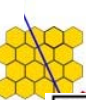

(P-Model) [mbar] vs height[km]

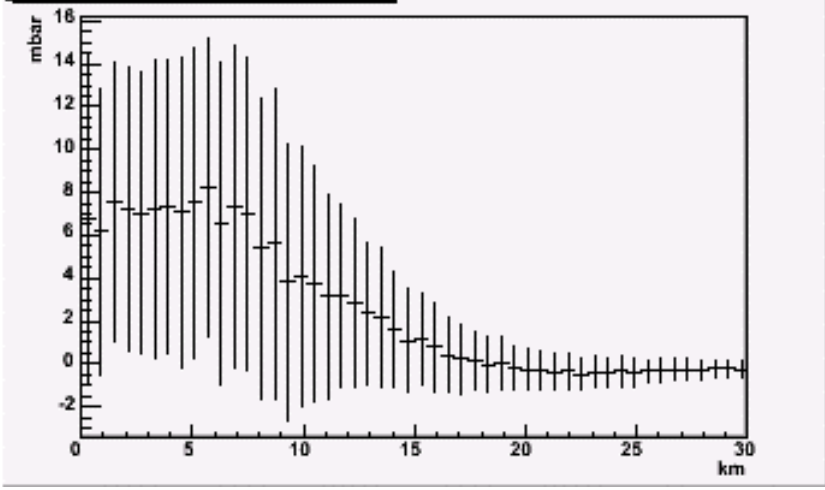

Utah (continued)

- The atmosphere over Utah appears much more stable and in good agreement with seasonal “Standard atmosphere” Models
- Residuals between measurements and model are typically less than ~10 mBar in the troposphere.

Temperature profile (summer)

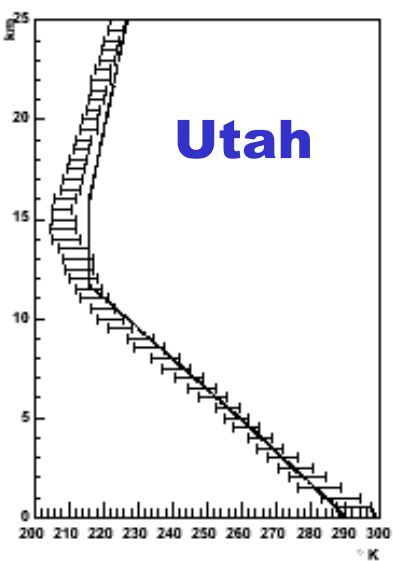

4/0 Summer

Temperature profile (winter)

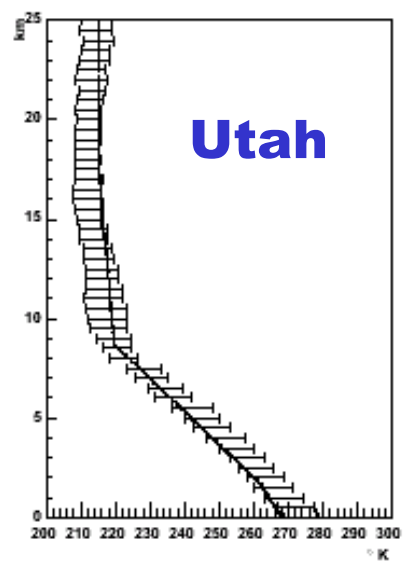

Winter

Temperature profile (spring)

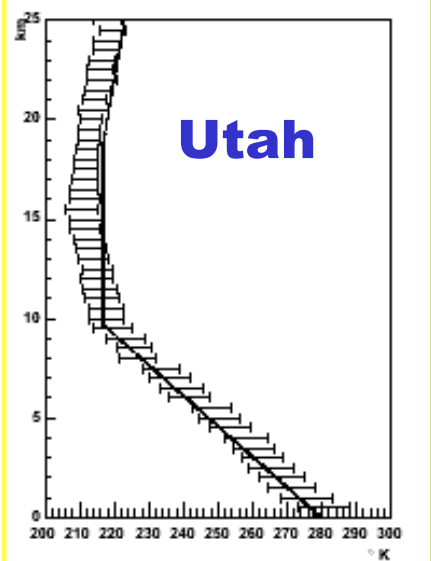

Spring

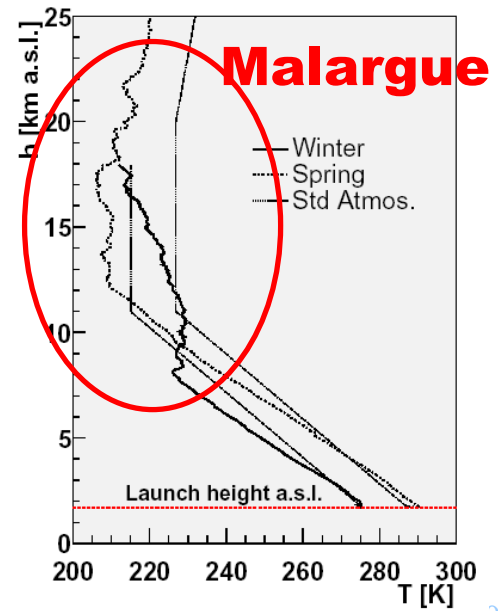

How much does the reconstructed shower X_{\max} shift using Radiosonde data (SLC) vs. using the US standard atmosphere model?

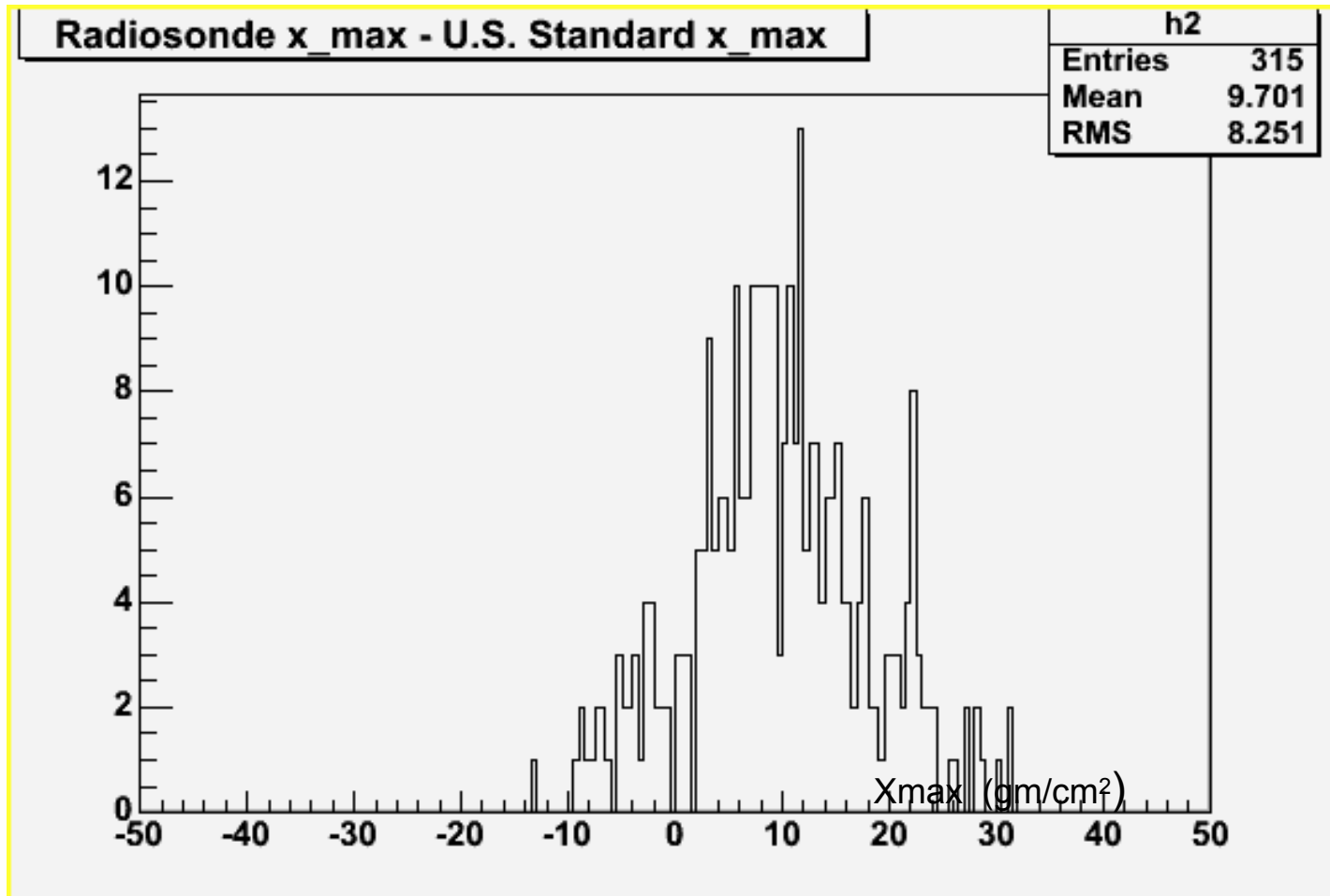

Summary

- HiRes has been operating in monocular mode since 1997 and stereo mode since late 2000
- Monocular spectrum is consistent with GZK suppression and shows a ankle near $\sim 4 \times 10^{18}$ eV
- In good agreement with FE stereo spectrum
- HiRes mono and stereo spectra are consistent
- Results in monocular and stereo anisotropy:
 - No point sources in HiRes data
 - Apparent overlap of one HiRes stereo event with AGASA triplet
 - Possible BL-Lac correlation
- X_{\max} composition result published
- P-air cross section